

CECW-EH-W  Engineer Manual 1110-2-3600	Department of the Army U.S. Army Corps of Engineers Washington, DC 20314-1000	EM 1110-2-3600  30 November 1987
	Engineering and Design  MANAGEMENT OF WATER CONTROL SYSTEMS	
	<b>Distribution Restriction Statement</b> Approved for public release; distribution is unlimited.	

CEEC-EH-W

Engineer Manual  
No. 1110-2-3600

30 November 1987

Engineering and Design  
MANAGEMENT OF WATER CONTROL  
SYSTEMS

1. Purpose. This manual provides guidance to field offices for the management of water control projects or systems authorized by Congress and constructed and operated by the Corps of Engineers. It also applies to certain water control projects constructed by other agencies or entities.

2. Applicability. This manual applies to all HQUSACE/OCE and field operating activities (FOA) having water control management responsibility for civil works projects.

3. Discussion. Management of projects or systems for water control requires special techniques to analyze and regulate water conditions to meet water management objectives. This manual covers project management related to the hydraulic and hydrologic aspects of completed projects which are more specifically known as water control management activities. These activities include: data collection and handling; determination of project inflow; scheduling of releases; coordination of water management decisions; and determination of releases. Regulation of water resource projects to meet water control objectives involves the operation of physical project features. In this regard, physical operation of structures is addressed only in terms of achieving the water control objectives. Non-hydraulic/hydrologic aspects of project operation and management are not addressed herein. The intent of this manual is to compile a comprehensive compendium of elements related to the management of water control systems including discussions of data collection and processing, water control analysis techniques, real-time management and systems analysis, and water quality, environmental and associated aspects of water management.

FOR THE COMMANDER:

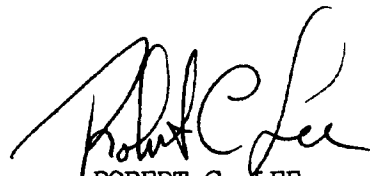

ROBERT C. LEE  
Brigadier General, USA  
Chief of Staff

Engineer Manual  
No. 1110-2-3600

30 November 1987

Engineering and Design  
MANAGEMENT OF WATER CONTROL SYSTEMS

## Table of Contents

Subject	Paragraph	Page
CHAPTER 1 INTRODUCTION		
Purpose . . . . .	1-1	1-1
Scope . . . . .	1-2	1-1
References. . . . .	1-3	1-5
CHAPTER 2 OBJECTIVES AND PRINCIPLES OF WATER CONTROL MANAGEMENT		
General Considerations. . . . .	2-1	2-1
Introduction . . . . .	2-1a	2-1
Water Management Goals and		
Objectives . . . . .	2-1b	2-1
Single Purpose Project Regulation. . . . .	2-1c	2-2
Multipurpose Project Regulation. . . . .	2-1d	2-2
System Control . . . . .	2-1e	2-3
Minimum Streamflow . . . . .	2-1f	2-3
Flood Control . . . . .	2-2	2-4
Historical Background. . . . .	2-2a	2-4
Flood Control Measures . . . . .	2-2b	2-5
Impoundments . . . . .	2-2c	2-5
Objectives for Reservoir Control		
of Floods. . . . .	2-2d	2-6
Reservoir Systems. . . . .	2-2e	2-6
Levees . . . . .	2-2f	2-7
Combined Impoundment and Levee		
Systems. . . . .	2-2g	2-8
Local Protection Projects. . . . .	2-2h	2-9
Navigation. . . . .	2-3	2-11
Historical Background. . . . .	2-3a	2-11
Water for Navigation . . . . .	2-3b	2-12
Water Releases for Navigation in		
Open Rivers. . . . .	2-3c	2-13
Winter Navigation. . . . .	2-3d	2-13

Subject	Paragraph	Page
Hydroelectric Power . . . . .	2-4	2-13
Historical Background. . . . .	2-4a	2-13
Hydropower Evaluation. . . . .	2-4b	2-14
Types of Projects. . . . .	2-4c	2-14
Integration and Control of Federal Hydropower Systems . . . . .	2-4d	2-14
Non-Federal Development of Hydropower at Corps of Engineers Projects . . . . .	2-4e	2-15
Water Supply. . . . .	2-5	2-16
Irrigation . . . . .	2-5a	2-16
Municipal and Industrial Water Supply Use. . . . .	2-5b	2-18
Water Quality . . . . .	2-6	2-19
Management Requirements. . . . .	2-6a	2-19
Objectives and Water Quality Standards. . . . .	2-6b	2-20
Monitoring Water Quality Conditions. . . . .	2-6c	2-20
Water Quality Releases for Downstream Control . . . . .	2-6d	2-21
Selective Withdrawal Facilities for Water Quality Control. . . . .	2-6e	2-21
Water Quality System Regulation. . . . .	2-6f	2-22
Fish and Wildlife. . . . .	2-7	2-23
Historical Background. . . . .	2-7a	2-23
General. . . . .	2-7b	2-23
Reservoir Fisheries. . . . .	2-7c	2-24
Tailwater Fisheries. . . . .	2-7d	2-26
Fish Migration . . . . .	2-7e	2-27
Minimum Releases . . . . .	2-7f	2-28
Reservoir Wildlife . . . . .	2-7g	2-28
Recreation. . . . .	2-8	2-29
Historical Background. . . . .	2-8a	2-29
General Requirements . . . . .	2-8b	2-29
Water Management Problems. . . . .	2-8c	2-30
Long-Term Seasonal Fluctuations of Reservoirs . . . . .	2-8d	2-30
Control of Streamflows for Downstream Recreational Use. . . . .	2-8e	2-30
Erosion and Deposition Considerations . . . . .	2-9	2-31
General. . . . .	2-9a	2-31
Downstream Considerations. . . . .	2-9b	2-31
Upstream Considerations . . . . .	2-9c	2-32
Guidelines . . . . .	2-9d	2-33
Aesthetic Considerations. . . . .	2-10	2-34

Subject	Paragraph	Page
<b>CHAPTER 3 DEVELOPMENT OF WATER CONTROL PLANS</b>		
Principles and Objectives . . . . .	3-1	3-1
Water Control Plans . . . . .	3-2	3-2
General. . . . .	3-2a	3-2
Integration of Water Quality into the Water Control Plan . . . . .	3-2b	3-3
Annual Water Management Plans. . . . .	3-2c	3-4
Input from Other Water Regulation Interests. . . . .	3-2d	3-4
Analysis of Drought Periods. . . . .	3-2e	3-5
Water Control Procedures During Planning and Design. . . . .	3-2f	3-6
Development of Regulation Schedules and Water Control Diagrams. . . . .	3-3	3-6
Definitions. . . . .	3-3a	3-6
Assessments of Changed Conditions from Planning and Design Studies . . . . .	3-3b	3-8
Basic Flood Control Regulation . . . . .	3-3c	3-10
Integration of Basic Seasonal Flood Control Guide Curves with Other Objectives . . . . .	3-3d	3-16
Testing Water Control Plans . . . . .	3-4	3-20
General. . . . .	3-4a	3-20
Short-Term Flood Control Analysis. . . . .	3-4b	3-20
Long-Term Water Utilization Analysis . . . . .	3-4c	3-20
Winter Navigation . . . . .	3-5	3-21
Revision of Water Control Plans . . . . .	3-6	3-21
General. . . . .	3-6a	3-21
Additional or New Hydrologic Data. . . . .	3-6b	3-22
Reevaluation of Water Control Requirements and Objectives. . . . .	3-6c	3-22
Updating or Modifying Water Quality Control Procedures and Plans . . . . .	3-6d	3-23
Constraints on Water Control Plans . . . . .	3-6e	3-24
<b>CHAPTER 4 OPERATIONAL CHARACTERISTICS OF WATER CONTROL FACILITIES</b>		
General Considerations. . . . .	4-1	4-1
Background Information . . . . .	4-1a	4-1
Types of Facilities. . . . .	4-1b	4-1
Design Criteria. . . . .	4-1c	4-1
Terminology. . . . .	4-1d	4-2

Subject	Paragraph	Page
Spillways . . . . .	4-2	4-2
General. . . . .	4-2a	4-2
Energy Dissipators . . . . .	4-2b	4-3
Spillway Gates . . . . .	4-2c	4-4
Spillway Capacity and Discharge Ratings. . . . .	4-2d	4-5
Operation of Spillway Gates. . . . .	4-2e	4-6
Outlet Works. . . . .	4-3	4-6
Functional Requirements. . . . .	4-3a	4-6
Sluices for Concrete Dams. . . . .	4-3b	4-7
Gate Passageways . . . . .	4-3c	4-7
Control Works. . . . .	4-3d	4-7
Operation of the Control Works . . . . .	4-3e	4-8
Discharges . . . . .	4-3f	4-8
Outlet Facilities for Embankment Dams . . . . .	4-3g	4-8
Low-Flow Facilities. . . . .	4-3h	4-9
Selective Withdrawal Systems . . . . .	4-3i	4-9
Energy Dissipation . . . . .	4-3j	4-10
Summary. . . . .	4-3k	4-10
Flood Control Operation . . . . .	4-4	4-10
Project Outflows . . . . .	4-4a	4-10
Controlling and Monitoring Outlet and Spillway Gate Regulation . . . . .	4-4b	4-11
Combined Use of Outlet Works and Spillways. . . . .	4-4c	4-11
Free-Flow Operation of Gated Spillways which Control Large Natural Lakes. . . . .	4-4d	4-12
Induced Surcharge Storage . . . . .	4-5	4-13
General Principles. . . . .	4-5a	4-13
Surcharge Storage for Free-Flow Ungated Spillways . . . . .	4-5b	4-13
Development of Induced Surcharge Envelope Curves. . . . .	4-5c	4-14
Development of Spillway Gate Regulation Schedules . . . . .	4-5d	4-17
Testing Spillway Regulation Schedule	4-5e	4-19
Methods of Operation . . . . .	4-5f	4-19
Effect on Spillway Gate Design . . . . .	4-5g	4-22
Outlet Works for Water Supply . . . . .	4-6	4-22
General Considerations . . . . .	4-6a	4-22
Special Requirements and Problems. . . . .	4-6b	4-23

Subject	Paragraph	Page
Diversion and Bypass Structures . . . . .	4-7	4-23
Project Purposes and Types . . . . .	4-7a	4-23
Regulation Procedures and Schedules . . . . .	4-7b	4-24
Hurricane or Tidal Barriers . . . . .	4-8	4-24
Interior Flood Control Facilities . . . . .	4-9	4-24
General . . . . .	4-9a	4-24
Operational Criteria . . . . .	4-9b	4-25
Legal Requirements . . . . .	4-9c	4-25
Hydroelectric Power Facilities . . . . .	4-10	4-25
General . . . . .	4-10a	4-25
Engineering Manual on Hydropower (EM 1110-2-1701) . . . . .	4-10b	4-26
Major Hydroelectric Facilities . . . . .	4-10c	4-26
Plant and Unit Control Systems . . . . .	4-10d	4-26
Plant and Unit Operation . . . . .	4-10e	4-27
Integration into Regional Power System . . . . .	4-10f	4-27
Control Equipment . . . . .	4-10g	4-28
Special Operating Problems . . . . .	4-10h	4-28
Fish Passage Facilities and Use of Water Control Facilities For Fishery Enhancement . . . . .	4-11	4-33
General Considerations . . . . .	4-11a	4-33
Fish Passage Facilities . . . . .	4-11b	4-34
Fish Attraction Water . . . . .	4-11c	4-34
Fingerling Fish Bypass Facilities . . . . .	4-11d	4-35
Increased Streamflows to Aid Passage of Downstream Migrants . . . . .	4-11e	4-35
Fish Hatcheries . . . . .	4-11f	4-36
Control of Dissolved Gas Supersaturation . . . . .	4-11g	4-36
Coordination of Regulation for Fishery . . . . .	4-11h	4-37
 CHAPTER 5 WATER CONTROL DATA SYSTEMS		
General . . . . .	5-1	5-1
Purpose . . . . .	5-1a	5-1
Basic Requirements . . . . .	5-1b	5-1
Master Plans . . . . .	5-1c	5-2
Data Observation and Storage at Field Sites . . . . .	5-2	5-3
General . . . . .	5-2a	5-3
Hydrometeorological Data . . . . .	5-2b	5-3
Project Data . . . . .	5-2c	5-4
Water Quality Data . . . . .	5-2d	5-5

Subject	Paragraph	Page
Manual Data Observation. . . . .	5-2e	5-5
Automated Data Observation and Storage. . . . .	5-2f	5-6
Installation and Maintenance of Data Collection Equipment . . . . .	5-2g	5-6
Data Transmission . . . . .	5-3	5-7
General. . . . .	5-3a	5-7
Manual Data Transmission Systems . .	5-3b	5-8
Semi-Automatic Data Transmission Systems. . . . .	5-3c	5-8
Automatic Data Transmission Systems.	5-3d	5-9
Decoding and Validating Transmitted Data. . . . .	5-4	5-14
Water Control Data Management . . . . .		
and Processing. . . . .	5-5	5-15
Data Storage and Retrieval . . . . .	5-5a	5-15
Water Control Database Management. .	5-5b	5-15
Data Interpretation and Displays . .	5-5c	5-15
Data Processing. . . . .	5-5d	5-15
Coordination of Data Collection and Exchange. . . . .	5-6	5-16
Interagency Cooperation. . . . .	5-6a	5-16
Operational Management of Cooperative Data Systems . . . . .	5-6b	5-19
Data Exchange. . . . .	5-6c	5-19
 CHAPTER 6 WATER CONTROL ANALYSIS TECHNIQUES		
General Considerations. . . . .	6-1	6-1
Importance of Technical Evaluations.	6-1a	6-1
Hydrologic Analysis - Historical Data . . . . .	6-1b	6-1
Computer Utilization for Water Management. . . . .	6-2	6-2
Basic Principles . . . . .	6-2a	6-2
Concepts in Computer Utilization . .	6-2b	6-3
Types of Models. . . . .	6-2c	6-3
Meteorological Forecasts Used in Water Control Management. . . . .	6-3	6-4
General. . . . .	6-3a	6-4
Short-Term Weather Forecasts . . . .	6-3b	6-5
Long-Range Weather Forecasts . . . .	6-3c	6-8
Simplified Manual Methods for Analyzing River Response. . . . .	6-4	6-8
Backup Procedures. . . . .	6-4a	6-8
Graphical Runoff Relationships . . .	6-4b	6-8



Subject	Paragraph	Page
Long-Range Predictions of Streamflow. . .	6-5	6-9
General. . . . .	6-5a	6-9
Statistical Procedures for Forecasting Seasonal Snowmelt Runoff Volume. . . . .	6-5b	6-10
Use of Deterministic Hydrologic Models for Long-Term Streamflow Forecasts. . . . .	6-5c	6-11
Long-Range Analysis of Project Regulation. . . . .	6-6	6-12
General. . . . .	6-6a	6-12
Analytical Techniques. . . . .	6-6b	6-12
Basic Data and Types of Analyses . .	6-6c	6-12
Utilizing Results of Long-Range Analysis . . . . .	6-6d	6-13
Water Quality Forecasting . . . . .	6-7	6-14
General. . . . .	6-7a	6-14
Analytical Techniques. . . . .	6-7b	6-14
Forecasts. . . . .	6-7c	6-14
Special Hydrologic Analyses . . . . .	6-8	6-15
General. . . . .	6-8a	6-15
Unsteady Flow Determinations in Major Rivers . . . . .	6-8b	6-16
Effects of Sedimentation in Rivers and Reservoirs . . . . .	6-8c	6-16
Effects of Ice in Rivers and Reservoirs . . . . .	6-8d	6-17
Reservoir Evaporation. . . . .	6-8e	6-18
Determination of Effect of Bank Storage on Reservoir Capacity. . .	6-8f	6-18
Effect of Wind Setup on Water Levels in Reservoirs, Lakes, and Tidal Estuaries. . . . .	6-8g	6-18
CHAPTER 7 REAL TIME MANAGEMENT OF WATER CONTROL PROJECTS		
Basic Considerations. . . . .	7-1	7-1
Integration of Generalized Operating Criteria, Real-Time System Analysis, and Project Scheduling . . . . .	7-1a	7-1
Input from Others. . . . .	7-1b	7-2
Appraisal of Current Project Regulation. . . . .	7-2	7-3

Subject	Paragraph	Page
Performing System Analyses for Project Scheduling. . . . .	7-3	7-3
Analytical Requirements for Scheduling Water Regulation at Projects . . . . .	7-3a	7-3
Preparing Model Input Data . . . . .	7-3b	7-4
Analysis of Results. . . . .	7-3c	7-5
Water Control Decisions and Project Scheduling. . . . .	7-4	7-5
Need for Judgmental Determinations in Project Scheduling. . . . .	7-4a	7-5
Coordinating Water Control Decisions with Others. . . . .	7-4b	7-6
Project Schedules and Operating Instructions . . . . .	7-4c	7-7
Water Quality Aspects of Water Control Decisions . . . . .	7-4d	7-8
Disseminating Regulation Schedules. . . . .	7-5	7-8
Corps of Engineers Projects. . . . .	7-5a	7-8
Non-Corps Projects . . . . .	7-5b	7-9
Distributing Schedules to Other Agencies . . . . .	7-5c	7-9
Distributing Schedules to General Public . . . . .	7-5d	7-9
Water Management Activities During Flood Events . . . . .	7-6	7-9
Importance of Water Management Activities . . . . .	7-6a	7-9
Coordination of Corps Activities . . . . .	7-6b	7-10
Monitoring and Reanalyzing River and Reservoir Conditions During Floods. . . . .	7-6c	7-12
Adjusting Reservoir Regulation Schedules. . . . .	7-6d	7-12
Drought Management Plans. . . . .	7-7	7-12
Coordinating Forecasts of Streamflow and River Levels. . . . .	7-8	7-13
General. . . . .	7-8a	7-13
Basin-Wide Forecasting Services. . . . .	7-8b	7-14

Subject	Paragraph	Page
CHAPTER 8 ADMINISTRATIVE AND COORDINATION REQUIREMENTS FOR WATER CONTROL MANAGEMENT		
Administration of Water Control		
Management Activities . . . . .	8-1	8-1
Organization . . . . .	8-1a	8-1
Functions. . . . .	8-1b	8-1
Staffing . . . . .	8-1c	8-2
Role of Project Operators. . . . .	8-1d	8-2
Training . . . . .	8-1e	8-3
Briefing Room Facilities. . . . .	8-2	8-4
General. . . . .	8-2a	8-4
Purpose. . . . .	8-2b	8-4
Design . . . . .	8-2c	8-4
Utilization. . . . .	8-2d	8-6
Administration of Water Management		
Contracts . . . . .	8-3	8-7
Data Collection. . . . .	8-3a	8-7
Water Supply Contracts . . . . .	8-3b	8-8
Water Quality Data Collection. . . . .	8-3c	8-8
Hydropower Contracts . . . . .	8-3d	8-8
Interagency Coordination and Agreements	8-4	8-8
Types of Coordinating Groups . . . . .	8-4a	8-8
Types of Water Management Agreements	8-4b	8-10
Coordinating with Operating Entities and Other Public and Private Water Use Organizations. . . . .	8-4c	8-11
Water Management Reports on Prevailing Conditions. . . . .		
General. . . . .	8-5	8-15
Project Operators Reports . . . . .	8-5a	8-15
Water Control Morning Reports. . . . .	8-5b	8-16
Special Advisories . . . . .	8-5c	8-16
Discharge Data . . . . .	8-5d	8-16
Flood Damages. . . . .	8-5e	8-17
Reports for the Media. . . . .	8-5f	8-17
Documents, Reports and Records. . . . .	8-5g	8-17
Water Control Documents. . . . .	8-6	8-17
Annual Operating Plans and Other River Basin Committee Reports. . . . .	8-6a	8-17
Annual Report on Water Control Management Activities. . . . .	8-6b	8-17
Reports on the Water Control Data System (WCDS) Master Plan. . . . .	8-6c	8-18
Annual Report on the Cooperative Stream Gaging Program. . . . .	8-6d	8-18
	8-6e	8-18

Subject	Paragraph	Page
Annual Billing for the Cooperative Reporting Network . . . . .	8-6f	8-18
Annual Budget Request . . . . .	8-6g	8-18
Summary of Runoff Potential . . . . .	8-6h	8-19
Post Flood Reports . . . . .	8-6i	8-19
Water Data Records . . . . .	8-6j	8-19
Federal Register . . . . .	8-6k	8-19
Annual Report on Project Benefits . . . . .	8-6l	8-20
Annual Water Quality Report . . . . .	8-6m	8-20
Periodic Inspections and Reports . . . . .	8-6n	8-21
 CHAPTER 9 PREPARATION OF WATER CONTROL DOCUMENTS		
Basic Documents . . . . .	9-1	9-1
Types of Documents . . . . .	9-1a	9-1
Types of Projects . . . . .	9-1b	9-1
Scope of Documentation . . . . .	9-1c	9-2
Standing Instructions to Project Operators for Water Control . . . . .	9-2	9-2
Water Control Plans . . . . .	9-3	9-3
General . . . . .	9-3a	9-3
Interim Water Control Plan During Construction . . . . .	9-3b	9-3
Preliminary Water Control Plans . . . . .	9-3c	9-4
Final Water Control Plans . . . . .	9-3d	9-4
Water Control Manuals . . . . .	9-4	9-5
Water Control Manuals for Individual Projects . . . . .	9-4a	9-5
Master Water Control Manuals . . . . .	9-4b	9-6
Initial Reservoir Filling Plans and Flood Emergency Plans . . . . .	9-4c	9-6
Format of Water Control Documents . . . . .	9-5	9-9
General . . . . .	9-5a	9-9
Tables, Graphs, and Plates . . . . .	9-5b	9-9
Use of the Terms "Regulation" and "Operation" . . . . .	9-5c	9-9
Document Identity . . . . .	9-5d	9-9
Coordination of Water Control Documents . . . . .	9-6	9-9
General . . . . .	9-6a	9-9
Coordination . . . . .	9-6b	9-9
Water Management Agreements . . . . .	9-6c	9-10
Exhibits . . . . .		9-11
A. Format for Standing Instructions to the Project Operator for Water Control . . . . .		9-11
B. Format for Water Control Plan . . . . .		9-15

Subject	Paragraph	Page
<hr/>		
APPENDIX A	BIBLIOGRAPHY	
	Preface . . . . .	A-1
	Specific References . . . . .	A-2
	General References . . . . .	A-4
APPENDIX B	INDEX	



Figure i-1. Dale Hollow Dam, Obey River, Tennessee;  
Nashville District

## CHAPTER 1

### INTRODUCTION

1-1. Purpose. This manual is intended to provide guidance to field offices for the management of water control projects or systems that have been authorized by Congress and planned, designed and constructed by the Corps of Engineers. It also applies to certain aspects of water control projects constructed by other agencies or entities. Technical procedures used in the planning and design of Corps of Engineers projects are well documented in regulations and manuals, and they are done in accordance with established authority. Management of these systems for water control, however, requires special techniques beyond those used in the planning, design and construction phases, to analyze and regulate water conditions at individual projects in order to meet water management objectives.

#### 1-2. Scope

a. General. This manual covers project management related to the hydrologic/hydraulic aspects of completed projects, which are more specifically known as "water control management" activities. These activities include: data collection and handling; determination of project inflow, scheduling releases for flood control, hydropower, water supply, water quality, fish and wildlife; coordination of water management decisions; and determination of releases; i.e., water resource projects are "regulated" to meet water control objectives by "operating" spillway gates, sluice gates, pumping plants, etc. In this regard, the "physical operation" of structures, such as the manipulation of gates or recognition of structural constraints, is addressed only in terms of achieving the water control objectives. The term "operation" is used interchangeably throughout the manual to mean "regulation for water control" such as project release scheduling as well as to mean the "physical operation" of projects. In the same regard, the phrase "project operator" is used interchangeably with "project manager" to refer to the person at the project site who is responsible for the physical operation of the project. Non-hydrologic/hydraulic aspects of project operation and maintenance are not addressed herein. It is the intent of this manual to compile a comprehensive compendium of elements related to the management of water control systems, including discussions of:

(1) fundamentals of multipurpose water control projects and system regulation;

(2) techniques of preparing water control plans including regulation schedules, for a single project or system, for meeting all multipurpose objectives in accordance with project planning and design, and other objectives as necessary;

(3) methods for collecting, processing and disseminating basic data required for real-time management of water control projects and systems;

(4) methods for analyzing river and reservoir systems on a real-time basis to determine the most suitable regulation of projects, including utilization of automatic data processing techniques for simulating the response of hydrologic systems;

(5) problems and solutions related to environmental, social, economic and aesthetic aspects of water management;

(6) methods for making and implementing real-time water control decisions;

(7) administrative and coordination requirements by the Corps of Engineers for developing water control plans and manuals for an individual project or system, organizing water management activities in Division and District offices, and reporting current conditions of water control systems to higher authority; and

(8) methods for coordinating water management activities with others, on a local, regional and national basis, and providing information to the public regarding the current management of water control systems.

b. Chapter 2. Chapter 2 is a generalized description of the objectives and principles for the management of water for various multipurpose uses, including:

- Flood Control
- Navigation
- Hydropower
- Water Supply
- Water Quality



- Recreation
- Fish and Wildlife

The specific requirements for any one of the above-listed elements (functional, economic, environmental, social and aesthetic) are unique to a given river basin, and it is not intended to present detailed solutions. The manual describes each element, insofar as the principles apply to projects generally, and the necessity for considering all elements as well as the safety and integrity of the project.

c. Chapter 3. This Chapter covers the technical aspects of developing water control plans, which often encompass multipurpose and multiproject systems. Even in the case of a single purpose project, there are often important social and/or environmental aspects to be accounted for in the overall management of a river system. The manual provides guidelines for the formulation of detailed regulation criteria, which are based largely on planning and design studies, together with the use of techniques for water management to attain the overall goals. Preparation of water control diagrams, which include the regulating criteria in the form of guide curves and release schedules, are discussed. There is also a section which deals with requirements contained in water control agreements for non-Corps projects, as set forth in the revision of 33 CFR 208.11, published in the Federal Register, Vol. 43, No. 199, October 13, 1978.

d. Chapter 4. This chapter contains a brief description of the design of hydraulic facilities at water control projects. These include spillways, spillway gates, regulating outlets, bypass and diversion structures, interior drainage facilities, navigation locks, hydropower facilities, fish passage facilities, and special devices for regulating the quality of water released from a reservoir. Special emphasis is placed on the methods for controlling floods through the combined use of spillway gates and/or regulating outlets in order to utilize surcharge storage in reservoirs. Also mentioned are special water control management problems involved in the utilization of bypass structures, hydropower facilities, navigation locks, and fish passage facilities.

e. Chapter 5. This chapter summarizes the methods available for collecting, processing, storing and disseminating basic data for project regulation. These data systems may include any or all of the following:

- manual observations
- land line or radio communication systems for automatic retrieval of remote data
- satellite communication and sensing devices
- meteor-burst communication devices
- various types of sensors, processors, and relay devices necessary for obtaining and relaying remote hydrometeorologic and project data
- centralized automatic data processing facilities required for accessing and controlling the flow of data

This chapter also presents methods for coordinating data collection with other organizations, and the use of cooperatively developed data systems.

f. Chapter 6. Chapter 6 of the manual contains methods of hydrologic analysis which are directly applicable to management of water control systems. These include generalized computer techniques to simulate the continuous natural response of hydrologic and river systems, combined with the effects of project regulation on conditions of streamflow and river stages. These simulations are used to evaluate the effects of alternative conditions or assumptions in forecasting streamflows and project regulation. There is a description of meteorological assessments and forecasts that are important to project regulation. Systems analysis techniques also include methods for analyzing and projecting long-term regulation of projects for several months to a year in advance. These projections are based on known or assumed conditions of stream and operating criteria. These analyses are useful in evaluating alternatives in system regulation and adjusting the water control plan for flood control, hydropower, irrigation, navigation, water quality, fishery requirements, or other project purpose as may be required to assess the particular observed and projected conditions of hydrology and project regulation on the overall management of the water. Other aspects of hydrologic analysis include reservoir evaporation, effect of ice and wind, streamflow determination, hurricanes, tsunami waves, tidal effects, artificial flood waves, ground water effects, effects of changing channel capacities downstream from projects, and the effect of forest removal and urban development on runoff.

g. Chapter 7. This chapter presents the methods for integrating system guidelines for water control management, criteria and goals for scheduling water releases. The specific schedules are developed utilizing all existing current information, hydrometeorological data, project data, and projections developed by simulation techniques. There is a discussion of organization and staffing required to perform this function, methods of arriving at daily water control decisions, and how water control decisions may be disseminated and implemented at the project level. Also, methods for coordinating water releases, streamflow and regulation forecasts with other interests are discussed. There is a description of requirements of regulation during floods or other emergency conditions, as opposed to normal routine regulation, and methods for disseminating vital information to the news media and the general public.

h. Chapter 8. Chapter 8 deals with the administrative and coordination requirements of the Corps in managing water control systems. There are discussions of the role of the Corps in the regulation of international rivers and the authority for regulating projects constructed by other entities in the United States. The content of this chapter is derived primarily from existing Engineering Regulations (ER's) in summarizing the requirements for administrative control by the Corps.

i. Chapter 9. This chapter discusses the preparation of water control documents. These documents include standing instruction to project operators, water control plans and manuals.

### 1-3. References

a. Engineer Regulations and Manuals. The following regulations, manuals, and other publications define policy and basic methods directly related to water management activities by the Corps of Engineers.

- (1) ER 15-2-13, Mississippi Water Control Management Board
- (2) ER 15-2-14, Committees on Tidal Hydraulics, Channel Stabilization and Water Quality
- (3) ER 500-1-1, Natural Disaster Procedures
- (4) ER 1105-2-20, Project Purpose Planning Guidance

- (5) ER 1110-2-50, Low Level Discharge Facilities for Draw-Down of Impoundments
- (6) ER 1110-2-240, Water Control Management
- (7) ER 1110-2-241, Use of Storage Allocated for Flood Control and Navigation at Non-Corps Projects
- (8) ER 1110-2-248, Requirements for Water Data Transmission using GOES/DCS
- (9) ER 1110-2-249, Management of Water Control Data Systems
- (10) ER 1110-2-1150, Engineering after Feasibility Studies
- (11) ER 1110-2-1400, Reservoir Control Centers
- (12) ER 1110-2-1402, Hydrologic Investigations Requirements for Water Quality Control
- (13) ER 1110-2-1454, Corps Responsibility for Non-Federal Hydroelectric Power Development under the Federal Power Act
- (14) ER 1110-2-1455, Cooperative Stream Gaging Program
- (15) ER 1110-2-2901, Construction Cofferdams
- (16) ER 1110-2-1941, Drought Contingency Plans
- (17) ER 1125-2-308, Radio Frequency and Call Sign Assignments
- (18) ER 1130-2-334, Reporting Water Quality Management Activities at Corps Civil Works Projects
- (19) ER 1130-2-415, Water Quality Data Collection Interpretation and Application Activities
- (20) ER 1130-2-419, Dam Operations Management Policy
- (21) 33 CFR 208.11 (ER 1110-2-241) (Revised), Part 208, Flood Control Regulation, Use of Storage Allocated for Flood Control and Navigation Purposes, Published in Federal Register., Vol. 43, No. 1999, October 13, 1978
- (22) EM 1110-2-1201, Reservoir Water Quality Analysis

- (23) EM 1110-2-1405, Flood Hydrograph Analysis and Computation
- (24) EM 1110-2-1406, Runoff from Snowmelt
- (25) EM 1110-2-1408, Routing of Floods through River Channels
- (26) EM 1110-2-1412, Storm Surge Analysis
- (27) EM 1110-2-1413, Hydrologic Analysis of Interior Areas
- (28) EM 1110-2-1602, Hydraulic Design of Outlet Works
- (29) EM 1110-2-1603, Hydraulic Design of Spillways
- (30) EM 1110-2-1604, Hydraulic Design of Navigation Locks
- (31) EM 1110-2-1611, Layout and Design of Shallow-Draft Waterways
- (32) EM 1110-2-1701, Hydropower
- (33) ETL 1110-2-231, Initial Reservoir Filling Plan
- (34) ETL 1110-2-251, Preparation of Water Control Manuals

b. Other Technical Publications. Appendix A consists of a selected bibliography of literature pertaining to management of water control systems.



Figure 1-1. Foster Joseph Sayers Dam, Bald Eagle Creek,  
Pennsylvania; Baltimore District

## CHAPTER 2

### OBJECTIVES AND PRINCIPLES OF WATER CONTROL MANAGEMENT

#### 2-1. General Considerations

##### a. Introduction

(1) This chapter provides a summary of water control management objectives and principles for various types of water control systems. It presents a brief synopsis of the technical aspects of each of the specific water control requirements to achieve the water management goals set forth below. The discussions present only broad aspects of each water regulation function, and their interrelationship needed for developing a water control plan.

(2) The sections that follow in this chapter discuss the individual functional objectives and principles in water management to achieve flood control, navigation, hydroelectric power, water supply (irrigation, municipal and industrial), water quality, and the preservation or enhancement of fish and wildlife, and recreational use. The discussions provide background information for more detailed presentations in subsequent chapters on methods of developing water control plans and scheduling water releases.

b. Water Management Goals and Objectives. The policy contained in Paragraph 6 of ER 1110-2-240 defines the goals and objectives for water regulation by the Corps. In summary, the objective is to conform with specific provisions of project-authorizing legislation and water management criteria defined in Corps of Engineers reports prepared in the planning and design of a particular project or system. Beyond this, the goals for water management will include provisions as set forth in any applicable authorities established after project construction and all applicable Congressional Acts relating to operations of Federal facilities (for example, the Fish and Wildlife Coordination Act, PL 85-624; Federal Water Project Regulation Act - Uniform Policies, PL 85-624; National Environmental Policy Act of 1969, PL 91-190; and Clean Water Act of 1977, PL 95-217). A general prime requirement in project regulation is the safety of users of the facilities and the general public, both at projects and downstream locations. The development of water control plans and the scheduling of releases at projects will be coordinated with appropriate agencies or entities (international, Federal, state or local), as necessary to meet commitments made in planning or design. Another goal in water management is to adjust water control plans, whenever possible, to account for changing local conditions.

c. Single Purpose Project Regulation

(1) General. In some cases, reservoirs are authorized for a single purpose and their operation must be for attainment of the authorized purpose. However, the method of operation can often be flexible and this flexibility can produce significant benefits over and above the authorized objective. The operation must be tuned to produce the benefits for environmental and social goals such as flood control, instream quality, in-lake quality, recreation, power, or any other attainable goals the project can achieve without compromising the authorized project purpose.

(2) Reservoirs with Uncontrolled Outlet Works

(a) Some reservoirs have been constructed with uncontrolled outlets. Outflow is dependent on conditions of natural inflow, and storage. With no provision for regulation by operating gates, the induced storage results from restricted capacity of the outlet. That is, the project operates entirely under "free flow" conditions. While this type of project provides a consistent, well defined control, it does not allow for changed conditions or provisions for multipurpose objectives.

(b) While it is unnecessary to prepare detailed regulation schedules for this type of project, it is necessary to define the uncontrolled operation and prepare water control documents to show its effect on downstream control and its relationship to other projects in the system.

d. Multipurpose Project Regulation. More than one water management goal or objective can be accommodated in a water control plan, and reservoir storage may be utilized compatibly for several purposes. The degree of compatibility for each of the water uses depends upon the characteristics of the river system, water use requirements, and the ability to forecast runoff. Either a single reservoir or a system of reservoirs may be regulated in a manner to insure the proper use of storage space. Water levels in impoundments may be controlled to provide sufficient storage space to control floods, as well as to store water for hydroelectric power, irrigation, navigation, municipal or industrial water supply use, water quality, propagation and preservation of fish and wildlife, recreation, and aesthetic purposes. Water levels in reservoirs and in rivers downstream from projects may also be regulated to achieve the desires and requirements for public use, recreation and to support fish and wildlife needs. The melding of all of the above-mentioned uses is reflected in the water control plan. In many cases, the uses are somewhat conflicting, and some degree of compromise is required to achieve the water management goals. There



is, however, a generally recognized priority for each of the major uses, whereby the defined project benefits are assured to the greatest extent possible. The balancing of water use demands and priorities are defined in the water control plan.

e. System Control. The control of projects to meet water control objectives may be considered for a single river or for a river system consisting of several tributaries, with multiple projects located on the main river or the tributaries. Normally, the control of a multiproject system requires an integrated water control plan whereby projects are regulated jointly in order to achieve the overall river basin management objectives. In such cases a master water control manual is prepared to define system regulation. Where river systems are interconnected hydraulically or electrically, particularly when hydroelectric power is a major operating element, the water control plan may encompass requirements which extend beyond a single river basin boundary and entail regional water or power requirements.

f. Minimum Streamflow. Increasing importance has been attached to the attainment of minimum streamflows during the last several decades as experience has been gained in the management of water resource systems. Specific areas of concern include instream flow requirements, water rights, navigation, hydropower, water quality, water supply, fish and wildlife, recreation, aesthetic considerations, and drought periods. In many cases, minimum streamflow which satisfies some or all of the above areas of concern is defined as a project purpose in the authorizing documents. Some projects, however, have no formal commitment for minimum streamflow due in large part to the lesser importance which was placed on instream flow requirements, water quality, fish and wildlife, recreation, and aesthetic considerations in the early development of some river basin water management systems. Lack of formal commitment does not preclude the responsibility to define and establish minimum streamflow objectives that may be achieved without jeopardizing authorized project purposes. When minimum streamflow goals and objectives are established they should be based on analyses which consider all project and system impacts to attain the best use of a limited resource. In a multiple purpose project or system of projects operation to satisfy one purpose may satisfy other requirements. For example, water released for irrigation may satisfy other instream requirements, given adequate quantity and quality, until diverted from the river.

2-2. Flood Control

a. Historical Background

(1) General. Federal flood control activity took definite form by establishment of the Mississippi River Commission in 1879, with jurisdiction over navigation work and flood control related thereto on the lower Mississippi River. Federal construction of flood control improvements was extended outside the Mississippi Valley for the first time in 1917, when a project for the Sacramento River, CA was authorized. Following the disastrous flood of 1927, the 1928 Flood Control Act authorized a comprehensive plan for control of the Mississippi River and tributaries. The following legislation marked the beginning of Corps construction and responsibility for Federal flood control projects throughout the nation.

(2) 1936 Flood Control Act

(a) Section 1 of this act declared flood control to be a proper Federal activity; that improvements for flood control purposes are in the interest of the general welfare; and that the Federal government should improve or participate in the improvement of navigable waters or their tributaries for flood control "if the benefits to whomsoever they may accrue are in excess of the estimated costs, and if the lives and social security of people are otherwise adversely affected" (49 Stat. 1570, 33 U.S.C. 701a).

(b) Section 2 set forth the jurisdiction of Federal activities and prescribed among other things, "That, hereafter, Federal investigations and improvements of rivers and other waterways for flood control and allied purposes shall be under the jurisdiction of and shall be prosecuted by the Army Department under direction of the Secretary of Army and supervision of the Chief of Engineers" (49 Stat. 1570, 33 U.S.C. 701b).

(c) Section 3 stipulated for the projects authorized therein what have become known as the "a-b-c" requirements of local cooperation; that local interests should: (a) provide without cost to the United States all lands, easements, and rights-of-way necessary for the construction of the project, except as otherwise provided herein; (b) hold and save the United States free from damages due to the construction works; (c) maintain and operate all the works after completion in accordance with regulations prescribed by the Secretary of Army (49 Stat. 1571, 33 U.S.C. 701c). Requirement (b) was amended by Sec. 9 of the Water Resources Development Act of 1974 (Pub. Law 93-251).

(3) 1944 Flood Control Act. Section 7 of this act specified that the Secretary of the Army shall prescribe regulations for the use of storage allocated for flood control or navigation at all reservoirs constructed wholly or in part with Federal funds, including those of the Tennessee Valley Authority when the lower Ohio or Mississippi Rivers are in danger of flooding; i.e., this law created a specific requirement for reservoirs that include flood control which is funded, at least in part, by Federal agencies other than the Corps. The act provided for developing flood control plans, allocating project costs to the flood control function, and regulating the projects to assure flood control benefits as determined by the Corps. All Bureau of Reclamation (USBR) projects constructed after (and some prior to) 1944, where flood control is one of the project purposes, are included in the provisions of this act. Projects that come under the authority of this legislation are generally referred to as "Section 7" projects. (58 Stat. 893, 33 U.S.C. 709.)

b. Flood Control Measures. Control of floods by structural remedies, such as reservoirs, levees, drainage systems, channel improvements, etc., has long been a national objective. In recent years nonstructural means, such as flood plain zoning, flood proofing or flood insurance, have been incorporated into overall flood control plans to augment structural control. In the operational phase of all of these measures, the overall objective is to minimize flood damage in a given region. Most structural alternative measures to control floods and alleviate flood damage require specific water control plans of operation based on current hydrometeorological conditions, flood control objectives, and the capabilities of appropriate flood control facilities. Unusually large floods may require flood fight activities or other special measures to meet flood control objectives. Streamflow forecasting is an important element in the management of water during floods, and timely use of flood forecasts provide a means for reducing damage in unprotected areas by evacuating people and moveable goods from flood areas. The management of river systems must integrate the information on all aspects of flood control outlined above in order to best manage the control works. Specific flood control measures and objectives are discussed briefly in the following paragraphs. Types of facilities and their requirements are discussed in Chapter 4.

c. Impoundments. A principal structural remedy for flooding is control of streamflows and river levels by impounding runoff. The planning of reservoirs and other impoundments to meet flood control objectives involves hydrologic studies of historical and hypothetical floods, various alternatives in storage capacities and location, downstream flood control objectives, inflows from uncontrolled drainages below the project, channel capacities, flood damage

surveys, cost-benefit determinations, and a general plan of regulation to meet the flood control requirements. These planning studies are used to determine the size and location of impoundments, the degree of protection to be provided and the multipurpose uses of projects. They are based on the overall evaluation of river basin development considering economic, environmental and social values. In the design phase, the project studies are refined, and detailed studies are made to determine design of hydraulic features and the water control plan for the project.

d. Objectives for Reservoir Control of Floods

(1) Reservoirs are seldom designed to provide complete protection against extremely large floods, such as the Standard Project Flood. However, the storage capacity is usually sufficient to reduce flood levels resulting from such an event to moderate levels and to prevent a major flood disaster. Reservoirs are usually capable of storing the entire runoff from minor or moderate flood events. The water control plan defines the basic goal of regulation, relative to control of minor and major floods. Usually a compromise is achieved in the water control plan to best utilize the storage space in reservoirs for control of both major and minor flood events. In special circumstances where reservoir inflows can be forecast several days or weeks in advance (for example, when the runoff occurs from snowmelt), the degree of control for a particular flood event may be determined on the basis of forecasts to best utilize the storage space. Also, the amount of flood control storage space may be varied seasonally when runoff is seasonal, in order to utilize the reservoirs for multipurpose regulation.

(2) One of the problems of reservoir control of floods is the requirement for post flood evacuation of stored water. This may result in long duration of river levels at or near bankfull or minor damage stages at downstream control points. The water control plan must account for this requirement, which may entail a compromise between a rapid evacuation of stored water for assuring control of subsequent flood events, and a slow evacuation to allow downstream river levels to recede below bankfull stages as quickly as possible.

e. Reservoir Systems

(1) A multireservoir system is generally regulated for flood control to provide flood protection both in intervening tributary areas and at downstream main stem damage areas. The extent of reservoir regulation required for protecting these areas depends upon local conditions of flood damage, uncontrolled tributary drainage, reservoir storage capacity, and the volume and time distribution of reservoir inflows. Either the upstream or downstream requirements

may govern the reservoir regulation, and usually the optimum regulation is based on the combination of the two. Reservoir releases are based on the overall objectives to limit the discharges at the control points to predetermined damage levels. The regulation must consider the travel times caused by storage effects in the river system and the local inflows between the reservoir and control points. Since each flood event is caused by a unique set of hydrometeorological conditions, the plan of regulation for a reservoir system for flood control should be based on a specific analysis of that particular flood event. This is most easily achieved by modeling the conditions of runoff and reservoir regulation through computerized simulation techniques and determining the control of streamflows at each project in the simulation, in order to achieve the desired downstream control and meet the water control management objectives at each reservoir.

(2) System control can incorporate the concept of a balanced reservoir regulation, with regard to filling the reservoirs in proportion to each reservoir's flood control capability, while also considering expected residual inflows and storage available. Evacuation of flood water stored in a reservoir system must also be accomplished on a coordinated basis. Each reservoir in the system is drawn down as quickly as possible to provide space for controlling future floods. Water control diagrams containing regulation criteria in the form of guide curves and regulation schedules for individual reservoirs are used as guides to define various amounts of storage space as primary and secondary flood control storage. The objectives for withdrawal of water in the various zones of reservoir storage are determined to minimize the risk of encroaching into the flood control storage and to conserve water for future requirements.

f. Levees

(1) Flood protection of land adjacent to rivers is often accomplished by means of levees. Planning and design of these structures are based on several categories of engineering and economic studies involving: (a) hydrologic studies and economic investigations of floods, local drainage, and flood damages; (b) construction materials, foundations, and alternative structural design studies; (c) design of facilities for interior drainage behind the levees; and (d) cost and benefit evaluations. The river control works may involve channel improvements and bank protection facilities. The degree of protection provided by levees is based on planning and engineering considerations as well as the type of area being protected. Design criteria allow for freeboard above the design water surface elevation to account for uncertainties in computed water levels, settlement of levees, etc., in determining the design height to which the levees are constructed. The amount of

freeboard is also dependent upon the type of area being protected. Levees which protect urban areas are usually designed with a high degree of protection (up to Standard Project Flood, if possible) because of the severe hazard and the potential for loss of life in the event of a levee failure.

(2) While most levee projects do not require day-to-day water management, it is important that managers of water control systems be properly appraised of the status of levee projects in conjunction with the overall control of a water resource system. Particularly in times of major floods, the Water Control Center (WCC) or water management element should be alerted to any signs of weakness in the levee system. The WCC should disseminate overall evaluation of flood hazard areas in conjunction with the regulation of reservoirs or diversion structures. Also, flood fighting activities, which involve special precautions to insure the safety and integrity of levees, require the coordinated efforts of the WCC, Operations Division, Emergency Management and other appropriate organizational elements. The latest forecasts of river levels and anticipated potential of future flooding may be assessed and disseminated to the field forces. In some cases, special requirements are incorporated into the design of levees for placing temporary bulkheads at street or highway crossings, or sandbagging vulnerable locations to insure the continuity of protection by the levees. Inasmuch as this must be accomplished ahead of the flood event, it is essential that actions taken to relay and utilize forecasts of anticipated river levels and flood potentials be coordinated.

g. Combined Impoundment and Levee Systems. Flood protection is provided in many river basins through the combined effects of reservoir, other impoundments and levee systems. The design of combined systems is based on planning and engineering considerations that encompass a complete analysis of river basin development. The degree of protection afforded by either levees or impoundments is often limited by economic or social considerations. The height to which levees can feasibly be built may be limited by foundation conditions, construction material availability, feasible rights-of-way, and overall cost-benefit analysis. Similarly, the degree of protection which can be provided by impoundments is limited by the availability of suitable sites, engineering and economic considerations, and social constraints in project development reservoirs. River basin studies determine how the combined use of impoundments and levees may offer a practical and economic solution for providing flood control. Management of combined systems of this type to achieve water control objectives involve the same principles as outlined in the preceding paragraphs for flood protection by impoundments and levees.

h. Local Protection Projects. The following types of projects, when constructed by the Corps, are usually turned over to local interests for operation and maintenance (O&M) after their completion. Those that are transferred to local interests are subjects to Part 208.10, Title 33, of the Code of Federal Regulations, which stipulates the requirements for O&M but is silent in regard to water control management. If either flood control or navigation is a project purpose, the Corps must prescribe the regulation in this regard, and water control procedures for any other authorized purposes are usually offered. This documentation is in the form of Standing Instructions to the Project Operator for Water Control, which is discussed in Chapter 9.

(1) Interior Drainage Systems

(a) Areas protected by levees often include the requirement for drainage of water resulting from seepage of water through the levees or storm runoff from local uncontrolled inflows which drain into the channels behind and on the protected side of the levees. The design of drainage systems to control this type of flooding is based on use of pumping plants, tide or "flap" gates, or temporary storage of water in low-lying areas or channels which are not subject to flood damage. Adequate channels must be constructed to convey the water to the outlets or control structures. The capacities of the various features are determined from studies of runoff from storm rainfall or seepage that might reasonably occur during flood conditions on the main river for which levee protection is being provided.

(b) The facilities constructed for the control of flooding in interior drainage systems often operate automatically and only require surveillance of physical operation during times of floods. As in the case of levee protection, inspections and maintenance of the facilities are also required for assurance of proper physical operation during times of flood.

(2) Diversion and Bypass Structures

(a) Temporary diversions are often required to accommodate the construction of projects. In some river systems, however, excess flood water or water supply is diverted away from the main river channel by means of a permanent diversion or bypass structure and auxiliary channels for the purpose of reducing flood flows and river levels at main stem damage centers. The permanent structures are usually located in flood plain areas, where river slopes are relatively flat. The control structure is usually located adjacent to the main river channel for diverting water into the auxiliary channels. In many cases these structures are seldom used, or pass only nominal amounts of water. However, in some cases vast amounts

of streamflow are diverted during flood periods, moderate amounts during low flow periods, and continuously in rare cases. The diversion of water may be controlled through use of control gates, pumps, or the structure may be designed for uncontrolled operation which depends upon the water level in the main river. The capacity of the structure is determined by engineering studies of desired flood stage reduction and downstream channel capacities in the main river and in the auxiliary channels, in connection with the overall plan of flood control which may involve levees and impoundment projects upstream. The auxiliary channels may be improved to provide the required flow capacity without flooding adjacent areas, or they may be unimproved natural overflow channels. The degree of improvement depends upon the frequency of flooding, land use, and economic factors.

(b) Water control management of diversion and bypass structures is very important in controlling release of water through gated structures. It is critical that the timing and use of the structure for diverting flood flows be determined on the basis of the best forecasts of river flows and flood conditions. In some cases, the auxiliary channels are designed to be used only under maximum flood conditions because of adverse effects of flooding along the auxiliary channels. For this reason, they should be utilized only when design floods are anticipated or other conditions warrant their use. Decisions to use the structures should be based on the most complete basic data and technical evaluations available.

(c) Diversion and bypass structures which have ungated spillways or sluices do not require specific water control decisions, since the flow of water through the structure is determined solely by water levels in the river. It is important, however, to anticipate the time when the facilities will operate in order to provide warnings to the people living along the auxiliary channels and to take other actions as necessary.

### (3) Hurricane and Tidal Barriers

(a) These facilities are flood control projects, which provide protection against water levels and surges resulting from hurricanes or severe storms, and are located along the ocean coastlines, across tidal estuaries, or along the perimeter of very large lakes with long fetches. These projects consist of rock-lined earthen dikes and/or concrete walls and control structures that confine the water and thereby prevent flooding which would occur from unusually high water caused by storm surges and wave action. Flooding resulting from such occurrences is usually of short duration, ranging from a few hours to as much as a day or two. Although these barriers are generally designed to provide protection against a rare combination of strong



winds and high tides, these are unusual events, and most of the regulation activities at these barriers are associated with intense low pressure systems common to all parts of the country.

(b) The facilities protect low lying areas from inundation and wave action, together with control structures, to permit drainage of interior runoff during nonflood periods. In estuaries a movable barrier (sector, tainter or flap gates) may be incorporated into the design to permit navigation through the structure during normal conditions. During tidal flooding this movable barrier closes off the navigation channel to preserve the integrity of the barrier system as a whole. During this closure the interior runoff is either discharged by pumps through the structure or temporarily stored behind the barrier.

(c) In most cases the Corps retains ownership and control of those elements of the barriers which contain navigation facilities; however, the local communities are usually responsible for the O&M activities for barriers that do not contain navigational features.

(d) The management and control of barrier systems requires a water control plan for regulating the structures, including pumping stations, vehicular gate openings, sewer lines and sea water intakes. Also, in cases where such a system involves protection of an estuary where water levels are affected by rivers or tributaries draining into the estuarine channels, the water control plan may involve the overall management of the river system. Forecasts of controlled or uncontrolled tributary inflows may be an important element in the plan.

### 2-3. Navigation

a. Historical Background. Historically, improvements of national waterways for navigation was an early concern in water resource development in the United States. The first artificial waterways were built in the northeastern United States in the late 18th century and early 19th century by private developers. Federal involvement became a matter of national policy because of the use of waterways for interstate commerce, as well as national and international trade. Over the past century and a half, the Federal government through the Corps of Engineers has been involved in the improvement for navigation of some 22,000 miles of inland and coastal waterways. Types of navigational improvements include canals, locks, dams and reservoirs; maintained channels and estuaries; bank protection, pile dikes, and other forms of channel stabilization. Making reservoir releases to increase river levels and thereby improve channel depths is another type of navigational improvement.

Specific developments in a particular river may involve several of the above-mentioned methods in providing overall navigational improvements. Although the requirements are related mainly to commercial navigation, there are also navigational needs of the general public for small boat operation and recreational use. Commercial needs range from those of intra-river transportation by small draft barges and tows to deep-draft ocean going vessels for general use.

b. Water for Navigation

(1) General. Problems related to the management of water for navigation use vary widely among river basins and types of developments. Control structures at dams, reservoirs, or other facilities where navigation is one of the project purposes must be regulated to provide required water flows and/or to maintain project navigation depths. Navigational requirements must be integrated with other water uses where developments encompass multipurpose water resource systems. In the regulation of dams and reservoirs, the navigational requirements involve controlling water levels in the reservoirs and at downstream locations and providing the quantity of water necessary for the operation of locks. There also may be navigational constraints in the regulation of dams and reservoirs with regard to rates of change of water surface elevations and outflows. There are numerous special navigational requirements that may involve water control, such as ice, undesirable currents and water flow patterns, emergency precautions, boating events, launchings, etc.

(2) Water Requirements for Lockage and Controlled Canals

(a) Navigation locks located at dams on major rivers generally have sufficient water from instream flows to supply lockage water flow requirements. Navigation requirements for downstream use in open river channels may require large quantities of water, metered out over a long period of time (from several months to a year), to achieve a significant, continuous increase in water levels for boat or barge transportation. Usually, water released from reservoirs for navigation is used jointly for other purposes, such as hydroelectric power, low-flow augmentation, water quality, enhancement of fish life, and recreation. Seasonal or annual water management plans are prepared which define the use of water for navigation. The amount of stored water to be released depends on the conditions of water storage in the reservoir system and downstream requirements or goals for low-flow augmentation, as well as factors related to the all the uses of the water in storage.

(b) Navigational constraints are also important for short-term regulation of projects to meet all requirements. In some rivers, supply of water for lockages is a significant problem, particularly during periods of low flow or droughts. The use of water for lockages is generally given priority over hydropower or irrigation usages. In critical low-water periods, a curtailment of water use for lockages may be instituted by restricting the number of lockages and thereby conserving the utilization of water through a more efficient use of the navigation system. Water requirements for navigation canals are based on lockages and instream flows as necessary to preserve water quality in the canal.

c. Water Releases for Navigation in Open Rivers. Water released from storage reservoirs to increase long-term downstream flows for navigational purposes may be a major factor in a water control plan that is based primarily on the requirements for hydroelectric power. Also, daily fluctuations in outflow resulting from power peaking operations may be constrained by navigational requirements for minimum water levels at downstream locations. These restrictions may apply to both daily and weekly fluctuations in streamflows and water levels and are determined by requirements for navigation, boating, and public use of the waterway.

d. Winter Navigation. Winter navigation poses a special problem for water control management. The goal of an effective winter navigation plan is to control ice to maintain winter navigation as long as possible using structural, operational and water management methods. This plan must also indicate when a project can no longer manage ice and navigation should stop. This winter navigation management plan should be considered for integrating into the water control plan for the total waterway system.

#### 2-4. Hydroelectric Power

a. Historical Background. Hydroelectric power is a major element of many water resource projects developed by the Corps of Engineers. Major construction of hydroelectric facilities by the Corps began with the Federal development of the Tennessee River in 1918. Full-fledged national involvement in hydropower facilities by the Corps began in the 1930's as part of the national program for comprehensive water resource development. This role was expanded after the end of World War II, with many major power plants constructed in the Pacific Northwest, Midwest, and southern portions of the United States. Geographically, about 65 percent of the capacity is located in the Columbia River Basin in the Pacific Northwest; 9 percent is located in the Missouri River Basin; 15

percent in the lower Mississippi River Basin in the south-central United States; and about 10 percent is in the Southeast. This comparison indicates that the importance of hydropower varies widely from region to region, depending primarily upon the potential for developing this resource and alternative energy sources.

b. Hydropower Evaluation. The methods for evaluating hydropower capabilities, justification, power values, and power system operation are contained in EM 1110-2-1701. The reader is referred to that publication for details on hydropower systems and the planned use of water for producing electrical energy.

c. Types of Projects

(1) Dam and reservoir projects which incorporate hydropower generally fall into two distinct categories: (a) storage reservoirs which have sufficient capacity to regulate streamflows on a seasonal basis and (b) run-of-river projects where storage capacity is minor relative to the volume of flow.

(2) The storage projects are usually multipurpose, with water requirements for flood control, irrigation, navigation, municipal and industrial water supply use, fish and wildlife, recreation as well as hydropower. Normally, the upstream reservoirs include provisions for power production at the site, as well as for release of water for downstream control. Run-of-river hydropower plants are usually developed in connection with navigation projects.

(3) In addition, power facilities may be developed in off-stream water supply channels or irrigation works. In high mountain areas, off-stream diversions may be used for high-head power plants. These are likely to be single purpose projects. Also, "pumped storage" plants may be developed to utilize off-peak energy in an electrical, which is less costly, for pumping water to a storage reservoir in times of surplus energy and then releasing the water from storage to help meet peak system power demands. Under certain conditions hydropower could be developed from tidal fluctuations in bays or estuaries, but this has not yet been accomplished in the United States.

d. Integration and Control of Federal Hydropower Systems

(1) Integration and control of a major power system involving hydropower resources is generally accomplished by a centralized power dispatching facility. This facility contains the equipment to monitor the entire power system operation, including individual plant generation, substation operation, transmission line operation, power loads and requirements by individual utilities and other bulk power

users and all factors related to the electrical system control for moment-to-moment operation. The dispatching center is manned on a continuous basis, and operators monitor and control the flow of power through the system, rectify outages, and perform all the necessary steps to assure the continuity of power system operation in meeting system loads.

(2) Regulation and management of hydropower systems involve two levels of control, scheduling and dispatching. The scheduling function is performed by schedulers who analyze daily requirements for meeting power loads and resources and all other project requirements. Schedules are prepared and thoroughly coordinated to meet water and power requirements of the system as a whole. Projections of system regulation, which indicate the expected physical operation of individual plants and the system as a whole, are prepared for one to five days in advance. These projections are updated on a daily or more frequent basis to reflect the continuously changing conditions of power and water requirements.

e. Non-Federal Development of Hydropower at Corps of Engineers Projects

(1) The Federal Power Act as amended on 1 April 1975 delegates to the Secretary of the Army and to the Commander, USACE certain functions necessary for the Federal Energy Regulatory Commission's (FERC) administration of the Act. ER 1110-2-1454 provides policy and guidance for review of preliminary permit and license applications for non-federal development at or affecting Corps projects.

(2) The Corps fully supports installation of hydropower by non-federal entities at Corps' projects, through FERC licensing procedures, so long as this renewable resource is developed in a systematic manner consistent with other authorized functions of these public projects and provided the addition of hydropower does not impact on the safety and integrity of existing Corps' structures. As a general policy compatible with the Federal Power Act, development of non-federal hydropower at the Corps' projects requires that total power potential of a site be considered. This potential can be developed in stages as the local and regional demand for electric power indicates. However, the first stage design and construction should include provisions for future expansion of power facilities compatible with the total power potential at a site and other project uses.

(3) In the interest of hydropower operation compatible with other authorized functions of the Federal project, FERC, upon recommendation by the Corps, will require the licensee to enter into a Memorandum of Agreement with the Corps describing the mode of

hydropower operation acceptable to the Corps. The FERC Regional Engineer shall be a party to these decisions. This Memorandum of Agreement shall be subject to revision by mutual consent of the Corps and licensee as experience is gained by actual project operation. The Memorandum of Agreement should be negotiated between the Corps District Commander, FERC Regional Engineer and the licensee. The negotiated agreement should be forwarded to the Corps Division Commander for approval. Upon approval by Corps Division Commander, the document will be transmitted to the FERC Regional Engineer and the licensee for concurrence and a request that tracings of the agreement be signed and returned to the Corps Division Commander. The original signed agreement along with the Plan of Regulation shall be kept on file in HQUSACE, Washington, D.C. Signed copies of the agreement will be provided to each party.

## 2-5. Water Supply

### a. Irrigation

#### (1) Historical Background

(a) In the arid and semi-arid regions of the western United States, the use of water for irrigating arable lands has been a major factor in developing water resource systems. The seasonal nature of precipitation and the lack of rainfall in the growing season led to the development of agricultural water supplies following the turn of the century. Initially these projects were instituted on a local basis by individuals, but as the size and complexity of the developments increased, it became necessary to institutionalize these arrangements. This originated first at the local and state levels of government, but federal action was initiated by the Carey Act of 1894. Subsequently, the United States Reclamation Act of 1902 provided the means for federal involvement in planning and developing reclamation projects on both privately and federally owned agricultural lands. In principle, the act provided for interest-free loans for the construction of local irrigation projects.

(b) Initially, development of irrigation projects using surface water depended upon diversions from the natural flow of the rivers. As the developments increased in size, reservoirs were constructed to increase the dependable flow of the rivers, thereby assuring water supplies on an annual or multiyear basis when the natural flow was insufficient to meet demands. Initially, the reservoirs were constructed as single purpose developments for supplying water only for irrigation, but later multipurpose developments were conceived which better utilized the water resources available. Section 8 of

the Flood Control Act of 1944 provided that Corps reservoirs may include irrigation as a purpose in 17 western states.

(2) Water Duty. The amount of water required to meet the demands for growing crops for the entire season is termed the water duty. This is equal to the total amount of water supplied to the land by means of gravity diversions from rivers or reservoirs or pumped from rivers, reservoirs, or underground sources of water. Net duty is the amount of water delivered to individual farm units, considering losses in canals, laterals, and waste from the point of diversion to the point of application on the land. In the western United States, the water duty ranges from about 1 to as much as 7 acre-feet per acre annually.

(3) Water Diversion Requirements and Return Flows

(a) Irrigation water diverted from reservoirs, diversion dams, or natural river channels is controlled in a manner to supply water for the irrigation system as necessary to meet the water duty requirements. The requirements vary seasonally, and in most irrigated areas in the western United States, the agricultural growing season begins in the spring months of April or May. The diversion requirements gradually increase as the summer progresses, reaching their maximum amounts in July or August. They then recede to relatively low amounts by late summer. By the end of the growing season, irrigation diversions are terminated, except for minor amounts of water that may be necessary for domestic use, stock water, or other purposes.

(b) The return flow of water from irrigated lands is collected in drainage channels, where it flows back into creeks and natural river channels. This return flow augments the prevailing river flow, and, depending primarily on quality, the return flow may be "re-used" for downstream irrigation or to supply some other water use function. The amount of return flow averages about 50 percent of the water diverted for irrigation purposes, but it may vary from about 20 to 70 percent.

(4) Reservoir Regulation for Irrigation

(a) Corps of Engineers reservoir projects have been authorized and constructed primarily for flood control, navigation, and hydroelectric power. However, several major Corps of Engineers multipurpose reservoir projects west of the Mississippi River include irrigation as a project purpose. Usually, water for irrigation is supplied from reservoir storage to augment the natural streamflows as required to meet irrigation demands in downstream areas. In some cases water is diverted from the reservoir by gravity through outlet

facilities at the dam which feed directly into irrigation canals. At some of the run-of-river power or navigation projects, water is pumped directly from the reservoir for irrigation purposes.

(b) The general mode for regulation of water supply reservoirs to meet irrigation demands is to capture all runoff in excess of minimum flow demands during the spring and early summer. This usually results in refill of the reservoirs prior to the irrigation demand season. The water is held in storage until the natural flow recedes to the point where it is no longer of sufficient quantity to meet all demands for downstream irrigation. At that time, the release of stored water from reservoirs is begun and continued on a demand basis until the end of the growing season (usually September or October). During the winter, projects release water as required for instream flows, stock water, or other project purposes.

b. Municipal and Industrial Water Supply Use

(1) Basic Requirements

(a) Many Corps of Engineers reservoir projects supply water for municipal and industrial use (commonly termed M&I) as an authorized function. For those projects, the requirements constitute a firm commitment for reservoir storage to be used as a source of water supply to meet stated demands. For projects where M&I is an authorized function, the costs and benefits related to construction, operation, and maintenance are shared by local water users with other project functions, in accordance with long-term contractual agreements. In some projects, M&I water may be withdrawn from reservoirs under contractual arrangements that do not involve a commitment for the "use of the reservoir storage space". These withdrawals are considered to be from natural flow or from water in excess of the needs for other project functions.

(b) Chapter 7 of ER 1105-2-20 defines the objectives, policies, rights to storage, repayments, contractual requirements, and other aspects of plan formulation involved in incorporating water supply for M&I use into Corps of Engineers reservoirs. The policies stem largely from Sections 310(a) and (b) of the Water Supply Act of 1958. ER 1105-2-20 recognizes three general classifications of the use of M&I water supply from Corps of Engineers reservoirs: (a) Permanent Rights to Storage, which may be obtained by local interests under Public Law 88-140, through water supply contracts for use of specific amounts of reservoir storage space; (b) Surplus Water (i.e., water surplus to that required to fulfill the needs of authorized project purposes), for which Section 6 of the Flood Control Act of 1944 establishes the basis for non-Federal interests to make annual payments to cover proportional costs for operation, maintenance and



replacement; and (c) Water Withdrawal, which may be obtained by local users pursuant to provisions of 31 U.S.C. 483a, by a contractual agreement which permits the user to construct, operate and maintain facilities for withdrawing water from the project.

(2) Water Management Problems

(a) Regulation of reservoirs for M&I water supply is performed in accordance with contractual arrangements. Storage rights of the user are defined in terms of acre-feet of stored water and/or the use of storage space between fixed limits of reservoir levels. The amount of storage space is adjusted to account for change in the total reservoir capacity that is caused by sediment deposits. The user has the right to withdraw water from the lake or to order releases to be made through the outlet works. This is subject to certain rights reserved for the government with regard to overall regulation of the project and to the extent of available storage space.

(b) In times of drought, special considerations may guide the regulation of projects with regard to water supply. ER 1110-2-1941 provides policy and guidance for the preparation of drought contingency plans. Adequate authority to permit temporary withdrawal of water from Corps projects is contained in 31 U.S.C. 483a. Such withdrawal requires a fee that is sufficient to recapture lost project revenues, and a proportionate share of operation, maintenance and major replacement expenses.

2-6. Water Quality

a. Management Requirements. Water quality encompasses the physical, chemical, and biological characteristics of water and the abiotic and biotic interrelationships. The quality of the water and the aquatic environment is significantly affected by management practices employed by the water control manager. The effects of improper management are often far-reaching and long-term; may range from minor to catastrophic; and may be as obvious as a fish kill or subtle and unnoticed. It is essential that all water control management activity and especially real-time actions include valid water quality evaluations as a part of the daily water control decision process. It must be understood that water quality benefits accumulate slowly, build on each other and can become quite substantial over time. This is in contrast to the sudden flurry of benefits that can come from a flood control operation. Typically, projects built for flood control operate for flood management only 2 to 3 percent of the time and must operate for water quality to some degree all of the time. Water quality benefits can be accrued only

by integrating on a continuous basis the input of individuals with a basic knowledge and understanding of water quality, biological, chemical and physical factors as they are related to the reservoir/river environment. This is the single most important aspect of water control management for water quality; therefore, it is essential that the water control management team have members who are expert in these subjects. The linkage between the water control and water quality groups should be very close, and it is preferable that both functions reside in the same organizational element. Of near equal importance is first hand knowledge of the projects and the streams influencing and influenced by the projects.

b. Objectives and Water Quality Standards

(1) Water quality control is an authorized purpose at many Corps of Engineers reservoirs. However, even if not an authorized project purpose, water quality is an integral consideration during all phases of a project's life, from planning through operation. This Corps policy is based on Section 313 of the Clean Water Act of 1979 and Executive Order 12088, 13 October 1978, both of which require Federal compliance with applicable pollution control standards that apply to any private entity. The goal is to, as a minimum, meet State and Federal water quality standards in effect for the lakes and tailwaters. The operating objective is to maximize beneficial uses of the resource through enhancement and nondegradation of water quality. Attaining that goal requires continuous efforts at managing water quality by developing programs and objectives and performing the necessary studies, data collection, analysis, coordination, and real-time management.

(2) Water quality management objectives for new projects are defined early in the planning phase in accordance with ER 1110-2-1402. Programs to meet the objectives are subsequently developed and implemented by the start of operation of the project at the latest. ER 1130-2-415 contains guidance on the collection, interpretation and application of water quality data within the framework of the overall management program. Guidance on establishing Division-wide water quality management programs and requirements for reporting of associated water quality management activities is contained in ER 1130-2-334.

c. Monitoring Water Quality Conditions. Knowledge of water quality conditions is essential for effective water control management and therefore, continual water quality monitoring efforts are required. Data collection programs will be tailored to each project, the intent being to insure that project purposes and uses are not compromised and to monitor the effects of project regulation on lake and tailwater quality. Additionally, known or suspected

problems such as nuisance algae or priority contaminants, require special and often more intensive data collection efforts. Guidance on data collection and reporting requirements are contained in ER 1130-2-415 and ER 1130-2-334. A comprehensive treatment of all aspects of water quality monitoring and data analysis can be found in EM 1110-2-1201.

d. Water Quality Releases for Downstream Control. Water quality releases for downstream control have both quantitative and qualitative requirements. The quality aspects relate to Corps policy and objectives to meet state water quality standards, maintain present water quality where standards are exceeded and maintain an acceptable tailwater habitat for aquatic life. The Corps has responsibility for the quality of water discharged from its projects. One of the most important measures of quality is quantity. At many projects authorized for water quality control, a minimum flow at some downstream control point is the water quality objective. An appropriate level of data collection is required for project operation to insure attainment of water quality requirements through reservoir regulation activities. Coordination between water quality and water control personnel and integration of water quality into water control management procedures are essential and must be described in project water control manuals as prescribed in ETL 1110-2-251, Preparation of Water Control Manuals.

e. Selective Withdrawal Facilities for Water Quality Control

(1) Most impoundments exhibit some degree of temperature stratification. In general, deeper lakes are more likely to become highly stratified each summer and are not likely to become mixed by wind or short-term temperature changes. When the surface of the lake begins to receive a greater amount of heat from the sun and air than is lost, it becomes warmer and less dense, while the colder, more dense water remains on the bottom. In the layer of colder water near the bottom, little if any oxygen is transferred from the air to replace that depleted by oxidation of organic substances, and, eventually, anoxia may develop. Under this condition, a reducing environment is created, resulting in elevated levels of parameters such as iron, manganese, ammonia and hydrogen sulfide. Changes such as these may result in water that is degraded and toxic to aquatic life.

(2) Due to the great vertical variation in water quality, the primary means of managing the water quality of reservoir releases is to provide facilities for withdrawing water from various levels in the lake. This is accomplished by the use of intake structures with multilevel withdrawal capability. These intake facilities should be designed in accordance with ER 1110-2-1402. Project releases should

meet the desired temperature and dissolved oxygen content and other water quality criteria as nearly as possible. Establishment of these criteria is prescribed in the referenced ER 1110-2-1402. The vertical profile may be such that all criteria may not be satisfied by withdrawing from any one elevation. For example, it may be necessary to draw cold water from a lower level, where oxygen is deficient, in combination with water from a higher, warm layer to supply the required oxygen. Because of the uncertainty involved with proportioning flow through two or more intakes in a single wet well, it may be necessary to provide dual wet wells as part of the selective withdrawal facilities.

(3) Selective withdrawal structures also provide an opportunity for managing the in-lake environment. This can be accomplished by selectively withdrawing and blending good and poor quality water when the resulting product will meet the release objective. This type of integrated management will help to prevent an overloading of low quality water in the lake which could lead to a collapse of both tailwater and reservoir quality.

(4) Much research has been undertaken to address operational aspects of water quality control, such as where profiles in the lake should be taken, the withdrawal characteristics of intakes under different flow conditions, blending of flows in single wet wells, where to measure the discharge quality, etc. Detailed technical guidance is given in EM 1110-2-1201, and assistance in these matters may be obtained from the Committee on Water Quality as outlined in ER 15-2-14.

f. Water Quality System Regulation

(1) Coordinated regulation of multiple reservoirs in a river basin is required to maximize benefits beyond those achievable with individual project regulation. System regulation for quantitative aspects, such as flood control and hydropower generation, is a widely accepted and established practice, and the same principle applies to water quality concerns. Water quality maintenance and enhancement beyond the discernible effects of a single project are possible through coordinated system regulation. This applies to all facets of quality from the readily visible quantity aspect to traditional concerns such as temperature and dissolved oxygen.

(2) System regulation for water quality is of most value during low flow periods when available water must be used with greatest efficiency to avoid degrading lake or river quality. Water control decisions are formulated based on current and forecasted basin hydrologic, meteorologic and quality conditions, reservoir status, quality objectives and knowledge of water quality characteristics of

component parts of the system. Required flows and qualities are then apportioned to the individual projects resulting in a quantitatively and qualitatively balanced system. Computer programs capable of simulating reservoir system regulation for water quality provide useful tools for deriving and evaluating water control alternatives.

## 2-7. Fish and Wildlife

a. Historical Background. The Fish and Wildlife Coordination Act of 1958 as amended, provides that fish and wildlife receive equal consideration with other project purposes and be coordinated with other features of water resource development programs. The water resource construction agencies are to consult with fish and wildlife agencies on justifiable means and measures for fish and wildlife enhancement. The Corps may recommend project modifications and acquisition of lands for fish and wildlife conservation purposes. Section 2(a) of the Act defines the area of interest to include impoundment, diversion, channel deepening, or any modification of a stream or other body of water. Section 2(b) of the Act specifies that the project plan shall include such justification means and measures for wildlife purposes (mitigation and enhancement) as the reporting agency finds should be adopted to obtain maximum overall project benefits. Therefore, prevention of damages to fish and wildlife resources must be provided to the extent practicable, not only by planning and design, but by good water management practices as well.

### b. General

(1) Fish and wildlife management opportunities and problems related to water control vary widely depending upon geographical location, the management objectives and the operational capabilities of the project. The project water quality characteristics discussed previously, as well as the ability to manipulate these conditions, greatly influence reservoir fisheries and the ability to meet fish and wildlife management objectives.

(2) Most large water control projects are authorized and designed for multiple purposes and must be operated within the constraints of these purposes. However, authorized project purposes usually contain enough flexibility to permit some manipulation of water levels and reservoir releases for fisheries management and other wildlife considerations. Water control managers should take the initiative to evaluate opportunities for managing fish and wildlife habitats, by continually evaluating the effects of project regulation. This includes being aware of pool level fluctuations,

the quality, quantity and timing of project releases and the associated impact on the fish and wildlife.

(3) Developing guidance for creatively managing water control projects for fisheries is complicated by the wide range of hydrometeorological events that may occur, as well as the effects of regulation for the individual projects authorized purposes. Further complexity is introduced because habitat requirements for spawning, incubation and emergence times vary greatly among species.

(4) While the structural design of the project may limit the flexibility of regulation strategies, water control managers are tasked with the challenge of trying to meet fishery management objectives. Because of their understanding of the projects' water quality characteristics and resulting effects on reservoir or downstream fisheries, the water control manager can be in a unique position to recommend evaluation of structural modifications, possible reallocations of project storage, or modifications to regulating plans. Prior to undertaking any of these actions, the objectives and priorities for fish and wildlife management should be identified and coordinated with appropriate fish and natural resource agencies. This may include state fish and wildlife agencies, the U.S. Fish and Wildlife Service, the National Marine Fishery Service and Indian tribes. Coordination of these actions provides more effective oversight of fish and wildlife in relation to other uses of the basin, and draws upon existing experience and expertise.

#### c. Reservoir Fisheries

(1) Project regulation can influence fisheries both in the pool and downstream. One of the most readily observable influences of reservoir regulation is reservoir pool fluctuations. Periodic fluctuations in reservoir water levels present both problems and opportunities to the water control manager with regard to fishery management. The seasonal fluctuation that occurs at many flood control reservoirs, and the daily fluctuations that occur with hydropower operation often result in elimination of shoreline vegetation and subsequent shoreline erosion, water quality degradation and loss of habitat. Adverse impacts of water level fluctuations also include loss of shoreline shelter and physical disruption of spawning and nests.

(2) Some of the fishery management techniques that may be implemented include: pool level management for weed control; forcing forage fish out of shallow cover areas, making them more susceptible to predation; maintaining appropriate pool levels during spawning; decreased wide fluctuations in pool levels. The lowering of levels during spawning is sometimes also combined with rough fish removal

during drawdown to help manage for another, more desirable fishery. Wave action from slowly draining the water down can help maintain clean gravel substrates, which are favorable to some target fish species.

(3) The success of each management technique varies from region to region, and lake to lake. This variability in physical, biological, chemical and operational characteristics in addition to uncontrolled environmental influences, makes predicting the results of changes in reservoir levels and releases for fishery management difficult. Reservoir design, mode of operation, and specific life history requirements of target fishes play primary roles in determining water management strategies. Manipulation of water levels to enhance fisheries is often based on the timeliness of flooding or dewatering shoreline vegetation. Where seasonal flooding of shoreline vegetation is recommended, fishery management plans may include lowering water levels during a portion of the growing season to permit regrowth of vegetation. By regulating the timing and duration of flooding, water level management schemes can be developed for a particular reservoir which encourage the establishment of desirable innocuous macrophytes and reduce nuisance aquatic plants.

(4) A great deal of information is available to water control managers to assist them in tailoring shore vegetation management programs to their specific projects and needs. This includes information on the identification of plant species suitable for shoreline revegetation and information to determine the feasibility of revegetation at a specific project (EP 1110-1-3). In addition to stabilizing the soil, which in turn improves water quality, shoreline vegetation provides nursery grounds and cover for fish and their food organisms, food for birds and terrestrial wildlife.

(5) Water-level management in fluctuating warm-water and cool-water reservoirs generally involves raising water levels during the spring to enhance spawning and survival of young predators. Pool levels are lowered during the summer to permit regrowth of vegetation in the fluctuation zone. Fluctuations may be timed to benefit one or more target species; therefore, several variations in operation may be desirable. In the central United States, managers frequently recommend small increases in pool levels during the autumn for waterfowl management.

(6) Fall and winter drawdown is often recommended for shallow reservoirs that support large stands of water plants (aquatic macrophytes). The method is effective in concentrating prey species and controlling aquatic vegetation. Drawdowns that reduce surface area by as much as 50 percent may be desirable. As with other basic

approaches to water-level management, numerous variations have been applied.

(7) In addition to actions to achieve small pool fluctuations, periodic major drawdown has been used effectively for fishery management. This procedure involves drastic lowering of a reservoir pool level over an extended time period (at least one growing season) to permit vegetative regrowth in the dewatered zone. This may be augmented by seeding of plants to establish desirable species. Some objectives may be accomplished by selectively removing or killing various fish communities. After this, the reservoir is refilled during the spring, fish are restocked, and a high water level maintained through the summer. This technique is effective for stimulating production of desirable sport and prey fishes, but if it conflicts with authorized reservoir purposes, it may be difficult to implement.

(8) Water-level management in cold-water reservoirs has been mostly oriented toward the production and enhancement of salmonoids, with anadromous species receiving primary consideration. Important management problems relating to production of salmonoids include maintaining access to tributary streams for spawning, controlling releases to facilitate passage of anadromous species, limiting losses of important sport fishes, and stabilizing reservoir pool levels during the extended periods of egg and larval development of certain species.

#### d. Tailwater Fisheries

(1) Guidelines to meet downstream fishery management potentials should be developed for each project based on project water quality characteristics and the water control capabilities. To do so, an understanding of the reservoir water quality regimes is critical for developing the water control criteria to meet the objectives. For example, temperature is often one of the major constraints of fishery management in the downstream reach, and water control managers must understand the temperature regime in the pool and downstream temperature requirements, as well as the capability of the project to achieve the balance required between the inflows and the releases. Releasing cold-water downstream where fishery management objectives require warm water will be detrimental to the downstream fishery. Conversely, releasing warm water creates difficulty in maintaining a cold-water fishery downstream.

(2) Water control activities can also impact water temperatures within the pool by changing the volume of water available for a particular layer. In some instances, cold-water reserves may be necessary to maintain a downstream temperature objective in the late



summer months and therefore, the availability of cold water must be maintained to meet this objective. For some projects, particularly in the southern US, water control objectives include the maintenance of warm-water sports fisheries in the pool, and in some cases, cold-water fisheries in the tailwaters. In other instances, fishery management objectives may include the maintenance of a two-story fishery in a reservoir, with a warm-water fishery in the surface water, and a cold-water fishery in the bottom waters. Such an objective challenges water control managers to regulate the project to maintain the desired temperature stratification while maintaining sufficient dissolved oxygen in the bottom waters for the cold-water fishery. Regulation to meet this objective requires an understanding of operational effects on seasonal patterns of thermal stratification, and the ability to anticipate thermal characteristics.

(3) Minimum instantaneous flows can be beneficial for maintaining gravel beds downstream for species that require this habitat. However, dramatic changes in release volumes, such as those that result from flood control regulation, as well as hydropower, can be detrimental to downstream fisheries. Peaking hydropower operations can result in releases from near zero to very high magnitudes during operations at full capacity. Maintaining minimum releases and incorporating reregulation structures are two of the options available to mitigate this problem.

(4) In some instances tailwater fishing is at a maximum during summer weekends and holidays and this is a time when power generation may be at a minimum and release near zero. Maintaining a minimum releases during weekend daylight hours may improve the recreational fishing, but may reduce the capability to meet peak power loads during the week because of lower water level (head) in the reservoir. In this instance, water control managers will be challenged to regulate the project with consideration of these two objectives.

(5) Opportunities for modification of reservoir regulation increase with the complexity of the reservoir river system, (e.g., Columbia, Missouri, Lower Ohio River Basins) where reservoir regulation is highly integrated. Reservoirs regulated primarily for flood control generally provide greater flexibility for water level management than hydropower projects.

e. Fish Migration

(1) Another concern, particularly in the Pacific northwest, is the maintenance of successful migration of anadromous fish, such as salmon; similar objectives exist in the northeastern U.S. and in places where other anadromous fish such as striped bass, have become

established. Declines in anadromous fish populations have been attributed to dams due to: blockage of migration, alteration of normal stream flow patterns, habitat modification due to inundation, blockage of access to spawning and rearing areas, delays in migration rates and changes in water quality.

(2) Regulation for anadromous fish is particularly important during certain periods of the year. Generally, upstream migration of adult anadromous fish begins in the spring of each year and continues through early fall, and downstream migration of juvenile fish occurs predominantly during the spring and summer months. The reduced water velocities through reservoirs in comparison with preproject conditions, may greatly lengthen the travel time for juvenile fish downstream through the impounded reach. In addition, storage for hydropower reduces the quantity of spill, and as a result, juvenile fish must pass through the turbines. The delay in travel time subjects the juvenile fish to greater exposure to birds and predator fish, and passage through the powerhouse turbines increases mortality. To improve juvenile survival, storage has been made available at some projects to augment river flows, and flows are diverted away from the turbine intakes and through tailraces where the fish are collected for transportation or released back into the river. Barges or tank truck can be used to transport juveniles from the collector dams to release sites below the projects. Other Corps projects have been modified so the ice and trash spillways can be operated to provide juvenile fish passage.

(3) Regulation for adult fish passage may include selective operation of power units and spillway bays to control downstream flow patterns in a manner necessary to attract adult fish to ladder entrances. Additional information pertaining to the use of water control facilities to protect and enhance anadromous fisheries is included in Chapter 4.

f. Minimum Releases. The Corps is also responsible for providing established minimum releases from water control projects for maintenance of downstream fisheries and the overall downstream aquatic environment. The release influences the downstream food supply, water velocity and depth. Water control managers must often maintain minimum releases for this purpose along with minimum flow requirements for other instream requirements.

g. Reservoir Wildlife

(1) Project regulation can influence wildlife habitat and management principally through water level fluctuations. These fluctuations present both problems and opportunities to the water control manager relative to wildlife habitat and its management.

(2) The beneficial aspects of periodic drawdowns on wildlife habitat are well documented in wildlife literature. Drawdowns as a wildlife management technique can, as examples, allow the natural and artificial revegetation of shallows for waterfowl; permit the installation and maintenance of artificial nesting structures; allow the control of vegetation species composition; and ensure mast tree survival in greentree reservoirs. Wildlife benefits of periodic flooding include inhibiting the growth of undesirable and perennial plants; creating access and foraging opportunities for waterfowl in areas such as greentree reservoirs; and ensuring certain water levels in stands of vegetation to encourage waterfowl nesting and reproduction.

(3) Water level manipulations conducted without regard to effects on wildlife habitat can result in many adverse impacts. Such impacts include the destruction of emergent and terrestrial vegetation; permitting predator access to otherwise inaccessible areas, such as during drawdowns; abandonment of active nest sites; and rendering soils with iron oxides unproductive when dried out.

## 2-8. Recreation

a. Historical Background. The use of reservoir projects for recreational purposes stems from the Flood Control Act of 1944 and the Federal Water Project Recreation Act of 1965 (PL 89-72). The Federal interest in the provision of recreation opportunities at Corps of Engineers projects is limited; that is, other project purposes, such as flood control or navigation, are needed to establish Corps interest. Many projects, including those for which recreation facilities may have been included under general provisions of the Flood Control Act of 1944, as amended, do not have separable storage costs for recreation. While under these circumstances recreation is an authorized purpose, it is secondary to project functions for which the storage was formulated. Any reallocation of reservoir storage that would have a significant effect on authorized purposes or that would involve major structural or operational changes requires Congressional approval.

b. General Requirements. The general public uses reservoirs for water-related recreational activities. Also, river systems below dams are frequently used for recreational boating, swimming, fishing, and other water related activities. Regulation of project outflows must consider the effects of streamflows and water levels on these activities at the project site, in the reservoir area, and in the rivers at downstream locations. Reservoir regulation criteria include special considerations for these purposes.

c. Water Management Problems

(1) Recreational use of the reservoirs may extend throughout the entire year. Under most circumstances, the optimum recreational use of reservoirs would require that the reservoir levels be at or near full conservation pool during the recreation season. The degree to which this objective can be met varies widely, depending upon the regional characteristics of water supply, runoff, and the basic objectives of water regulation for the various water use functions. Facilities constructed to enhance the recreational use of reservoirs may be designed to be operable under the planned reservoir regulation guide curves on water control diagrams, which reflect the ranges of reservoir levels that are to be expected during the recreational season.

(2) In addition to the seasonal regulation of reservoir levels for recreation, regulation of project outflows may encompass requirements for specific regulation criteria to enhance the use of the rivers downstream from the projects, as well as to insure the safety of the general public.

d. Long-Term Seasonal Fluctuations of Reservoirs. In the West, normal flood control, navigation, or power regulation may meet recreational requirements since seasonal regulation normally permits refill of the storage space to normal full conservation pool during spring or early summer. In low runoff years, or years in which the runoff is delayed because of weather conditions, it may be impractical to meet the desired needs for full pool reservoir levels during the recreation season.

e. Control of Streamflows for Downstream Recreational Use. The Corps has the responsibility to regulate projects in a manner to maintain or enhance the recreational use of the rivers below projects to the extent possible. In the peak recreation season, streamflows should be well regulated to insure the safety of the public who may be engaged in water related activities, including boating, swimming, fishing, rafting, river drifting, etc. Also, the aesthetics of the rivers may be enhanced by augmenting streamflows in the low water period. Water requirements for maintaining or enhancing the recreational use of rivers are usually much smaller than other major project functional uses. Nevertheless, it is desirable to include specific goals to enhance recreation in downstream rivers in the water control plan. The goals may be minimum project outflows or augmented streamflows at times of special need for boating or fishing. Of special importance is minimizing any danger that might result from changing conditions of outflows which would cause unexpected rise or fall in river levels. Also, river drifting is

becoming an important recreational use of rivers, and in some cases it may be possible to enhance the conditions of streamflow for relatively short periods of time for this purpose.

## 2-9 Erosion and Deposition Considerations

a. General. Natural stream erosion and deposition processes are significantly altered through the construction and operation of dams. The impacts of individual projects vary significantly, depending on the streamflow and sediment characteristics of the parent stream, and the specific operating rules of a given project. Interruption of the natural sediment processes of a stream generally results in deposition of sediment in the upstream reservoir area, and corresponding erosion and degradation of the streambed and banks immediately downstream from the project. The location of deposits in the reservoir is a function of the size of the reservoir, the size and magnitude of the sediments being transported, and the pool level at the time of significant inflow. The amount of bank and shoreline erosion is closely related to the rate and magnitude of the pool level fluctuations. The entire erosion/deposition process impacts many project related functions, and must be recognized, considered, and carefully monitored throughout the life of a project.

### b. Downstream Considerations

(1) Large reservoir projects frequently trap and retain all of the suspended sediment and bed material load within the upstream pool, thus releasing sediment-free water. These releases, often varying from zero to maximum capacity within a very short time frame are capable of eroding both the banks and bed of the stream immediately downstream from the outlet structure resulting in a permanent loss of valley lands. The amount and rate of this erosion is related to the composition of the bed and bank material, the volume of water released on an annual or seasonal basis, the rate of these releases, and the manner in which the flow is released. Fluctuating releases often result in an initial loss of the banks, and this loss is closely related to the magnitude of the expected stage fluctuation. The recession of banks due to fluctuating releases usually stabilizes in the first few years of operation, as the underwater slope reaches a quasi state of equilibrium. Once this equilibrium slope has been achieved, the bank erosion process behaves as in the natural channel. Periodic wetting and drying of the banks through fluctuating releases accelerates this process. Reservoir releases also result in lowering of the streambed, with the maximum amount of lowering occurring immediately downstream from the outlet works, and decreasing in the downstream direction. This degradation process continues until the slope is reduced to its equilibrium value

and/or the bed becomes naturally armored by removal of the fines, which exposes the coarser, non-erodible bed materials. Once the bed becomes naturally armored, future lowering of the streambed is usually insignificant.

(2) Channels downstream from small and medium size projects often exhibit entirely different characteristics than described above, and tend to lose their channel capacity over time. Projects that make only intermittent releases over short periods of time, or low level releases over extended periods of time are candidates for extensive deposition and subsequent vegetative encroachment. This process tends to build upon itself, and once established is difficult to reverse. The once-annual flushing flows capable of removing deposits near the mouth of tributaries are often replaced by low level non-erosive releases, thus contributing to the loss of channel capacity and future operating flexibility.

c. Upstream Considerations

(1) Shoreline Erosion. Reservoir shorelines are subject to a number of forces contributing to their instability, and frequently undergo major changes throughout the life of a project. Fluctuating pool levels saturate previously unsaturated material, resulting in massive slides when the pool level is drawn down to lower levels. This material accumulates at the base of the slope, and often forms an underwater bench, leaving steep unstable slopes above the water line. Reservoir banks are also subjected to attack by both wind and waves, which tend to remove this material and undercut the banks. Protection against these forces can be a very costly endeavor, and must often be limited to specific areas of concern. Prediction of the amount and locations of severe bank erosion is an important long-term concern, as it impacts on such things as the amount of project lands that need to be purchased, location of recreation features, and general use of adjacent lands.

(2) Reservoir Deposition. Sediment deposits in the reservoir pool are an important consideration and concern, as they impact not only on the reservoir storage capacity over the life of the project, but also on many project purposes both adjacent to the pool and in the backwater reach immediately upstream from the pool. Sediment deposits are not restricted to the lower reservoir zone frequently reserved as a sediment pool, but often deposit in the multipurpose or flood control pool zones in the form of large deltas and cause a multitude of problems and concerns as the project matures. Major sediment deposits can reduce the storage reserved for flood control to such an extent that adjustment in the pool levels becomes necessary in order to maintain the flood storage capacity. The deposits also can have a significant impact on the backwater profile

of reservoir inflows over time, resulting in increased groundwater and surface water levels and flooding problems in the areas immediately upstream from the reservoir pool. The location of the sediment deposits can also affect and contribute to ice accumulations and jams which may become an operational constraint during certain times of the year. The impact of sediment accumulations in the reservoir, over the life of the project, should be recognized and accounted for in the overall planning and operation of the project.

d. Guidelines. Water control managers should be cognizant of the impacts of operating procedures on the erosion and deposition process, and should operate in such a manner to minimize both upstream and downstream adverse impacts. In order to accomplish this, it is necessary to be fully informed of all known problem areas, and the potential impact of alternative regulation decisions. Although much of the erosion/deposition process is beyond the control of the water manager, certain precautions can significantly minimize problems. These include:

- Minimize the rate of reservoir pool drawdown.
- Avoid sudden increases in project releases and subsequent downstream stage fluctuations.
- Avoid sudden cutbacks in powerplant or flood control releases and resultant stage fluctuations.
- Keep reservoir pool levels as low as possible during known periods of high sediment inflow, thus encouraging sediment to deposit in the lower zones of the pool.
- Periodically raise pool levels high enough to inundate existing sediment deposits, thus precluding the establishment of permanent vegetation and subsequent increased sediment deposits in the backwater reaches entering the pool.
- Schedule periodic releases through the outlet works to preclude sediment accumulations in and near the intake structure and in the downstream channel.
- Be aware of conditions that may impact on the erosion/deposition process, such as the potential for ice jams, tributary inflow, shifting channels, and local constraints, and adjust regulation criteria to minimize adverse impacts.

2-10. Aesthetic Considerations. The effects of reservoir regulation on the aesthetics of the river system are closely related to the public use of reservoirs and rivers and must be considered in the management of water control systems. Management of such systems may involve the mitigation of adverse effects related to the aesthetics and the general beauty of the riverine environment. Such mitigation may include establishing minimum streamflows and their related river levels, minimizing the duration of exposure of unsightly reservoir shoreline resulting from reservoir drawdown, or releasing water for special aesthetic purposes. For many water control projects, it may be virtually impossible to compensate fully for such effects and still maintain the integrity of the functions for which the projects were authorized and constructed. For some projects, adjusting water control plans to help mitigate these effects, even though they may be only a partial remedy, may be feasible. The relative importance of these considerations varies widely from case to case, and the solutions to problems involved in adjusting water control plans to meet the aesthetic goals require judgment and full knowledge of all water management functions.



## CHAPTER 3

### DEVELOPMENT OF WATER CONTROL PLANS

#### 3-1. Principles and Objectives

a. Water control facilities constructed by the Corps of Engineers, together with projects constructed by other Federal or private entities for which the Corps has responsibility for directing water regulation for flood control or navigation, constitute the major river regulation capability for the United States. Presently, there are approximately 560 dams and other water control structures constructed and operated by the Corps nationwide. There are approximately 88 non-Corps dams for which streamflows are regulated, at least in part, through the supervision and direction of the Corps. Also, there are several projects constructed through international agreements with Canada and Mexico, in which the Corps shares water regulation responsibility with boards or commissions that direct the management of the water control facilities. All of these projects have an effect on the control, management and use of the river systems of the United States, and the control that they provide constitutes the principal means for achieving water management goals for the greatest beneficial use of the nation's rivers. Management of these water resource developments is a major Federal responsibility, and the Corps, through its mandated responsibility for the planning, design, construction and operation of water resource projects on a national basis, must direct the water management activities on the basis of sound engineering practice. The Corps has many years of experience in water resource development and, as a result, has a sound technical background for carrying on water management programs that best utilize the Nation's water resources.

b. The development of water control criteria for the management of water resource systems stems from the earliest planning studies of river basin development and continues through the various steps in investigating, justifying, authorizing, designing, and constructing the water control projects. Even after the projects have been constructed, there may be further refinements or enhancements of the water control procedures, in order to account for changed conditions resulting from new requirements, additional data, or changed social or economic goals. Throughout the life of the project, it is necessary to define the water control criteria in precise terms at a particular time, in order to assure carrying out the intended functional commitments in accordance with the authorizing documents. For this reason, documents related to water regulation

are prepared during the various stages of project development to assure that the projects are regulated in accordance with the design criteria and agreed upon procedures.

c. Throughout the nation, the variety of projects and conditions related to water control makes it impossible to develop a single set of water management rules which apply to all projects. Each region or river basin has its own unique requirements which need to be addressed. Furthermore, there is a wide range among projects. For example, the types of criteria required for a series of single purpose locks and dams designed for improving navigation, as opposed to the criteria required for large multipurpose reservoir systems involving several projects and complicated interactions among the various water uses. Nevertheless, for all projects there is an over-riding requirement that methods used in developing water control plans be performed in accordance with general principles and guidelines established as consistent policy for all projects. It is the purpose of this chapter to outline the various steps and technical considerations necessary to develop water control plans, whereby the engineers involved in these programs may apply them to their particular projects or systems.

### 3-2. Water Control Plans

#### a. General

(1) The water control plan addresses the needs and methods for determining a plan of regulation considering all water management goals (functional, environmental, social and aesthetic), as well as various techniques, organizations, systems and facilities involved in the regulation of water projects. The principle guides for scheduling project regulation are the basic criteria discussed in Section 3-3.

(2) The organization and staff required to carry out water control functions are also dealt with in the water control plan. Each river basin development and Corps office has its own unique circumstances and meets its own staffing and organizational requirements for water management activities. General guidelines are set forth in existing policies and regulations. For major river system regulation with multipurpose requirements, water management involves many activities which support the process of scheduling project regulation. These include specialized elements which develop project regulation procedures, system modeling, hydrologic analysis, and functional water use studies such as flood control, hydroelectric power, water quality, etc. These specialists perform evaluations and

studies of current operations which are used for updating annual operating plans and seasonal schedules.

b. Integration of Water Quality into the Water Control Plan

(1) Integration of water quality control into the initial water control plan requires carefully designed preimpoundment studies and extensive analysis of preproject conditions. These efforts are coordinated with State and Federal resource agencies and support the development of reasonably accurate predictions regarding the quality of reservoir inflows, storage, discharge and downstream impacts. Subsequently, a water quality control plan is developed.

(2) Predictions of reservoir inflow conditions are based on investigations of the watershed and the quality of surface waters and, perhaps, groundwater quality. Such investigations must consider past, present and future land use activities (agriculture, mining, industry, etc.) in order to identify all possible parameters that may impact reservoir storage conditions. Water quality data must include biological as well as physical and chemical measurements and must be collected during a reasonably complete range of hydrologic conditions including wet and dry. A comprehensive data base including water quality, hydrology and meteorology is essential for application of math modeling procedures.

(3) These preimpoundment studies along with coordination with the resource agencies must also consider downstream conditions, water use needs and resource management objectives. Water quality measurements and operating targets such as water supply, aquatic habitat or fisheries may need special studies. This data base will aid in development of the water quality control plan and support investigation of any post-impoundment impacts whether anticipated or not.

(4) Acceptable predictive techniques require application of an appropriate mathematical model or models. These techniques provide reasonably accurate predictions of the physical, chemical and biological characteristics of impoundments. These studies provide design criteria for water quality control structures such as selective withdrawal and predictions of discharge quality.

(5) Subsequently, the above studies and information will be used to develop a comprehensive operating plan that will best meet the overall water quality, environmental and resource management objectives. These objectives will include both downstream and reservoir users and benefits. In addition, a post-impoundment plan for monitoring inflow, reservoir and tailwater conditions will be developed. These monitoring activities will provide data for daily

operating decisions, evaluating long-term trends or changes in water quality conditions and tracking the effectiveness of the operating plan. This information will be included in water control manuals.

c. Annual Water Management Plans. Annual water management plans represent application in detail for the current operating year for multi-purpose regulation. They are used to define guide curves for water supply functions, such as hydroelectric power, irrigation, navigation, water quality, etc., based on the current conditions of water management for the current year. The annual water management plan may be used to develop an outlook for regulation for more than one year in advance, but the plan is revised annually. The methods of system analysis used in developing the annual plan are essentially the same as those used in planning and design studies.

d. Input from Other Water Regulation Interests

(1) Usually, management of water control systems by the Corps involves input from other agencies of the Federal government, as well as state and local authorities, public utilities, irrigation districts, fish and wildlife interests, and other groups that are involved in environmental and public use functions of project regulation.

(2) Hydroelectric power is an example of the need for integrating project regulation with other water management entities. The water control plan for a coordinated power system requires full knowledge of all elements of the system, including estimates of loads and resources for each of the operating utilities, project and power transmission operating characteristics, methods for scheduling, dispatching, and marketing power, and a myriad of details that affect system regulation. These requirements for coordinated regulation, data inputs, and technical evaluations for achieving power regulation goals can be met by establishing coordinating bodies or groups which are voluntarily agreed upon by the parties involved. The coordination groups provide for the exchange of data and the establishment of work groups for developing coordinated project power operating plans. The water control plan for Corps projects that include hydroelectric power include descriptions of this type of data exchange with other operating utilities or power marketing agencies, as appropriate.

(3) Other water use functions may similarly require data input and coordination between the Corps and special interest operating groups. Water releases for improving water levels for navigation or scheduling of lock closures, for example, must be coordinated with navigation companies. Scheduling water supplies for irrigation or M&I use require coordination and input from the using agencies to

define the specific requirements and scheduling procedures. Special water regulation may be requested by river user groups, and the water manager must appraise and recommend action based on information provided by these local groups and the effects of the proposed regulation on the overall regulation of the project. These special requests should consider all appropriate safety aspects prior to implementation.

(4) Regulation of projects must consider all aspects of the conditions of the rivers and projects, as well as at downstream locations. Many of the functional uses have far-reaching effects on water related systems involving major industries, utilities, and agricultural developments, which are dependent in some degree upon the utilization of the water resource. Furthermore, project regulation has significant effects on the use of the waterways by the general public in relation to environmental and aesthetic considerations.

e. Analysis of Drought Periods

(1) One of the principal objectives of water supply evaluations for a water resource system is to determine the regulation of the system during periods of drought. System studies for hydroelectric power, irrigation, navigation, and municipal and industrial use, singly or in combination, are largely made to determine the assured capability of projects to meet these uses during the most critical sequence of low water conditions that may reasonably be expected. These studies also may be used to determine the minimum instream flow that can be assured at downstream control points. In view of the multipurpose regulation that generally prevails for system regulation, the determination of minimum instream flow must be based on system studies which consider all of the project functions. In many cases, the functions are complementary to each other, and full use of the storage space to meet all functions provides the minimum instream flow requirements in conjunction with other uses. Streamflow augmentation in the interest of water quality is an adjunct to the minimum instream flow requirement.

(2) Determination of drought conditions, in relation to the conditions of streamflow, is usually based on the most critically severe sequence of low water conditions as determined from the historical period of record of streamflow for a particular river system. Inasmuch as the period of record of streamflow data varies widely between river systems, this criterion does not yield a consistent measure of drought severity. Hydrologic low-flow analysis may be necessary to yield consistent probabilities of low water sequences.

f. Water Control Procedures During Planning and Design. The first step in the preparation of water control procedures is accomplished in the planning and design phases of project development. Development of the water control plans should proceed with full knowledge of these planning and design studies, realizing that changed conditions may require adjustments from the operating criteria established during these studies.

### 3-3. Development of Regulation Schedules and Water Control Diagrams

#### a. Definitions

(1) A water control diagram represents a compilation of regulating criteria, guidelines, guide curves and specifications that govern basically the storage and release functions of a water resource project. The diagrams indicate pool levels and limiting rates of project releases required during various seasons of the year to meet all functional objectives of the particular project, acting separately or in combination with other projects in a system. They are usually expressed in the form of graphs and tabulations, supplemented by concise specifications, and are used to help determine regulation (release) schedules. The diagrams are sometimes called guide curves. An example of a water control diagram is shown on Figure 3-1.

(2) The water control diagrams are an important element of the water control plan in that they provide the technical guidance and specific rules of regulation that are mandated as the result of studies and the review and approval process in the planning and design phases as well as in the operational phase. However, the diagrams are only a part of the overall water control plan, which provides for adjusting project regulation on the basis of other factors that may develop in actual operation as the result of unique hydrometeorological conditions, changing water control requirements, and other factors which may influence current project regulation.

(3) Water control diagrams must be documented in a manner to assure that project regulation is accomplished in accordance with the water control plan as developed from the project regulation and system analysis studies. Guide curves are used to define the seasonal and monthly limits of storage which guide the regulation for planned purposes. The regulation is in accordance with specific operational rules that define the requirements at the project and at downstream locations in order to meet project objectives. Physical operating limits are established that define the limiting discharges and water levels at the project and in some cases at downstream locations, together with rates of change of discharge and

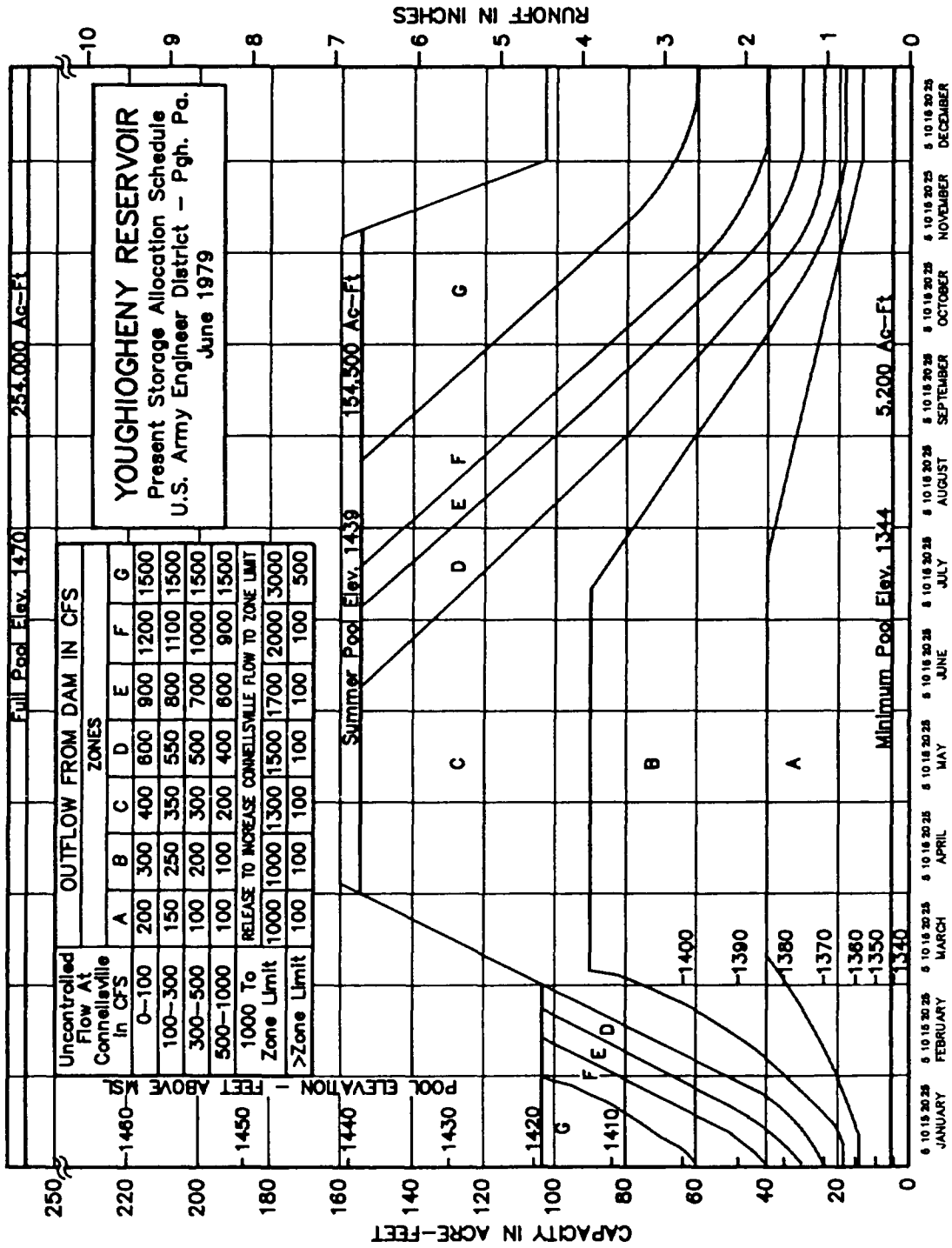

Figure 3-1

water levels. Special limitations are also applied that define limits of operation of hydraulic water control facilities (spillways, outlet works, power generation equipment, navigation locks, fish passage facilities, etc.), as they may affect the scheduling of water releases. Detailed charts and diagrams are prepared that define flood control regulation as related to hydrometeorological conditions, storage, and system regulation. Similar types of charts and guides are prepared for control of diversion and by-pass structures, hurricane or tidal barriers, and interior drainage facilities for levee projects. For those projects that include hydroelectric power, detailed instructions are set forth that define the methods for scheduling power, controlling power facilities, dispatching power in an integrated power system, limitations of operation of the power facilities, and monitoring system operation.

b. Assessments of Changed Conditions from Planning and Design Studies

(1) General. Completion of a project may occur several years after the design phase and perhaps decades after the time that the original planning studies were made. Preparation of the water control plan and the documentation of that plan in the water control manual must be undertaken based on current knowledge of conditions regarding river basin management, and the manual should be completed by the time the project becomes operational. Furthermore, for many projects that have been operational for a number of years, the water control plans and water control manuals are out-of-date, and there is a need for revising them to make them applicable to current conditions. Many of the existing water control manuals were prepared prior to current concepts of system regulation and sophisticated computerized methods of analysis. Requirements for enhancing the multi-purpose use of projects has become important, particularly with regard to environmental and public use aspects of the projects. For all of the above reasons, there is a requirement to periodically review and update the regulation procedures.

(2) Additional or New Hydrologic Data. After a project is planned or designed, additional hydrologic data from existing or new data stations become available, which in combination with previously available data, are used to re-study system regulation schedules. These data may be in the form of streamflow, rainfall, snow accumulation, or other elements which are observed routinely to help define the hydrologic character of a drainage basin. These additional records not only extend the period of record of the basic data used in the initial water control studies, but also enhance the determination of regulation criteria and basin watershed characteristics that are used in modeling procedures. The new data may also include records of significant events of extreme conditions



of flood or drought which may require modification of the water control diagram. In some cases, the additional basic data warrants a complete system hydrologic analysis for refining the derived streamflows at the projects. In any case, it is important to fully utilize all available hydrologic data when revising the water control plan.

(3) Reevaluation of Water Control Requirements

(a) In addition to the basic economic functions for which the projects were originally authorized and constructed, water management goals now include environmental and social aspects of project regulation. This conforms to public laws dealing with water related activities that were enacted after the authorization of most water control projects. These laws require inclusion of certain aspects of environmental, fish and wildlife, and recreational uses in the management of the projects or improvement of the environment of the rivers downstream through project regulation. The specific uses are determined from river basin investigations and are incorporated into the regulation plan.

(b) Besides the new requirements for including environmental and social goals in project regulation, there needs to be reevaluations of the water control criteria for meeting single or multi-purpose uses for which the projects were authorized. In the span of time between the planning or design studies and the preparation of a detailed water control plan, there may be significant changes in policy procedures or other conditions which may affect the overall regulating criteria. Therefore, a study program is carried out in connection with the development of a detailed rule/guide curve (diagram) to further refine the regulating criteria through the use of additional basic data, water management requirements, and systems analysis techniques that have become available subsequent to the planning and design studies.

(c) A periodic review of flood control regulating parameters is often required because of changed conditions with respect to seasonal downstream channel capacities, possible downstream development adjacent to the river channel, and changed economic values for flood protection. In many cases there are encroachments in the flood plain that require a reevaluation of target control elevations for flood regulation, or controlled river levels during the post flood evacuation period. The studies may be used to refine guide curves in conjunction with the additional flood data described in subparagraph (1) above. System flood control studies for multi-purpose river basin developments are made using computerized system hydrologic and reservoir regulation models.

c. Basic Flood Control Regulation

(1) Principles and Objectives

(a) The objective of regulation for flood control is to reduce flood damages to the extent possible with available facilities. The best method of attaining this objective is often difficult to determine and depends principally on the location and types of damages to be prevented, location and amount of storage capacity, flood characteristics, flood frequencies, and extent of uncontrolled drainage area.

(b) In selecting the water control diagram (and plan) to be followed, a study should be made of the results of applying various regulation schedules to the past floods of record and selected hypothetical floods. Although there is sometimes a lack of the basic data needed for a comprehensive investigation and a short period of record may be a poor index of future events, the historical record of floods is the principal source of factual data that can be relied upon for deriving and testing flood regulation schedules.

(c) In order to achieve flood control objectives, it is necessary to establish and maintain existing nondamaging channel capacities. Every effort should be made to prevent encroachments downstream of the dams which would reduce existing reservoir release rates. This can be accomplished through a joint effort between water control managers and project operators. Stored floodwater can be released up to the maximum "nondamaging" downstream channel capacities, consistent with regulation procedures, provided the releases do not exceed peak inflow into the reservoir(s). Project operators continually monitor downstream conditions and notify water control managers immediately whenever development might adversely affect regulation procedures. Water control managers may visit the area with the project operator, contact the owner, and if necessary follow through with correspondence stating that the Corps will not reduce the existing maximum nondamaging release rate to prevent flooding of the site area. Correspondence is also forwarded to appropriate local and State agencies.

(2) Classification of Flood Regulation Methods

(a) General. Although various bases exist for a classification of methods of flood control regulation, no simple analysis can be made in the more complicated situations. A general plan has been adopted, however, which classifies flood regulation by three basic methods. These methods are described in the following paragraphs.

(b) Method A. Method A regulation is based on maximum beneficial use of available storage during each flood event. This method incorporates the concept of reducing damaging stages at the locations being protected as much as possible during each flood with the currently available storage space, thus disregarding the possibility of having an appreciable portion of the flood control storage capacity filled upon the occurrence of a large subsequent flood. Where the principal damage areas are agricultural, the nondamaging stages toward which regulation is directed may be established at higher levels during the non-growing season than during the growing season when potential damages are greater. The regulation to obtain maximum benefits in minor to moderate floods can be only as successful as the ability to forecast flow conditions at the control structures and the damage centers. The use of computerized system hydrologic models for real-time streamflow and project forecasting is intended to make use of this concept of regulation and thereby maximize the flood control effectiveness of project regulation. It is pointed out, however, that there are definite limitations to the period of effective use of this type of forecasting because of the inability to reliably forecast weather related parameters (rainfall, air temperature, etc.) more than a day or two in advance. The use of computerized models enhances the ability to forecast the hydrologic conditions that affect project regulation and provide the capability of analyzing statistical probabilities of future events that would affect project regulation.

(c) Method B. This method of regulation is based on control of the project design flood. At projects where a limited amount of flood control storage is available and where the primary flood control objective is to provide protection up to a specified project design flood, flood regulation based on continual releases, up to specified amounts, is often adopted. The regulation consists of releasing water at an established rate (as may be determined by associated flood conditions and/or reservoir contents) and storing all excess inflow as long as flooding continues at specified locations. The release rates are established so that all the storage capacity is utilized during hypothetical regulation of a project design flood when operating under the adopted schedules. The schedules are then followed at all times on the assumption that the result will be the best overall regulation of floods. While this method provides considerable assurance of satisfactory regulation of major floods, less satisfactory regulation of lesser floods which occur more frequently may result in a substantial loss of benefits and complaints from downstream communities. This is particularly true at damage centers where releases can be timed so that they do not combine with damaging flows from uncontrolled areas. When benefits are desired for a considerable distance downstream, general flood characteristics and the period of time that forecasts of river

stages can be extended become increasingly important. Uncertainties which occur with the use of this method may result from being too optimistic about assumed project releases or the fact that each major flood is an individual event which may significantly alter the release patterns for control of a future flood. The effect of a possible increase in duration of downstream flooding may also be mistakenly overlooked.

(d) Method C. Method C is a combination of methods A and B, and quite often results in the most appropriate flood regulation. For instance, in protecting agricultural areas a regulation plan for maximum damage reduction during ordinary floods may be desirable during the main farming season, but may not be the most advantageous plan during the winter or severe flood season. Furthermore, it may be desirable to provide reserve (sometimes termed primary) storage to give increased assurance of protection for an important leveed area or a town which is endangered only by unusual floods. Thus, after the lower part of the storage is filled, a fixed schedule of releases would be followed to assure greater control of major floods at the expense of less regulation of moderate floods. A necessary increase in releases during emptying periods may cause difficulties by increasing the duration of flooding during flood recessions. In summary, each of the proposed methods for defining the plan for flood control regulation has inherent strengths and weaknesses, and the determination of the plan for a particular system must be based on the study effort carried out in the planning and design phase of project implementation, together with more detailed studies of project regulation performed in the operational phase. By use of computerized systems analysis models, various alternatives in methods of flood control regulation can be conveniently tested and evaluated in order to achieve the optimum regulation. Further, the experience gained in the application of these models for studying regulation plans can be applied in real-time regulation with the assurance of achieving an appropriate overall regulation.

### (3) Flood Regulation Schedule for Single Reservoir

(a) In the case of a single reservoir built for the protection of the local area immediately downstream from the dam (small uncontrolled intermediate area), the regulation schedule is a simple matter. The release schedule would consist of passing all inflow up to the value of the channel capacity and is the same for all the methods discussed in Paragraph 3-3c(2), above.

(b) If benefits are to be obtained at remote locations only (appreciable uncontrolled intermediate area), regulation under method A consists of keeping the discharge at the damage center within bankfull capacity, or a minimum release from the project (controlled

area) when above bankfull. Releases at the dam within the limits of available storage would be based on observed or forecast runoff conditions for the uncontrolled drainage area. The success of such regulation is dependent upon advantageous time relationships or the opportunity to make adequate forecasts. Releases would be based on observed and/or forecast conditions at the project site and downstream locations. A regulation schedule of method B would provide for releasing water at specified rates so that the design flood runoff could be controlled without exceeding flood storage capacity.

(c) Where primary flood control benefits are sought at downstream local and remote locations, the method of regulation and preparation of schedules becomes more complicated than for remote benefits alone, since additional restrictions on releases for successful regulation require more storage capacity. If method A is to be followed, the adequacy of the forecasts becomes of primary importance, and streamflow simulation models for forecasting river and reservoir conditions are mandatory in real-time regulation for making most efficient use of reservoir storage for flood control.

#### (4) Flood Regulation Schedules for Multireservoir Systems

(a) General regulation schedules for an integrated system of projects are usually developed first for the tributary projects operating as separate units. The adjustment of the individual regulation schedules for coordinated regulation of the various tributary and main river projects are generally based on system analyses of the basin development, design floods, and historical floods of record. The critical flood regulation plan may be determined by the occurrence of a succession of moderate floods rather than one severe flood, or an unusual flood event which is distributed in time or space differently than the normal flood occurrences. Also, in those cases where it is possible to forecast seasonal runoff volumes several months in advance (as, for example, snowmelt runoff), it is desirable to establish flood regulation criteria that considers the magnitude of expected runoff volume on a seasonal basis.

(b) Regulation based on method A is most commonly used for multireservoir systems. If channel capacities below the individual dams are limited and both local and remote benefits are obtained at locations, it is quite possible that sufficient storage will not be available for complete control during a critical basin-wide flood. Regulation based on maximum utilization of available storage probably would provide the most benefits for the system. However, to demonstrate this to be the case and to provide the necessary information for successful regulation on that basis, extensive data

on seasonal channel capacities and damage areas should be determined and periodically updated. Stream profiles for various combinations of releases from different projects must be established and the areas flooded at successive elevations of the profiles must be determined. With these data presented in the form of stage-damage curves for various reaches, controlling stages can be established so that the flood control storage may be evacuated in a reasonable length of time, minimizing damage in the basin. These factors can be evaluated with computer simulation models, and through trial and error of various methods of regulation, the optimum plan of flood regulation can be formulated.

(c) The regulation schedules depend upon forecasting both controlled and uncontrolled river stages at all of the control points. If uncontrolled damaging stages are forecast or anticipated, reservoir releases are adjusted so that the streams will just reach flood stage or some lesser stage where the uncontrolled area is large and a margin of safety for unpredictable runoff is desirable. The process may be iterated several times to test various adjustments to reservoir releases between projects in order to achieve a balanced regulation. The results of the studies are used to prepare water control diagrams which define relative amounts of storage between projects and general guides to reservoir filling or evacuation. In actual real-time regulation, the same principles are applied, but the analysis of data is based on current forecasts of streamflow and reservoir levels rather than historical data. The forecasts change from time to time because of the changing conditions of weather variables, so that adjustments to reservoir regulation are being constantly applied to make best use of the residual flood control storage at each of the projects. Also, through the process of model simulation, various extremes of weather related factors can be tested and evaluated to be sure of retaining sufficient storage space for control of unusual rainfall or snowmelt events. In summary, the guide curves (water control diagrams) provide general guides for reservoir filling and evacuation in order to meet the flood control objective of maximum beneficial use of available storage. In actual operation, the analysis afforded by real-time model simulation and forecasting provides the projections for adjusting project regulation based on current hydrometeorological conditions and estimates of future events, in order to achieve the optimum balanced regulation from the best information that is available as operating decisions are being reached.

(d) Regulation based on method B may be feasible if channel capacities below the dams are relatively large and the remote flood control benefits are obtained at a few centralized locations. Regulation schedules are based on making fixed or variable releases that depend upon existing or forecast stages at downstream control

points, and on the control of design floods at the individual projects.

(e) Normally, for major or complex river basin developments, method A or a combination of methods A and B will provide the most dependable benefits.

(5) Seasonal Variation in Flood Control Storage Requirements. Water resource systems are most commonly multipurpose. Although many Corps projects have been justified primarily for meeting flood control and navigation objectives, the other water management functions described in Chapter 2 have become increasingly important in order to achieve the full utilization of water resources. While flood control may represent the primary function for some particular projects, the capabilities of these projects to control floods can be assured along with other functional uses by seasonal allocations of project flood control storage space. The seasonal variation of the flood control requirements is determined by flood routing studies of floods of all magnitudes, distributed seasonally over the period of historic record. Synthetically derived floods may also be analyzed if the historical period of record is insufficient to provide an adequate sample of flood distributions. The seasonal guide curves (water control diagrams) that define the flood control storage space requirement are determined from these studies for each project or system of projects. These guide curves are drawn as enveloping lines of storage space required for the control of all historical floods as a function of the time of year, and they are usually drawn as straight lines on a monthly or seasonal basis. These curves represent the maximum allowable reservoir levels for which water may be stored for other multipurpose uses on a seasonal basis. For rain-fed rivers, the seasonal flood control storage reservation guide curves apply to all years, but for those rivers where snowmelt is a significant contribution to runoff, a family of guide curves representing the flood control storage reservation requirements may be derived which are based on the forecasts of anticipated seasonal runoff volume. Also, it is possible to designate flood control storage in different categories. For example, the upper portion of the flood control storage (termed primary) is assured on a completely firm basis, but the lower portion (termed secondary) is conditionally assured. The latter depends on time of year and other desired multipurpose uses that may partially utilize this portion of the storage space under certain pre-planned operation rules for regulation.

(6) Planned Control of Individual Floods. The water control plans for flood control, as described above, provide the general concepts and guidelines for flood control regulation. As noted previously, these plans are developed mostly from hindsight analysis

of historical flood events, and they are designed to achieve a generalized, optimally balanced plan of regulation for all floods, considering both minor and major floods of record as well as design floods. No two flood events are the same, and the history provided in the flood records cannot possibly represent all future events. The use of hydrologic modeling on a real-time basis provides the water control manager a means for completely analyzing the system regulation and adjusting it hourly or daily to fulfill the required flood regulation.

(7) Reservoir Evacuation. Post flood evacuation of water stored in reservoirs for rain flood regulation must be accomplished as soon as possible following the flood event. There are two general criteria for post flood evacuation: (a) releases made so that streamflows at downstream control points are at or below bankfull or non-damaging channel capacities, keeping in mind that nondamaging stages can vary seasonally in agricultural areas, or (b) releases made so that streamflows do not exceed the peak flows that occurred during the course of the flood event, where such peaks exceed bankfull capacity. The objective of release of water stored for flood control, where such floods are caused primarily by rainfall, is to provide storage for future control of subsequent flood events. In order to avoid the risk of a series of floods whose combined volume would exceed the reservoir storage capacity, it is desirable to evacuate the stored water as quickly as possible, consistent with downstream runoff conditions and weather forecasts. To meet this objective, evacuation plan (b) will provide the fastest evacuation of stored water. Release of stored water which results in above bankfull capacities prolongs the period of downstream flooding. Evacuation plan (a), on the other hand, may result in much delayed evacuation of stored water and therefore causes a greater risk of flooding from subsequent storms. In actual practice, usually a compromise between plan (a) and plan (b) is adopted, and the post flood evacuation results in river stages somewhat higher than bankfull, but lower than peak stages experienced during the flood due to the contribution from uncontrolled areas. The decisions made on adopting post flood evacuation criteria are based on flood routing studies of individual floods, damages which occur from prolonged above bankfull stages, and risks of future flood events.

d. Integration of Basic Seasonal Flood Control Guide Curves with Other Objectives

(1) General

(a) An increasing number of multipurpose projects have been constructed in connection with basin-wide development of natural resources. Therefore, development of the water control diagrams must



be compatible with all water control objectives. For some projects, storage for low-water regulation, navigation, irrigation, power production, water supply, or recreation is provided by allocating storage capacity between particular levels for specific purposes, in addition to that required for flood control, and the regulation schedules for the various uses may be independent of each other. In many reservoir systems, the multipurpose functions are compatible for joint use of the reservoir storage space, and the allocated storage space and project capabilities for all joint use functions are determined from reservoir system analysis studies. The seasonal storage allocation for flood control, as discussed in Paragraph 3-3c(5) above, provides for flood regulation in a manner similar to single-purpose flood control projects, and the seasonal guide curves defining storage capacities for all functions are depicted by charts plotted with ordinates representing storage amounts, and abscissas representing time of year.

(b) Sufficient storage capacity or water supply available from storage release and natural flow often is not sufficient to provide fully for all the desirable functions. Development of regulation schedules under these conditions results in a semidependence between purposes and requires that secondary consideration be given to other related functions when schedules are being developed for a specific purpose.

(2) Development of System Analysis Studies for All Multipurpose Uses

(a) General. The basic concepts of reservoir system analysis studies that are performed in the planning and design phase apply to the development of guide curves (water control diagrams). The emphasis of the studies in the planning and design phase is to determine the project capabilities, such as firm or secondary power potential, peaking capability, unit sizes, irrigation capabilities, water supply potential, low flow augmentation, etc., based on the historical record streamflows and proposed regulation criteria. The emphasis in the operational phase is to develop the general framework of guide curves which account for changed conditions and refinements of planning and design studies. Further, the water control plan may call for specific guide curves based on the known conditions of project regulation in the current year. These studies are also based on computerized system analysis for multiproject or multipurpose systems.

(b) Hydropower System Operation. Regulation schedules for hydropower operation cover a wide range of requirements. The general methods for evaluating power capabilities and determining power regulation are described in EM 1110-2-1701, and the application of

these methods determine the principles of regulation for a specific project. Power guide curves are derived and define the following criteria:

- the month-by-month reservoir schedule and operating limits for each project as required for system power regulation
- the plant and power system capability as related to the sale of electrical energy
- the regulation of each project in the system to meet its proportional share of the electrical power system load, in conjunction with all other water management requirements

(c) Irrigation, Navigation, Fish and Wildlife, Water Quality, M&I, and Other Functional Use Requirements. As is the case for integrating basic seasonal flood control reservoir guide curves (water control diagrams) with power operations, the water supply requirements for irrigation, navigation, fish and wildlife, water quality, M&I and other functional uses may be integrated with basic flood control guide curves. Inasmuch as the water supply functions could conflict conceptually with flood control for the assured use of reservoir storage space, there must be definite guide curves, which define the upper and lower limits of reservoir regulation for these water supply functions as well as for flood control. These limits are usually defined as seasonally variable guide curves, which are inviolate in actual operation except as necessary to meet the specific functional goals set forth in the planning and design phase. The definition of these guide curves becomes the means for balancing the relative use of storage space in reservoirs when conflicting multipurpose functions occur and for achieving a compromise as may be necessary to meet the project's functional commitments. The functional objectives of project regulation to provide water supply and methods for analyzing the water control plans to account for them have been previously described. These basic requirements are incorporated in the water systems analysis operational studies as discussed into this section, and the refinements in project regulation are incorporated into the seasonal guide curves. The guide curves are usually generalized for application to all years and would thereby account for future variable hydrologic and operating conditions anticipated from the system studies. In some cases, the guide curves are developed individually on a year-to-year basis in order to account for specific operating criteria as defined for that particular year.

(d) Environmental, Social and Aesthetic Requirements. For many river systems in the United States, the awareness of environmental, social and aesthetic values has focused on the importance of these

aspects of project regulation. Some of the requirements are set forth in Federal legislation, while others result from local, state or regional input that may represent the desires of particular interest groups or the general public in preserving or enhancing these values. There is a wide range of desires that may be considered in connection with environmental, social and aesthetic considerations, some of which are easily accommodated in the general concepts of regulation for other purposes. Other desires may be almost completely infeasible or impractical from an economic point of view, considering the functional uses for which the project was authorized and constructed. The judgment on which to base consideration of these requirements or desires must be made with full knowledge of the history of project development, legislative actions, project justification, and the planning of project utilization. Various alternatives for meeting environmental and social goals should be tested in connection with water control plan studies in order to determine their effects on each of the water control functions, and recommendations for change should be made based on the judgment and analyses of the results of the studies. The regulation schedules which include environmental, social, or aesthetic values may be in the form of generalized relationships and rules which apply to all years of future regulation. Others are specifically developed for a particular year or season's and are changeable from year-to-year. The detailed regulation schedules may be in the form of: (1) guide curves of storage required on a seasonal basis in conjunction with other functional water uses; (2) minimum project releases which may vary seasonally or as a function of water in storage which is usable for downstream release and surplus to other needs; (3) rates of change of discharge or water surface elevation, either at the project or at a downstream control point; or (4) special short-term releases for a particular environmental or aesthetic need.

(3) Solutions of Systems Analysis to Determine Optimal and Balanced Regulation. The use of reservoir systems analysis techniques, discussed in Paragraph 3-3d(2), provides the basic means for developing and testing the detailed regulation schedules and water control diagrams in general. The studies may be used to simulate the regulation of projects on a foresight rather than hindsight basis by using derived or synthetic forecasts of project inflows. If it is not hydrologically feasible to forecast inflows, the observed conditions of runoff may be used, with the assumption that no reference is made to future hydrologic events in determining the regulation within the studies. Various assumptions for regulation criteria of each of the elements discussed in Paragraph 3-3d(2) can be individually tested in conjunction with all other elements, and the optimum and balanced regulation criteria and schedules may be derived by repetitive solutions of the simulation.

### 3-4. Testing Water Control Plans

a. General. Water control diagrams are usually developed on a "hindsight" basis, using historical streamflow data, and with full or partial knowledge of runoff events that may be used in adjusting the criteria to best achieve the water management objectives. The schedules may have been derived on only a portion of the historical sequence of streamflows which had been selected as the most critical sequences of either high- or low-flow conditions that would control the water management criteria for flood control and/or water supply functions. In actual operation, the runoff sequences will never duplicate those of the historical record. Therefore, it is desirable to test the guide curves and other criteria on the water control diagram using independent data, in a manner similar to actual operation. This concept applies to both flood regulation as well as regulation to meet water supply utilization for hydroelectric power, irrigation, navigation, and other water uses. The data used for input to the test regulations may be historical data, other than those used in developing the schedules, or it may be independently derived by statistical stochastic methods or from hypothetically derived streamflows, design floods, etc.

b. Short-Term Flood Control Analysis. Although the flood control regulation criteria are usually developed from studies of the maximum floods of record, it is desirable to test the criteria on all magnitudes of floods, including the infrequent design floods as well as more frequent floods of lesser magnitude. For this reason, a program should be established for making simulations of streamflow and project regulation for short-term analysis, using daily or shorter time period streamflows as may be appropriate, for testing the flood regulation criteria on independent data which encompasses the entire spectrum of flood conditions. Procedures using computer models simulate both natural and regulated streamflows at all inflow stations, projects and downstream control points in the system and perform the necessary routings through the structures and channel for modeling a complete river system regulation. Thus, these models may be used to simulate forecasts of streamflow and project conditions in real-time, or may be used to simulate system regulation using observed or derived streamflows.

#### c. Long-Term Water Utilization Analysis

(1) Testing regulation guide curves and other criteria on the water control diagram for long-term water utilization should also be performed for those projects or systems which involve hydroelectric power, irrigation, navigation, M&I, water quality, low-flow

augmentation, or other water uses. The tests are performed using system analysis techniques, and generally use mean monthly streamflow data and monthly regulation criteria. The system regulation should usually be tested on data independent from those used in establishing the regulation criteria. For those projects where the water control plan uses forecasts of seasonal runoff volume as one of the parameters, the simulations should be based on forecasts of runoff volumes which have been derived from available hydrometeorological data. The simulations developed from these tests will reflect the errors in forecasting seasonal runoff volume and accordingly provide a realistic appraisal of system regulation under actual operating conditions.

(2) Testing regulation criteria as described above provides the means for evaluating the effectiveness of the water control plans under actual operating conditions and for refining the water control diagram into a final document that can be used on a daily basis. Any serious deficiencies in regulation that are detected in the testing program should be dealt with by reformulating the plans.

3-5. Winter Navigation. The water control plan needs to include management of ice to minimize adverse impact on winter navigation. This plan will cover the river system and include the following:

- ice and related hydrometeorological data collection and monitoring
- ice forecasting
- communication system (between projects, water control offices, towing industry, and Coast Guard)
- regulation plan for river system
- decision matrix on when ice conditions are too severe to maintain project operation for navigation

This plan must consider all project purposes such as navigation, water quality, flood control, hydropower, recreation, and environmental protection.

### 3-6. Revision of Water Control Plans

a. General. The water control plans and manuals for many projects that have been in operation for several years are out of date, and there is a need to revise them to be applicable to current

conditions. Also, delays in revision often result from budget and manpower constraints, and the high proficiency of water control managers in performing their duties; i.e., management often decides it can get by without updating the documents and, consequently, assigns this task a very low priority. Continual vigilance by responsible water control managers is required to overcome this unfortunate dilemma. Many of the existing water control manuals were prepared prior to current concepts of system regulation and sophisticated computerized methods of analysis. Requirements for enhancing the multipurpose use of projects has become important, particularly with regard to environmental and public use aspects of the projects. For these reasons and others that follow, there is a need to periodically review and update the regulation criteria and procedures.

b. Additional or New Hydrologic Data. In some cases it is important to fully utilize all available hydrologic data when revising the water control plan, especially when the period of record available for design was relatively short. After a project is designed or completed, additional hydrologic data from existing or new water data stations become available, which in combination with previously available data, are used to restudy system regulation schedules. The data may be in the form of streamflow, rainfall, snow accumulation, or other elements which are observed routinely to help define the hydrologic character of a drainage basin. These additional records not only extend the period of record of the basic data used in the initial water control studies, but also aid the revision of regulation criteria and basin watershed characteristics that are used in modeling procedures. The new data may also include records of significant events of extreme conditions of flood or drought which may require modification of the water control diagram. In some cases, the additional basic data warrants a complete system hydrologic analysis for refining the derived streamflows at the projects.

c. Reevaluation of Water Control Requirements and Objectives

(1) In addition to the basic economic functions for which the projects were originally authorized and constructed, water management goals now include environmental and social aspects of project regulation. This conforms to public laws dealing with water related activities that were enacted after the authorization of most water control projects. These laws require inclusion of certain aspects of environmental, fish and wildlife, and recreational uses in the management of the projects, or improvement of the environment of the rivers downstream through project regulation. The specific uses are determined from river basin investigations and are incorporated into the water control plan.

(2) In addition to the new requirements for including environmental and social goals in project regulation, there needs to be reevaluations of the water control criteria for meeting single or multipurpose uses for which the projects were authorized. Conditions may change. For example, a periodic review of flood control regulating parameters is sometimes required because of changed conditions with respect to seasonal downstream channel capacities, possible downstream development adjacent to the river channel, and changed economic values for flood protection. In many cases there are encroachments in the flood plain that require reevaluation of target control elevations for flood regulation, or controlled river levels during the post flood evacuation period. The studies may be used to refine guide curves and regulation schedules on water control diagrams, in conjunction with the additional flood data described above. System water management studies for multipurpose project and river basin development may now be made using computerized hydrologic and water control models.

d. Updating or Modifying Water Quality Control Procedures and Plans

(1) If the appropriate techniques are properly implemented, water quality conditions associated with initial impoundment and the first several years of operation will be anticipated. In most cases, unusual but predictable phenomena will occur for the first year or so after initial fill. For example, in stratified reservoirs, inundated vegetation will generate high concentrations of hydrogen sulfide which will flush out of the project by the second or third year of operation.

(2) The fact that changes will occur in terms of water quality and operating procedures must be anticipated. Land use changes, extreme or unusual weather events, etc., may induce abrupt or long-term changes in water quality conditions. Operating procedures may also be modified for other reasons such as water user needs or changes in management objectives. Operating experience may suggest alternative procedures or indicate need for major modifications.

(3) Monitoring and surveillance activities, which provide data for operating guidance, usually include watershed surveillance, inflow and discharge monitoring and water quality profiles in the reservoir. These actions also identify long-term trends as well as abrupt changes. In some instances, special studies of reservoir conditions will be required in order to develop guidance for modifying operating procedures or, perhaps, control structures. Such studies may be relatively simple in time and scope or may require

math modeling, reservoir system analysis or physical model applications.

(4) The above activities, information and data will also provide input for updating water control plans and manuals. Water quality data summaries will be included in project descriptions and used to identify changes in conditions. The operating experience will be documented in terms of success and/or failure in meeting water quality objectives. Results of studies will be documented particularly when used as a basis for modifying operating procedures.

e. Constraints on Water Control Plans. The physical size and capacity of water control structures, and other conditions that exist at the time of project design, certainly impose limitations and boundaries on water control capabilities, but are not considered to be constraints. A constraint is a condition that arises subsequent to project design that prevents (or is allowed to prevent) the achievement of a water control objective. Constraints may result from physical, social or economic impacts on residual, agricultural, industrial or environmental areas that are affected by the water control capabilities of a project. The purpose of the discussion here is to acknowledge some of the kinds of constraints that come to bear on water control projects. Other than possible compensating changes in water control procedures, however, their resolution is beyond the scope of this EM.

(1) Constraints due to Incomplete Project Development

- downstream channel capacity used for design is not provided, which may have been based on clearing and snagging, realignment, enlargement, dredging, or levee construction.
- inadequate, vague or complete lack of easement acquisition that prevents full use of storage space, or flowage downstream of water control structures.

(2) Impacts (Constraints) Beyond the Scope of Design

- encroachments in the flood plain downstream and in areas upstream of water control structures impose restrictions on utilization of authorized storage space and release schedules.
- attenuation of flows by control structures often permits and encourages low lying lands that were frequently flooded before project development, to be cleared and used, which reduces the nondamaging channel capacity.



- near bankfull flows and near constant (of higher than normal) pool levels for prolonged periods may increase erosion, requiring reduced or fluctuating releases and a change in pool levels.
- seasonal drawdown may be restricted due to development of mud flats in the reservoir area.
- the time of inundation of roads and railroads may be highly restrictive on transportation and prolonged inundation of boat ramps, docks and marinas may severely hamper recreation activities.
- the time required to notify the public may delay implementation of a release schedule during flood emergencies.
- earthquake potential or embankment boils may restrict or prevent use of authorized storage capacities, or structural deterioration may require reduced discharge capacities to ensure project integrity.
- structural rehabilitation may require significant changes in release schedules temporarily.
- point or non-point pollution and stratification can degrade water quality and render it unsuitable for fish and wildlife, water supply, and other conservation purposes.
- meteorological forecasts that are unauthorized (non-Federal) for Corps use may be inaccurate and may mislead the public re potential impacts on Corps projects.
- conservatively high (intentionally inaccurate) hydrologic forecasts issued by the NWS can mislead the public, our common constituency, causing the public to question Corps releases and to seek water control action that is inappropriate.
- frequency of filling and runoff volume may increase at impoundments over pre-project conditions, requiring higher release rates from reservoirs and additional pumping capacity at local protection (interior drainage) projects.
- an extreme low flow event may occur that is more severe than the hydrologic record when the project was designed, which detrimentally impacts conservation purposes by restricting releases for water quality, water supply, hydropower, etc.



Figure 3-2 Bonneville Lock and Dam Columbia River Oregon.

## CHAPTER 4

### OPERATIONAL CHARACTERISTICS OF WATER CONTROL FACILITIES

#### 4-1. General Considerations

a. Background Information. The water manager must have full knowledge of the operational characteristics of water control facilities insofar as they relate to the problems of control and management in the achievement of water management goals. This requirement covers a broad spectrum of knowledge regarding the types of design, hydraulic characteristics and methods of operation of these facilities.

b. Types of Facilities. The water control facilities most commonly used at projects for the control of water flow are (1) spillways and (2) outlet works consisting of sluices, conduits or tunnels. These facilities are usually gated, but under some circumstances they are ungated. Furthermore, there are several other types of water control facilities which are constructed for specialized functions and have an important relationship to the regulation of streamflow, water level, and the conditions of water quality at the project or at downstream locations. These include hydroelectric power units, navigation locks, fish passage facilities, sluiceways for passing trash or ice, interior drainage facilities, hurricane and tidal barriers, bypass structures, and selective withdrawal facilities for outlets or power turbines. The specific design limitations and methods of operation must be accounted for in the project regulation criteria, as well as in scheduling of water releases. This chapter will summarize the types and design of water passage facilities at projects and identify requirements, methods, capabilities and limitations in utilizing each of the types of water passage facilities to meet the water management goals.

c. Design Criteria. Guidance in the design of hydraulic features at Corps projects is contained in Engineering Manuals prepared by HQUSACE. Specific reference is made to those manuals dealing with the design of hydraulic features, as listed in Chapter 1. In the design phase of project development, specific design of hydraulic structures is documented in the feature design memoranda. These design documents include information pertaining to the functional design criteria, design capacities, operating restrictions, control equipment, and methods of operation. These criteria are arrived at in coordination between the design branch and the water management, hydrology or other appropriate branch dealing with water regulation activities during the design phase. After a project becomes operational, experience gained under actual operating

conditions may provide additional information regarding capacities and operating limits of these facilities.

d. Terminology. The following definition of terms have been adopted for describing flow passage facilities at dams and conform with general design practice in the Corps:

- Spillways. Gated or ungated structures used to release floodwater which normally cannot be passed by other water passage facilities at the dam; primarily to prevent overtopping of the dam.
- Outlet Works. Project outlet works or conduits required for passing flows to meet project functions or controlling reservoir levels.

#### 4-2. Spillways

a. General. There are particular operating problems that are dealt with in the design of spillways and appurtenant facilities which are of significance to the water control manager. These include:

- Cavitation
- Erosion
- Vibration of gates
- Gate operation with regard to manual, remote, or automatic operating mechanisms, incremental openings, operation under partial gate openings, and selective spillway gate operation to achieve desired flow patterns for hydraulic considerations or for improving fish passage.
- Gate operation with regard to the functional use of storage, particularly with regard to control of floods and the use of surcharge storage.
- Problems related to passing or handling debris.
- Problems related to ice formation in the reservoir, ice flows, and the effect of ice or subfreezing temperatures on gate operation.
- Problems related to the passage of upstream and downstream migrant fish.

EM 1110-2-1603 describes the technical aspects of design for the hydraulic features of spillways, spillway chutes, energy dissipators, and spillway gates. The various types of spillways normally encountered at dams and reservoirs are described in the following subparagraphs.

(1) Concrete Overflow Spillways. Concrete gravity dams usually have overflow spillways. This type of spillway may be constructed for either high or low dams, and the cross-sectional shape is characterized by an ogee section which conducts the water flow from the headwater to the tailwater at the dam. The energy of the falling water is dissipated in a stilling basin or by some other means in which the erosive power of the high velocity water flow is safely expended.

(2) Chute Spillways. The chute spillway is commonly used for earth dams and is located in the abutment or a saddle some distance from the dam. A chute spillway consists of a spillway crest, a chute normally constructed as a concrete-lined channel that conducts the water from the headwater to the energy dissipator, and an energy dissipation facility that provides for the safe passage of high velocity flows in the tailwater area some distance below the dam. In some cases the chute may be in an unlined channel, and the energy dissipation may be designed to occur in erodible material.

(3) Other Spillway Inlets. Upstream inlets are sometimes necessary for dams in narrow canyons or may prove economical at other sites where the design discharge requirements are relatively small. The spillway inlet structure may be either a side channel or a morning glory spillway. The upstream inlet usually discharges into a tunnel driven through the abutment. Side channel spillways for relatively low dams have been used in conjunction with a chute through an open cut in the abutment.

b. Energy Dissipators. Energy dissipation is probably the most important technical hydraulic problem with regard to the design of spillways and outlet works. Energy dissipators are designed to minimize damage resulting from high velocity flows that are experienced either in the stilling basin or in the areas immediately downstream from the dam. The energy that must be dissipated is extremely high for spillways constructed at major dams, particularly for those with high head. For example, for dams whose hydraulic head is approximately 100 feet, between 5,000 and 20,000 horsepower per foot of spillway width must be dissipated, depending upon the depth of water flowing over the spillway crest. In general, there are four possible causes of damage to energy dissipators:

- Cavitation, resulting from high velocities and negative pressures downstream from baffle blocks, lateral steps, or other projections in the stilling basin.
- Abrasion, caused by the presence of gravel, boulders, or other hard materials in the stilling basin or roller bucket, which will erode the surfaces and also may enhance the damage by cavitation.
- Pulsating pressures, which may cause failure or deformation of sidewalls or splinter walls constructed in or adjacent to stilling basins.
- Erosion and scour of the area immediately downstream from the energy dissipator which results in undermining.

(1) Types. Three basic types of energy dissipators have been used. The most commonly used have been stilling basins employing the hydraulic jump to dissipate energy. The roller bucket has been used at some projects where substantial tailwater is available, and the energy is dissipated immediately downstream from the bucket in the area of turbulent flows created by the rolling action. The flip bucket (or ski jump spillway) throws the jet of water some considerable distance downstream from the dam, so any riverbed erosion does not occur close to the downstream toe of the dam or terminal spillway structure. Flip buckets are generally used where the downstream channel is located in sound rock, where water depths for the impinging flow are relatively great, or where erosion in the stream bed would not endanger the dam or appurtenant structures.

(2) Operation. In the operation of prototype facilities for energy dissipation, performance of the facilities may be of utmost importance to the water control manager. If significant damage occurs in the stilling basin, the basin may be inoperative or only partially operative for a period of repair. The scheduling of repairs must maintain the safety of the structure, particularly with regard to extreme flows that must be provided for during the repair period. Also, the scheduling must consider the normal flow requirements that may be impacted by the repair, and such considerations may require adjustments to the normal operating schedules. The use of any other facilities that may cause damage to the energy dissipators should be minimized. In addition, consideration should be given to minimizing adverse effects that may result from flow conditions in the stilling basin on fish migration, nitrogen supersaturation, navigation, and public safety.

c. Spillway Gates. Spillway crest gates are used to control the spillway discharge in accordance with specified conditions of

operation to achieve predetermined water regulation goals, primarily for flood control, but they may also be used for controlling water flows in connection with other water use requirements. The fact that gated spillways provide the ability to make sizeable releases, perhaps well in excess of the reservoir inflow, requires special care in scheduling gate releases and assuring that the outflows are controlled to predetermined standards of operation. There are three main types of spillway gates commonly used and these are described as follows:

(1) Tainter (Radial) Gates. Many major projects utilize tainter gates with a design head of 30 to 60 feet and a width of 30 to 50 feet. Tainter gates are not designed for overtopping, and they are usually designed for 2 feet of freeboard with maximum operating pool when the gates are closed. The gate seal on the spillway crest is usually located downstream from the crest axis. This assures that the water jet issuing from under the gate has a downward direction, resulting in positive pressures immediately downstream from the gate. Tainter gate side arms which carry the load to the trunnions, eliminate the need for gate slots. Spillway gates have been known to vibrate for various reasons, such as bottom hip and/or spill design. Spillway gates can not always be tested upon completion because of lack of water so operators should be aware of the potential for vibration.

(2) Vertical Lift Gates. Vertical lift gates are most commonly used on low head dams. The split-leaf option for vertical lift gates allows the top portion to be hoisted independently of the low portion. The hydrostatic load of a vertical lift gate is carried to the structure through bearing plates in the gate slots rather than through a trunnion as is the case with the tainter gate. The type of side bearing characterizes the gate as a wheel gate, tractor gate, or Stoney gate.

(3) Drum Gates. Drum gates, although seldom used at Corps of Engineers projects, have been commonly used at U.S. Bureau of Reclamation dams (e.g., Grand Coulee Dam). A drum gate is designed to float on water in a chamber located in the spillway crest. The water which is being spilled flows over the top of the drum onto the ogee section of the spillway. The drum is raised by hydrostatic pressure and its range of operation is from its lower limit where the top of the drum is at the spillway crest elevation (fully open) to its upper limit where the top of the drum corresponds to full pool level (fully closed).

d. Spillway Capacity and Discharge Ratings. Spillways are sized in accordance with criteria and methods for computing extreme floods contained in EM 1110-2-1405 and other instructions and

publications issued by HQUSACE, pertaining to spillway design flood criteria for various types of dams. The details concerning the methods for determining the ratings for spillways are presented in EM 1110-2-1603.

e. Operation of Spillway Gates. Spillway gate operation is based on prescribed discharges set forth in reservoir regulation schedules. In some cases (run-of-river power-navigation projects, for example), the spillway gates are operated to maintain a particular water level. Some gate control mechanisms have a safety override feature which prevents opening the gates more than a prescribed increment without an intentional restarting of the gate operating mechanism. Spillway gate control equipment is usually located near the gate, but at some projects, the gates may be operated remotely from the project control room, which may be at site or at another location. At a few projects, spillway gates may be operated by automatic control, based on reservoir levels or hydroelectric power load.

#### 4-3. Outlet Works

a. Functional Requirements. The following paragraphs, extracted in part from EM 1110-2-1602, briefly summarize functional requirements and related design considerations for outlet works used for regulating streamflows at dams and reservoirs. This summary provides a general background of the principle elements and engineering considerations in the design and use of outlet works in the management of water control systems.

(1) Flood Control. Flood control outlets are designed for relatively large capacities where close regulation of flow is less important than are other requirements. Although control of the outflow by gates is usually provided, the conduits may be ungated, in which case the reservoir is low or empty except in time of flood. Special provisions must be made for design of gates, water passages, and energy dissipator at projects where large discharges must be released under high heads.

(2) Conservation. Reservoirs that store water for subsequent release to downstream navigation, irrigation, and water supply, usually discharge at lower capacity than flood control reservoirs, but the need for close regulation of the flow is more important. Where water quality is of concern, multiple intakes and control mechanisms are often installed to assure reliability, to enable the water to be drawn from any selected reservoir level to obtain water of a desired temperature, and/or to draw from a stratum relatively free from silt or algae or other undesirable contents. Ease of



maintenance and repair without interruption of service is of primary importance.

(3) Power. Outlet facilities required for operation of hydroelectric power are discussed in Engineering Manual 1110-2-1701. Power tunnels or penstocks may be used for flood control and other water passage requirements.

(4) Diversion. Flood control outlets may be used for total or partial diversion of the stream from its natural channel during construction of the dam.

(5) Drawdown. Requirements for low-level discharge facilities for drawdown of impoundments are discussed in ER 1110-2-50.

b. Sluices for Concrete Dams. Sluices constructed in concrete dams may be rectangular, circular, or oblong. Those designed primarily for flood control releases may be sized to provide a relatively large number of individual sluices, each being in the general range of 4 to 6 feet wide and 6 to 10 feet high. The flow through each sluice is controlled by individual gates or valves, thereby providing a finer degree of control than from a smaller number of sluices of larger cross-sectional area. Sluice intakes are provided with trashracks where debris protection is required.

c. Gate Passageways. The gate section is that portion of the sluice in which the gates operate. It is specially designed to eliminate or reduce the effects of cavitation as much as possible. Particularly when high head gates are operated under partial opening, they may be subject to severe cavitation and vibration and have a high air demand. Air vents are provided and are specifically designed to reduce cavitation for control valves that do not discharge into the atmosphere. Normally, two gates in tandem are provided for each sluice to assure flow regulation if one becomes inoperative. Emergency gates shall be provided for each service gate passage so that if a service gate is inoperative in any position, closure of the gate passage can be made. Bulkheads which allow inspection and maintenance of the upstream gate frame and seal are also provided for each gate passage. Gate passages of circular cross section are designed when necessary to accommodate circular gates or valves, such as knife or ring-follower gates or butterfly, fixed cone, or needle valves. Rectangular gate passages are used for slide, tainter, and tractor or wheel-type gates.

d. Control Works. Control works for sluices are classified as gates and control valves. Vertical lift gates may be either slide, fixed wheel or tractor gates, which are operated by hydraulic cylinders, cables, or rigid stem connection to the hoist mechanism.

Hydraulically operated gates are preferred for high heads and for long periods of operation. Tainter gates are also used as service gates operating at high heads. Control valves, including knife gate, needle-type, fixed-cone, and various commercial valves, have been used for flow control for discharging water freely into the air or into an enlarged, well-vented conduit. Commonly used valves include butterfly, needle-type (hollow jet), fixed-cone, and commercially available valves for small conduits.

e. Operation of the Control Works. The operation of control valves or service gates may be based on manual, automatic, or remote control. In a few cases the outlet works are under automatic control, and the outlet works are controlled by water level sensors. Vertical lift gates are usually manually operated by use of lifting mechanisms, which may be "dogged" at fixed increments of elevation to approximate a particular gate setting. Tainter or slide gates that are driven by hydraulic or electrical hoists may be controlled either at the site of the gate machinery or, in some cases, remotely from the project control room. The gate control mechanisms may have an override feature that limits the opening increment to a pre-established small value. The operation of the gate then requires successive iterations to exceed the pre-set incremental opening. Special problems may arise with the operation of the outlet works, such as ice, trash, excessive vibration, erosion or cavitation. Such problems must be resolved to assure the reliable operation to meet the water management goals and also to maintain the integrity of the project facilities.

f. Discharges. Discharge is normally determined from theoretically derived discharge ratings, however, metering devices for monitoring flow through conduits may be provided under unusual circumstances, especially when accuracy of flow determination is important for regulation of outflows.

g. Outlet Facilities for Embankment Dams. Outlet facilities for embankment dams are provided through use of conduits and tunnels. The intake structure may be gated tower, multilevel, uncontrolled two-way riser, and/or a combination of these. The control structure may be either in the intake tower or in a central control shaft. A combined intake and gate structure is most commonly used, but underground control structures may be more economical and offer certain other advantages. Gate passage and control gate designs for sluices also apply to conduits through embankment dams. Special problems involved in the operation of outlet works through embankment dams include:

- Head loss, boundary pressures, and vortices in the approach of the intake structure
- Protection from debris by use of trashracks
- Hydraulic loads for vertical lift gates
- Gate "catapulting", resulting from water pressure building up on the downstream side of the intake gate during the process of watering up the space between the service and emergency gates
- Vibration and resonance of cable supported gates
- Transitions and exit conditions of the conduit or outlet tunnel

h. Low-Flow Facilities. The operation of large gates at small openings (less than 0.5 ft) is not recommended because of the increased potential for cavitation downstream from the gate slot. Projects which require low-flow releases are designed with low-flow bypass culverts, center pier culverts, multilevel wet well facilities, or a low-flow gate incorporated into the service gate. Where a single tunnel is used and other water release facility is not available, a bypass is desirable to keep water in the river during periods of repair.

i. Selective Withdrawal Systems. Selective withdrawal systems may be provided to draw water from specified elevations in the reservoir. These structures fall into three general types: (1) inclined intake on a sloping embankment; (2) freestanding intake tower, usually incorporated into the flood control outlet facilities of embankment dams; and (3) face-of-dam intake, constructed as an integral part of the vertical upstream face of a concrete dam. Types (2) and (3) predominate at Corps of Engineers projects. Selective withdrawal structures include: (1) inlets and collection wells, (2) control gate passages, and (3) exit passages. Inlet ports are designed to be operated fully open or closed, and the total flow is regulated by a downstream control gate or power unit. The inlet ports are operated manually with gate hoists or other operating equipment. Some existing, successful, single-well systems allow for blending of water withdrawals from more than one level. An inlet port that is not totally submerged can be operated as an inlet weir, and the combined operation of the weir and downstream control can be balanced to provide the desired flow characteristics. Collection wells are provided for directing the flow of water from the intake system to the outflow passages. In dual wet well systems blending of flows for water quality purposes should be done by blending flows

from separate wet wells. Each wet well should have individual flow control, and inlets at only one elevation should be open in each wet well. Submerged weirs upstream of outlet works can be used to prevent withdrawal of bottom waters from reservoirs by flood control conduits and penstocks. Conversely it may be desirable to withdraw bottom waters as rapidly as possible after a flood; for example, when turbidity is a consideration. In general, all water quality control devices for selective withdrawal are individually designed to meet the particular project requirements, and the regulation of these facilities must be based on the experience gained during the operational phase.

j. Energy Dissipation. Energy dissipation for all types of outlet works constructed at dams is an important feature of the hydraulic design of the water control systems. A hydraulic-jump type stilling basin is most frequently used for energy dissipation from conduits or sluices. The stilling basin may also incorporate the energy dissipation requirements for spillway discharges. Stilling basins are generally but not always designed for optimum energy dissipation of controlled flows equal to the capacity of the outlet works. The design of the stilling basin requires a detailed hydraulic analysis, which usually includes hydraulic model studies. In summary, the energy dissipation effected by the use of stilling basins or other methods is an important consideration in the overall management of water releases from projects, and the effectiveness of the system may have particular significance to the water manager.

k. Summary. The water control manager should have general knowledge of the hydraulic design of the outlet works in order to evaluate special operating problems that may arise. Specific knowledge of the detailed design for projects is also required in order to fully understand design limitations, unusual operating problems, discharge characteristics and other factors that may influence the use of these facilities on a day-to-day basis. This summary of outlet work design is only a general description of outlet facilities and design requirements. The reader is referred to EM 1110-2-1602 for a more complete description of the methods of design for outlet works and to the individual feature design memoranda for a description of the design of outlet works for specific projects.

#### 4-4. Flood Control Operation

a. Project Outflows. Chapter 3 presents the basic methods for developing reservoir regulation schedules for flood regulation. The project outflows to meet the flood control schedules are usually obtained through use of either the spillways or outlet works, but the

total project outflow requirement may be met by combined use of these facilities and the outflows from hydroelectric power units for those projects with hydropower facilities. The regulating outlets are sized to provide the pre-flood or post-flood evacuation of reservoir storage, as well as the pre-flood requirements for maintaining the storage space in the reservoir prior to the time that water is stored in the interest of downstream flood regulation. Also, during the flood regulation period project outflows must be frequently specified in order to achieve the downstream flood control objectives. In general, the outlet works are designed to be used for controlling releases during the pre-flood period and the actual period of flood regulation. The spillway may be utilized when the reservoir approaches full pool level or in connection with the need for induced surcharge storage in the reservoir. Thus, the outlet works and the spillway provide the principal means for regulating the reservoir levels to achieve the downstream flood control objectives.

b. Controlling and Monitoring Outlet and Spillway Gate Regulation. The water control manager issues flood regulation schedules and operating instructions to the projects. These instructions may include direction as to total discharge, gate settings, rates of change and selection of where outflow is to be released. The project operational data reports (described in Chapter 5) inform the water control manager of the actual operation of the facilities in the form of discharge amounts, gate settings, and reservoir levels for monitoring the reservoir regulation. For some projects, automatic sensors at gate openings provide continuous reservoir regulation data to the control center. The water control manager must be informed of any problems which may involve the operation of the outlet works and the spillway. Any adjustments to reservoir regulation that may result from restrictions in the use of the outlet or spillway facilities should be coordinated between the project operator and the water control manager.

c. Combined Use of Outlet Works and Spillways. One technical hydraulic problem related to the flood control regulation of reservoirs is the combined use of outlet works and spillways to pass the required outflows during flood periods. Many projects base the spillway design discharge capacity (usually the probable maximum flood) on the combined use of the full capacity of the spillway and outlet works. In some cases, this capacity includes a portion of the capacity of hydropower units that can be expected to be operable at the time of the flood. Combined use of outlets and spillways depends on evaluations of the hydraulic and structural designs at the particular project. These evaluations include:

- The flow characteristics of the spillway and outlet works with regard to symmetry of flow in the spillway or outlet channel;
- The allowable head on the outlet works;
- Cavitation in the outlet works or spillway;
- Back pressure on the outlet tunnel resulting from high tailwater;
- Tailwater conditions which affect the performance of the stilling basin;
- Gate operation with partial gate openings for both outlet and spillway gates;
- The effect of the discharges on the flow patterns in the stilling basin;
- Erosion or damage in lined or unlined channels which conduct the water to the river below the dam;
- The interrelationships among flow conditions affecting other facilities such as fish passage, navigation channels, revetments, etc.

Some projects are designed for rare use of spillways. This would be the case if the outlet channel to the spillway is unlined, and the use of the spillway would result in erosion in the spillway and the downstream river channel. In such cases, every effort should be made to utilize the full capacity of the outlet works in order to minimize the probability and/or the magnitude and duration of flows passing over the spillway. The preceding discussion highlights problems related to the combined use of the outlet works and spillways. Each project has its own particular design characteristics, and the project should be operated in a manner to minimize damage to the project structures based on knowledge of design, experience gained from project operation and anticipated flood regulation requirements. This information should be incorporated into the project water control manuals, and periodically updated to reflect the experience gained from actual operation.

d. Free-Flow Operation of Gated Spillways which Control Large Natural Lakes. Some projects are constructed with dams and gate controlled spillways to regulate the water surface elevations and outflows of large natural lakes. Such projects may also have at-site hydroelectric power installations, navigation locks, or other water

control facilities. Usually, the operating range of the reservoir levels is limited to relatively modest amounts; that is, the difference in elevation between minimum and normal full pool levels is normally only 15 to 25 feet. The primary purpose of these projects is to supply water for downstream use on a seasonal basis for hydropower production, irrigation, or water supply, utilizing the storage that would be approximately equal to the uncontrolled natural storage in the lake. The mode of operation for seasonal storage regulation for these projects is to fill the storage space during the high-flow season to the normal full pool level, hold the water in storage until needed for at-site or downstream flow regulation, and then use the stored water to augment streamflows during the low-water period. Projects of this type utilize spillways which are designed to provide approximately the equivalent capacity of the natural lake outlet. The spillway discharge may be augmented by outflows through power units.

#### 4-5. Induced Surcharge Storage

a. General Principles. Reservoirs controlled by dams with gated spillways present special operating problems during flood regulation. Particularly for large floods, the use of spillway gates (sometimes in combination with the outlet works) must be carefully scheduled to minimize downstream flood flows to the extent possible by optimum use of the storage capacity. Also, when circumstances require that the spillway must be utilized, the transition from normal low outflows to significantly higher outflows resulting from the use of the spillway must be performed gradually so as not to constitute a major hazard to downstream interests. The operation of spillway gates during floods must be regulated to compensate for potential changes to project inflow hydrographs which can result from:

- lost valley storage
- changed river channel hydraulic properties
- synchronization of tributary inflows
- rain falling directly on the reservoir surface areas

b. Surcharge Storage for Free-Flow Ungated Spillways. The degree of control afforded by the free-flow operation of a spillway is determined by reservoir storage routing of unsteady (nonuniform) inflows, expressed as a time series. The computation of storage routing may be performed by a number of methods and uses basic storage and flow relationships applied to the storage and flow

characteristics of a particular reservoir. Reservoir simulation models can be easily applied either for study purposes to develop operating criteria or for operational use to project the effect of reservoirs on current river system regulation and to compare natural and regulated flow conditions for the system in real time. The effect of reservoir spillways operated on a free-flow basis is to induce water into surcharge storage, causing the reservoir to rise and fall in accordance with the inflow, outflow, and storage relationships. The regulation of flows is automatically achieved by the storage and flow characteristics for the particular spillway and reservoir. Due to the fact that there is no chance for error in regulation based on this criterion, free-flow operation is considered to be fail-safe and highly desirable in this regard.

c. Development of Induced Surcharge Envelope Curves. The maximum elevation of induced surcharge storage depends upon the design characteristics of the dam and spillway, design flood elevations, and limitations imposed by flowage rights in the reservoir. In general, the maximum elevation of induced surcharge storage is limited to approximately 4 to 8 feet. Figure 4-1 illustrates the various levels and conditions which are involved in spillway gate operation for induced surcharge storage. A curve representing the maximum reservoir levels that would be permitted at various rates of spillway discharge when operating under the induced surcharge plan is referred to as the Induced Surcharge Envelope Curve. The envelope curve is developed as described in the following subparagraphs:

(1) A set of spillway-rating curves is computed showing the discharges that would occur with all spillway gates raised collectively by successive increments of 1 foot until fully opened (see Figure 4-2).

(2) Elevations of the top of spillway gates corresponding to various gate openings is superimposed on the rating curves (see Curve G, Figure 4-2). Induced surcharge storage could not exceed the elevations indicated by this curve without overflowing spillway gates in their partially opened position. It should be limited to a lower elevation in order to provide some freeboard, particularly after gate openings of a few feet are attained. It is desirable to provide gates with a freeboard of 1 or 2 feet above top of flood control pool when in the closed position.

(3) An elevation at which all spillway gates should be fully opened is selected after consideration of several practical factors. The benefits that may be realized from partial control of spillway releases by induced surcharge decrease very rapidly as the gate openings increase. Provisions for a higher induced surcharge level



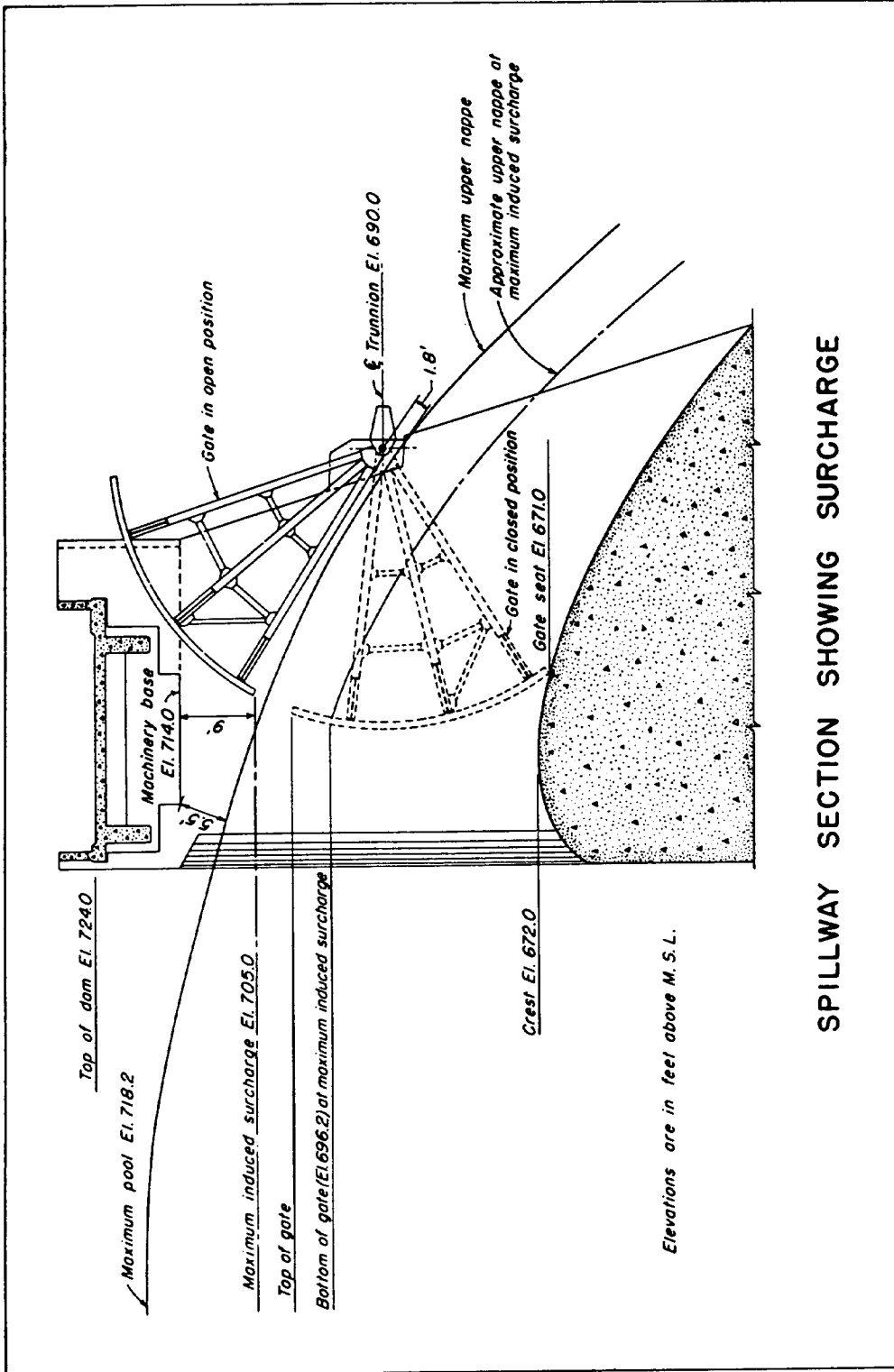

Figure 4-1

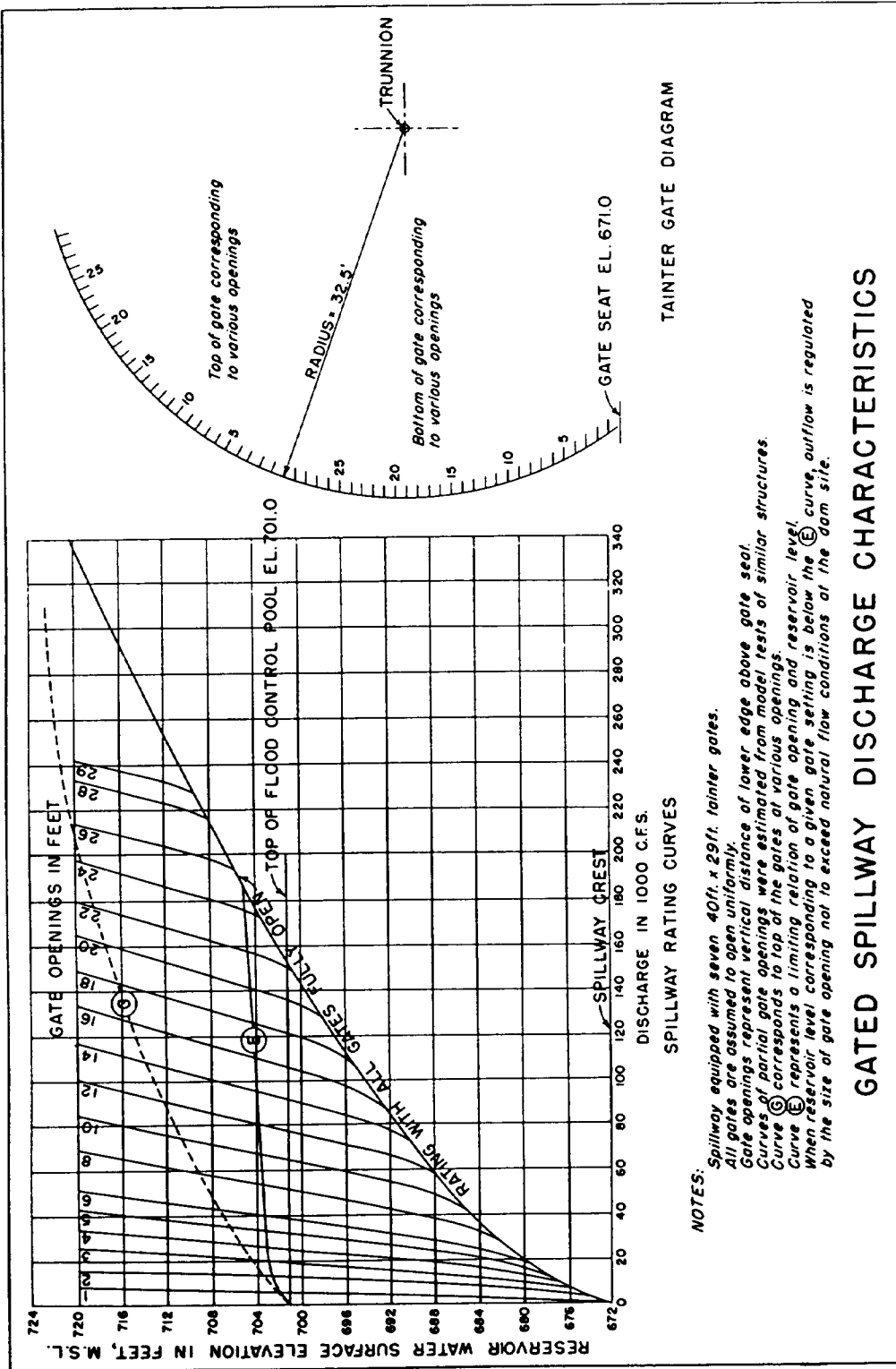

Figure 4-2

may require substantial changes in design at an increase in cost out of proportion to the advantage gained. Also, possible damage to property within the surcharge storage pool often discourages the use of induced surcharge storage more than a few feet above the top of flood control pool elevation. The selection of the elevation at which all spillway gates must be completely opened during an emergency operation should be based on consideration of the circumstances prevailing at each project.

(4) The Induced Surcharge Envelope Curve is drawn from a point corresponding to the non-damaging flood control release at the top of flood control pool elevation to the free discharge capacity of the spillway corresponding to the elevation at which all gates must be fully opened, as illustrated by Curve E, Figure 4-2. A straight-line connection would assure the minimum rate of increase in spillway discharge under critical flood conditions and may be the proper selection in some cases. However, curvature as illustrated by Curve E, Figure 4-2, permits a lower release rate in the lower surcharge ranges which would be the most frequently utilized. The minimum permissible slope of the line at the higher elevations is governed by the rate of increase in spillway discharge that may be considered acceptable during infrequent and extraordinary floods.

d. Development of Spillway Gate Regulation Schedules. Induced Surcharge Envelope Curve projects with gated spillways should have a Spillway Gate Regulation Schedule. This is a family of curves that relate inflow, outflow, and project storage. A procedure has been developed that computes the minimum volume of remaining inflow expected at a given time during a flood, based on typical recession volumes. The procedure is used to compute a family of curves (termed the spillway gate regulation schedule) that relate the inflow, and residual reservoir storage volume (including induced surcharge storage) to determine the outflow required to avoid the consequences of making regulated downstream flows greater than under a pre-project condition while at the same time providing for an orderly increase in outflows during extreme floods such that project overtopping is prevented. The first step in the procedure is to analyze recession characteristics of inflow hydrographs to obtain a recession constant that will be used in predicting a minimum inflow volume that can be expected when only reservoir elevation and the rate of rise of reservoir elevation are known. For conservative results the assumed recession curve should be somewhat steeper than the average observed recession and normally can be patterned after the spillway-design flood recession. The recession constant can be obtained by plotting the recession curve as a straight line on semilog paper, with the flow on a logarithmic scale and time on an arithmetic scale. The recession constant,  $T$ , is defined as the time required for the discharge to decrease from any value, say  $Q_A$ , to a value  $Q_B$ , where  $Q_B$

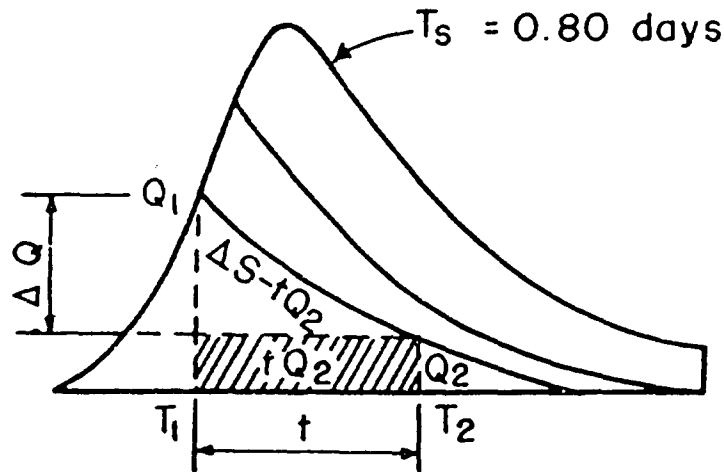

Figure 4-3. Schematic Hydrograph

equals  $Q_A/2.7$ . A relationship to compute the volume of water that must be stored for a hydrograph receded from an initial flow to a constant output flow can be derived from continuity considerations. Consider Figure 4-3, which schematically illustrates terms to be used in solving for the volumes to be stored,  $S_A$ . In the Figure 4-3,  $Q_1$  represents the inflow and  $Q_2$  represents the constant outflow. The recession constant,  $T_S$ , may be defined as:

$$T_S = S/Q = \frac{(S_A/2) + Q_2 t}{Q_1 - Q_2} = \frac{S_A + 2Q_2 t}{2(Q_1 - Q_2)} \quad (4-1)$$

then,

$$t = T_2 - T_1 = -T_S \log_e (Q_2/Q_1) = T_S \log_e (Q_1/Q_2) \quad (4-2)$$

substituting (4-2) into (4-1) and rearranging

$$S_A = 2T_S [Q_1 - Q_2 - Q_2 \log_e (Q_1/Q_2)] \quad (4-3)$$

$$S_A = 2T_S [Q_1 - Q_2 (1 + \log_e (Q_1/Q_2))] \quad (4-4)$$

For each of various inflow rates and for each of various outflow rates, compute the volume of water that must be stored,  $S_A$ , using equation 4-4. Then determine pool levels by subtracting  $S_A$  from the

storage value for the given outflow as defined by the induced surcharge envelope curve. The computations are illustrated in IHD Volume 7, Flood Control by Reservoirs, HEC 1/. The pool levels thus determined represent the maximum pool levels that should be permitted for the corresponding inflow and release rates. Obtain a family of regulation curves by plotting the pool levels corresponding to various outflows using inflow as a parameter. The family of curves is shown as Regulation Schedule A on Figure 4-4. A family of curves such as those shown in Figure 4-4 are appropriate for use in a central office, but relationships to be used as an emergency operation schedule for damtenders are more directly usable if the rate of rise of reservoir level is substituted for the inflow. This is readily accomplished by obtaining the difference between the volume of inflow and outflow for a selected time interval and expressing the volume as a rate of rise for any particular reservoir elevation. A typical family of curves is shown as Regulation Schedule B on Figure 4-5. The time interval to be used as a basis for determining rate of rise should be based on a consideration of the reservoir and drainage basin characteristics, with 1 to 3 hours being typical. Adjustment in gate openings at 1- or 2-hour intervals is adequate for most projects.

e. Testing Spillway Regulation Schedule. Spillway gate regulation and induced surcharge envelope curves should be tested by utilizing them in the regulation of historic or hypothetical floods. Several computer programs are available to do this conveniently. The tests should involve a variety of storm patterns and magnitude, that are considered reasonable for the project under consideration.

f. Methods of Operation. There are several options available during rising and falling reservoir stages which should be described in project water control manuals.

(1) Rising Reservoir Levels. When predictions indicate that anticipated runoff from a storm will appreciably exceed the storage capacity remaining in the reservoir, the opening of spillway gates may be initiated before opening is required by the spillway gate regulating schedule. Opening of spillway gates should be scheduled to limit the rate of increase in outflow to acceptable values. When outflows are required by the spillway gate regulation schedule, induced surcharge is utilized to exercise partial control over outflow rates. The elevation attained and the volume of induced surcharge storage used will vary with the volume and rate of reservoir inflow during individual floods and the exact schedule of gate operation.

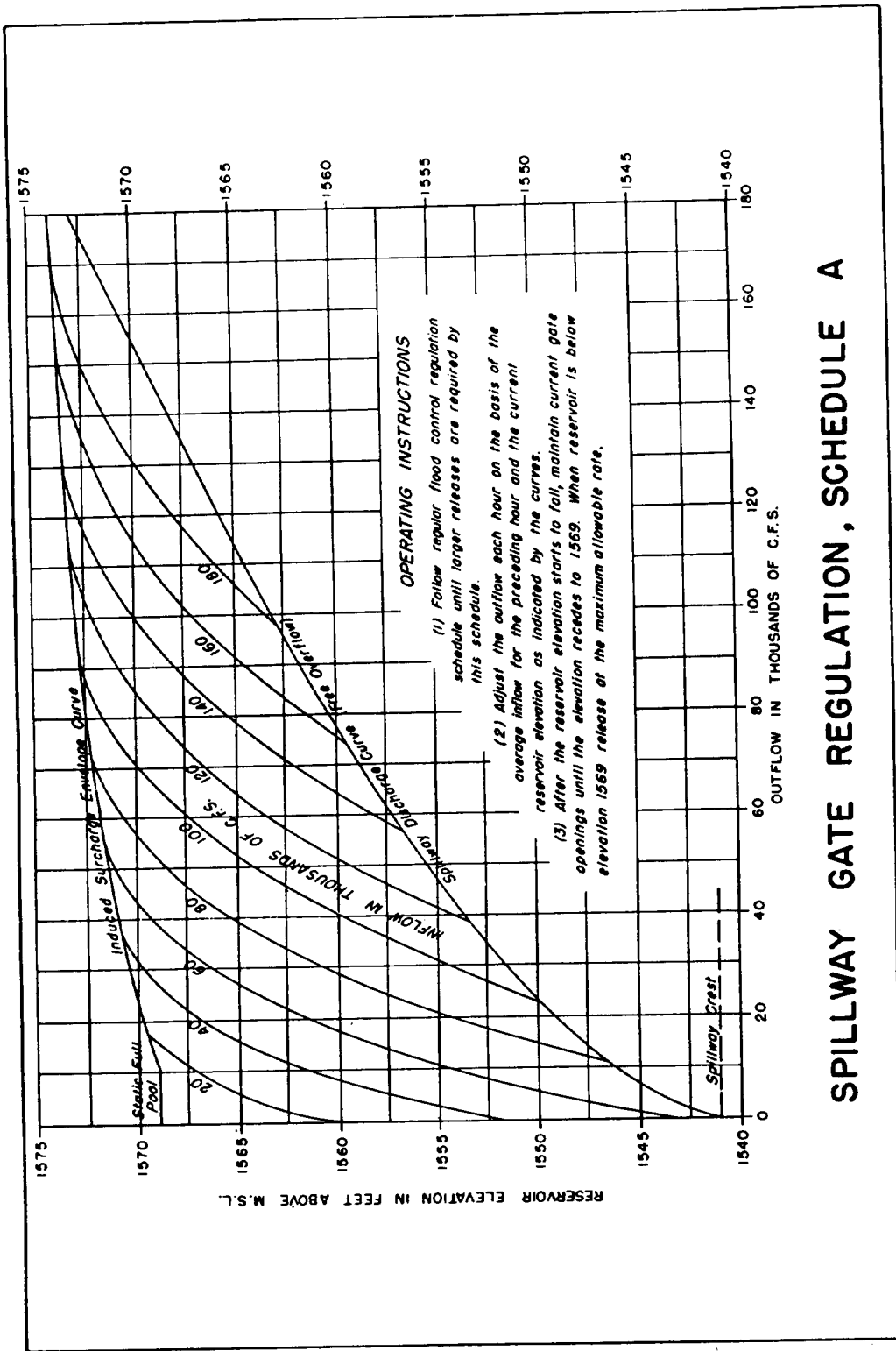

**SPILLWAY GATE REGULATION, SCHEDULE A**

Figure 4-4

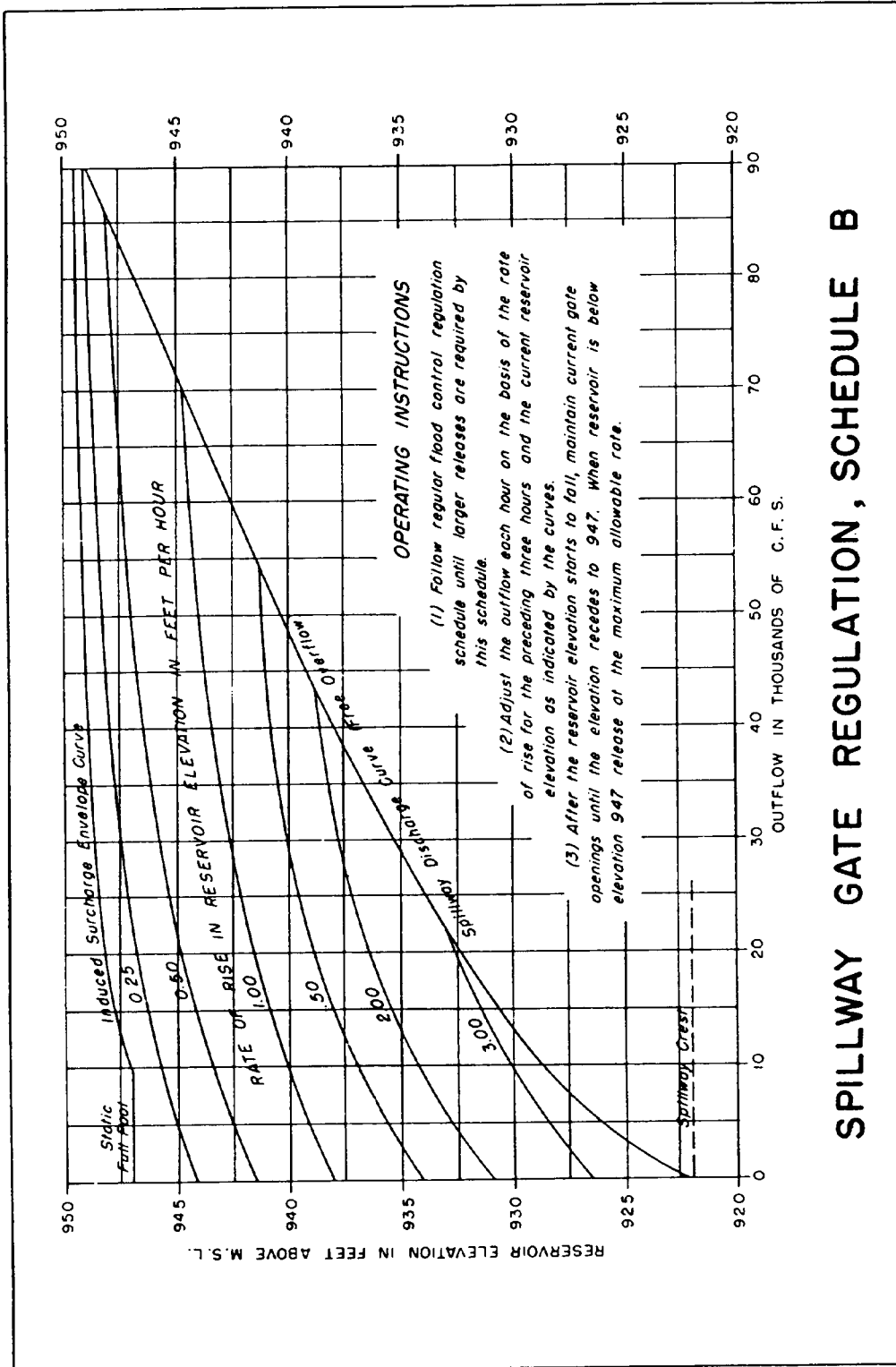

Figure 4-5

(2) Falling Reservoir Levels. For falling pool levels after surcharge storage has been induced, releases can be based on the most appropriate of several possibilities. In any event, the surcharge storage should be evacuated rapidly, consistent with downstream runoff and reservoir conditions. Upon completion of drawdown to the top of flood control pool level, the regulation schedule for releasing stored waters should be followed. The following are some of the more common procedures for drawdown of induced surcharge storage for falling reservoir levels and decreasing inflow:

- Draw down gradually to top of flood control pool level within a specified number of hours
- Maintain maximum spillway gate opening
- Release some fixed percentage (over 100 percent) of the mean inflow for the preceding 3 hours
- Make the release in excess of the inflow by some specified increment of discharge
- Make the release conform with a hydrograph similar to the natural inflow hydrograph

If all spillway gates are opened fully during the storage operation, discharge is uncontrolled until the outflow decreases to the value at which the uncontrolled condition began. Regulated operation would then begin in accordance with one of the preceding release schedules for falling reservoir levels.

g. Effect on Spillway Gate Design. The most efficient induced storage operation would normally require that the spillway gates be designed for operation at partial openings and with individual operating mechanisms. Unless the gates are designed for overtopping, it would be desirable for the height of gates to be 1 or 2 feet greater than required for the induced surcharge operation since it will not be feasible to raise all the gates simultaneously to obtain the desired discharge.

#### 4-6. Outlet Works for Water Supply

a. General Considerations. The design requirements for outlet works in connection with their use for water supply functions are different from those for flood control. Generally, the water releases for irrigation, navigation, municipal, industrial, or other water uses are fairly uniform over a period of days or weeks as compared with the rapidly changing requirements for flood control,



and they may be of relatively low magnitude. The use of outlet works for water supply functions may involve special operating problems which should be taken into account by the water control manager.

b. Special Requirements and Problems. Outlet works that are designed primarily for flood control may have some restrictions when used for low-flow regulation because of cavitation. Also, operation of flood control gates may not allow the required degree of control for gate settings that precisely achieve the low-flow requirements. Some types of gate operating mechanisms have a tendency to "creep" over a period of time, and the gate setting must be re-adjusted periodically to maintain the desired uniform outflow from the project. The water control manager must also be aware of hydraulic problems of long-term operation of outlet works, such as the adverse effects of spray that may result from the use of a ski-jump energy dissipator, turbulence or undesirable flow patterns in the downstream tailwater area, problems related to ice formation and cold weather operation, and the general continuity of operation of outlet work facilities where they are generally unattended except as required to make adjustments in outflows.

#### 4-7. Diversion and Bypass Structures

a. Project Purposes and Types. Diversion structures and systems vary widely in size, complexity of operation, and degree of control. In many cases excess flood water is carried away from a main stream by a control structure and auxiliary channel to reduce flood flow and stages at potential damage centers on the main stem. Water supply diversions for M&I and irrigation purposes are the most common and include closed conduit bypass facilities, as well as open channel flow diversions. Other reasons for diverting flow may be for recreational purposes, fish and wildlife enhancement, suppressing saltwater intrusion in estuaries, or lowering the ground water table. The least common in number are manmade navigation channels, e.g., the Tennessee-Tombigbee Waterway. Also, diversions to existing channels for other purposes may help provide navigation depths incidentally. Water is diverted back into some reservoirs at night following a hydropower generation cycle (pumpback) and reused for the same purpose in the next generation cycle. Power is also generated by passing flow through turbines in route to an auxiliary channel where the diversion is for other purposes. There are diversion systems whose objectives are seasonal in nature related to high flow only, low flow only, and to both high and low flow conditions. Still others operate continuously, and some control the flow both into and out of given area.

b. Regulation Procedures and Schedules. Diversion projects that have uncontrolled structures do not require water control decisions; however, it is often necessary to anticipate when these structures will begin and cease operating in order to notify the general public, evacuate auxiliary channels, and take other action as appropriate. The most complete hydrometeorological data available, including forecasts of stage and discharge, should be used when applying regulation procedures. Detailed analyses are often made for controlled structures because of the importance attributed to water management, whether it be for flood control, water supply or other project purpose. Withdrawal from a stream or impoundment for any reason can be a highly sensitive issue that leads to court claims, and signed agreements with appropriate interests are advisable that address both normal and rare climatic events. Long-range regulation schedules are made in an effort to define the duration of an event and to define stage and discharge hydrographs upstream of, at and downstream of the control structures. Various factors are taken into account: time of inundation, stream and channel capacities (stage or flow reduction targets), navigation depths, relationship to dredging, levee grades, river stage and lake levels, water quality in lakes, streams and estuaries, and seasonal considerations. In general, physical operating characteristics of the control structure, such as energy dissipation and velocities, are critical.

4-8. Hurricane or Tidal Barriers. Hurricane barriers are operated to protect coastal communities from tidal flooding associated with severe storms. The design and operation of projects take into account the effects of interior runoff, pumping station requirements and availability of ponding. It is also necessary to know how long it takes to open and close navigation gates and whether navigation gate opening operations can be initiated when there is significant head differential on a gate. The manager should also be aware of the discharge capabilities of emergency sluices, in case the navigation gate becomes stuck in the closed position or has to be closed for maintenance purposes for an appreciable length of time. It is important to have firsthand knowledge of the protected area and what damages would result at various water levels.

#### 4-9. Interior Flood Control Facilities

a. General. Interior floodwater is normally passed through the line-of-protection by gravity outlets when the interior water levels are higher than water levels of the exterior (gravity conditions). The floodwater is stored and/or diverted and pumped over or through the line-of-protection when exterior stages are higher than that of the interior (blocked gravity conditions). Gravity outlets, pumping

stations, interior detention storage basins, diversions and pressure conduits are primary measures used to reduce flood losses in interior areas. Other measures, such as reservoirs, channels, flood proofing, relocation, regulatory policies, and flood warning/emergency preparedness actions, may also be integral elements of the interior flood loss reduction system. Reference is made to EM 1110-2-1413, which provides general guidance for the analysis of interior flood control facilities.

b. Operational Criteria. Generally the Corps plans, designs and documents detailed operating criteria for newly completed interior flood control facilities for use by the local interest responsible for operation and maintenance. These criteria should include instructions for obtaining and reporting appropriate hydrologic data, including current and forecasted values of exterior river stages, interior area rainfall and ponding levels. The criteria should describe proper use of the data to effectively operate the facilities. Provisions for obtaining supplementary data should be included, when necessary. General flood emergency preparedness plans and all arrangements required to assure timely closure of gravity drains, to implement emergency closures, and to operate pumping plants should be carefully described. Periodic schedules for inspecting, testing and maintaining the facilities should be defined.

c. Legal Requirements. The capability of an interior flood loss reduction system to function over the project life must be assured. This requires legally binding commitments from the local sponsors of the project to properly operate and maintain the system. Real estate requirements and specifications for operating and maintaining detention storage areas, pumping facilities, and conveyance networks, are integral to all agreements for implementation of an interior system of flood measures.

#### 4-10. Hydroelectric Power Facilities

a. General. The functional utilization of hydropower facilities encompasses a broad spectrum of technical knowledge. At Corps hydropower projects, the power units, control facilities, power transformers, switchyards, and operational techniques all embrace complex equipment which are under the operational control of the Corps. However, there is the much broader consideration of electrical power system operation and integration, which requires a basic understanding of not only the physical hydropower facilities, but also regional electrical power system operation. This knowledge is needed to make judgments that affect the operation of the total

regional electric power resource and the interrelationship of power operation with the management of multipurpose river developments.

b. Engineering Manual On Hydropower (EM 1110-2-1701). This manual provides guidance on the technical aspects of hydroelectric power studies from pre-authorization through the General Design Memorandum (GDM) stage. Specific areas covered include need for power, determination of streamflows and other project characteristics, estimation of energy potential, sizing of power plants, cost estimating, and power benefit analysis. Other engineering manuals have been prepared that cover details of design for selected hydropower facilities such as powerhouse design and selection of turbines and generators. While EM 1110-2-1701 primarily deals with hydropower, it also provides much background information that pertains to operation of power systems and the general features of hydroelectric development.

c. Major Hydroelectric Facilities. Hydropower projects are classified by type of operation as run-of-river, pondage, storage, pumped storage, and reregulating projects. All hydropower plants include the following major hydraulic components: dam and reservoir, intake, conduit or penstock, surge tank (when necessary), power unit, draft tube, and tailrace. The types and designs of each of the components are determined by the specific design requirements for individual projects, and they vary widely depending upon the type of operation and physical characteristics of the project. The heart of a hydropower plant is the powerhouse, which shelters the turbines, generators, control and auxiliary equipment, electrical buswork and disconnects, and sometimes erection bays and service areas. Transformers are usually placed on or adjacent to the powerhouse, and switchyards are nearby.

d. Plant and Unit Control Systems. Control equipment is necessary to facilitate the automatic or manual operation of the power units and other necessary power plant equipment. Control systems vary widely in scope and complexity, as a function of the size and staffing of the plant, the level of operator skill and responsibility, the need to automatically regulate power generation to outside demands, and the desirability and location of the central electrical control and dispatch center. Unattended small scale hydro plants often demand apparently disproportionate control equipment expenditures because of the need for automatic fail-safe operation and outside plant trouble reporting. Larger multi-unit attended plants often have a central control room and automatic control requiring large computer based Supervisory Control and Data Acquisition (SCD) control systems.

e. Plant and Unit Operation. In general, individual power units, multiunit power plants, and large interconnected power systems are operated by a variety of manual and automated control systems. In recent years, there has been a significant increase in the use of automated systems for operating hydropower plants remotely from a centralized control center. At Corps of Engineers projects, the hydropower facilities and control systems are generally operated under the supervision of the Operations Division, which has direct responsibility for the operation and maintenance of the individual projects. The operation of these facilities for day-to-day regulation and functional management of these resources to meet all water management goals, including hydropower, is performed in accordance with instructions and schedules provided by the Reservoir/Water Control Center or other water regulation unit that has responsibility for scheduling plant operation. Individual units may be started and placed on line in accordance with operating schedules and the needs for power. The starting and stopping of individual units may be done manually by plant operators or remotely from the power plant control room or other designated project controller location. The units may be operated according to a specified load, or they may be placed under Automatic Generation Control (GC). When units are operated to meet a specifically scheduled load, it is termed "block loading." Such loadings are generally specified as hourly values, which reflect the anticipated needs for power generation and the needs for all other water demands. The changes as required in scheduled plant loadings are performed by the plant operator from the project control room or remotely from a designated project controller or central dispatch facility. Under certain conditions, units may be operated under "speed no load," in which the unit is rotating at the speed which is synchronized with the power system operation, but without load or significant generation of electric power. This type of operation may be necessary to help provide inductive or capacitive reactance to the power system operation and enhance system stability. It also provides for spinning reserve capacity which may be required for power system operation to meet unforeseen changes in plant or system loads. The methods of scheduling and coordinating the regulation or power plant operation are discussed later in this section.

f. Integration into Regional Power System. The electrical power produced at Corps of Engineers projects in the United States is integrated with electric power produced by other utilities. Under the terms of the Flood Control Act of 1944 (Public Law 78-534, dated December 22, 1944) and related legislation, the power produced by Corps of Engineers projects is marketed to the utilities and other direct service customers by five regional power marketing administrations (PM's) of the Department of Energy. In addition to marketing, some of the PM's also provide transmission and dispatching

services. The regional electrical power networks in the United States are complex and highly integrated systems whose operation is made possible through formal agreements between utilities or through informal working relationships to enhance the overall capability of individual utilities.

g. Control Equipment. Units or plants at major hydroelectric power stations may be loaded on the basis of predetermined fixed schedules (block loading), or they may be loaded through use of load-frequency control equipment known as Automatic Generation Control (GC). In those cases where system control of hydroelectric power facilities represents a major portion of the system generation, this equipment is normally part of the control facilities provided in the power dispatching control center operated by the Power Marketing Agency (PM). The function of GC is to control power generation automatically at one or several plants in a system in response to the moment-to-moment load variations that are imposed on the system. It is also used to pro-rate generation automatically to several plants as required to meet a major portion of system loads, on the basis of predetermined functions which represent the proportional loadings of individual plants. These functions, known as "break point" settings, are individually determined for each plant from power system simulations that project the expected loads and resources into the future, usually for periods of one to five days. The "break point" settings may be changed daily as a function of system requirements. In actual operation, the plant loadings computed by the GC are converted to electrical signals, and they are received at each plant at approximately 1-second intervals. The power plant internal computer automatically apportions the plant load change among the generating units on-line at that particular time. The use of the equipment is a very important tool in the power scheduling and dispatching process. The "break point" settings determine the actual loadings of each plant as a function of the continuously varying power requirements, and they determine the resulting streamflows at each project under GC. It is vital that the water manager who has projects operated under GC be familiar with interrelationships between system controllers and the planned use of this equipment for scheduling plant operation for normal and emergency conditions. Although the planned and scheduled use of power plants is coordinated through the water managers, the ultimate plant operation is determined by the automatic generation control equipment for those plants under its control. It is, therefore, important that the plant operation be continuously monitored to assure that all of the water management goals are being met and to take corrective action when necessary.

h. Special Operating Problems. The problems of power operation vary widely among projects and systems, depending upon the importance

of hydropower in relation to other project purposes, the methods of hydrosystem control, and the system integration of power regulation with other multipurpose water management requirements. The water manager is concerned with two basic types of problems:

- Project and system regulation on a seasonal basis, when power is a consideration in the water control plan
- Scheduling power regulation on a daily, weekly, or monthly basis to meet the power needs in conjunction with the other water uses

Both types of problems require a large degree of coordination with all users.

(1) Seasonal Reservoir Regulation for Hydropower. Chapter 3 describes the principles of hydropower system operation and the methods for developing reservoir regulation schedules for reservoir projects with hydropower facilities. The Annual Operating Plan (OP) is developed on the basis of each year's hydrologic conditions, system power requirements, and multipurpose requirements and goals for reservoir regulation. The studies required for developing the OP must be coordinated with other power interests and local or regional groups that have an interest in the multipurpose aspects of water regulation.

(2) Coordination. There is an imperative need for coordination between the Corps of Engineers and the Power Marketing Agency (PM) when formulating power production and power marketing strategies and when integrating the operation of power facilities within the regional power grid. This coordination involves many aspects of project operation and reservoir regulation at Corps projects, including the development of the operating plan to achieve the power operating goals, scheduling reservoir releases, and dispatching power under normal and emergency conditions. All coordination requires administrative procedures, technical evaluations, and detailed working arrangements to assure that the responsibilities of the two agencies are met. This is generally accomplished by executing formal Memorandums of Understanding, which define specific duties and responsibilities, establish coordinating groups composed of agency representatives which oversee the operations, and form work groups assigned to specific tasks. Similar arrangements are made with other operating utilities in the region. During operation, however, there are often circumstances which require unplanned minor departures from the operating plans in order to satisfy unforeseen requirements or desires for river regulation. For some cases, departure from operating plan schedules and guidelines may have a significant effect on meeting one or more of the water management goals, and the problem

may have to be referred to an appropriate administrative level for resolution. Chapter 8 deals with interagency coordination in greater detail.

(3) Scheduling and Dispatching Power. Scheduling and dispatching power from Corps projects are performed in accordance with the basic operating strategies and criteria contained in the Annual Operating Plan (OP) and Water Control Manual. As mentioned previously, the OP consists of guide curves and other operating guidelines that are generalized from power operation studies performed on the basis of mean monthly historical streamflow data and estimated load and resource evaluations. It is also necessary to base the actual operating schedules on current hydrologic and power data, together with forecast data. For small or relatively simple systems, the schedules can be determined manually from analysis of current data and estimated projections of future operations. For large integrated power systems, however, the schedules are usually determined by computerized simulations, which provide current analyses of all hydrologic and power generation data, load forecasts, interchange requirements, and plant and unit status conditions on a real-time basis and conform to the constraints of operating rule curves. Simulations cover in detail several days to a week in advance, and more general projections are made for periods up to 30 days or more in advance. The actual operating schedules are then derived from the simulations of project operation. The daily operating schedules are forwarded to the project office (usually by teletype) for plants not on centralized control, or they are inserted into the system controller at the power control center. They may indicate hourly generation values for block loaded plants and anticipated plant loadings, unit status, and "break point" settings for plants operating under control of the GC equipment.

(4) Power Dispatchers. The continuous operation of the power system is under control of the power dispatchers, who monitor all aspects of plant and system operation. The dispatchers are highly trained specialists who control the flow of power in the system under normal operating conditions. They also recognize any abnormalities or departures from planned system operation and take immediate action to correct the problem and restore the system to normal operation. Potential problems include unusual load demands, power outages, equipment failures, or loss of transmission. The dispatchers are in frequent communication with plant operators who control the operation of hydroelectric facilities at their respective plants. The plant operators are responsible for the operation of their plants in accordance with the operating schedules and other operating criteria that may affect water regulation and the operation of the physical facilities.



(5) Constraints on Peaking Operation at Hydropower Plants.

Many hydroelectric plants are designed for meeting peaking and intermediate load requirements that result in a low load factor operation. Some plants generate only when peak loads occur, generally less than 8 hours per day, and their generation is scheduled to help meet the morning or afternoon peak loads. Other plants are scheduled for a more continuous operation but still respond to daily variations in system loads. While there are many advantages to operation at peak loads, fluctuating outflows resulting from this operation may cause water regulation problems. Environmental considerations, such as the effect of fluctuating water levels on fish and wildlife, aesthetics, navigation, and public safety, are all considered in the planning, design and operation of peaking power plants. In some cases, the water fluctuation problems related to peaking operation are completely met by constructing reregulating reservoirs immediately downstream from peaking power projects. Where it is impractical to construct reregulating reservoirs, specific operating limits for fluctuations in power production and/or water level in the river system below the projects are developed on the basis of studies made during the design phase. Pondage projects, which are developed in tandem on a major river, are operated as a system with regard to peaking power operation. The total system output is shaped to meet the fluctuating power loads, so that all plants share in loads and fluctuations in reservoir and tailwater water levels. The analysis of this type of system operation is accomplished through use of the various computer models available for this purpose. In actual operation, there may be requests for restrictions in peaking operation beyond those set forth in the design or operational studies. These requests are generally a result of changed environmental conditions or other unforeseen conditions. Requests of this nature must be carefully analyzed.

(6) Electrical Operating Reserves. An electrical power system is designed to guarantee reliable service to customers. This requires that reserve capacities be available to cover forced outages, maintenance outages, abnormal loads, and other contingencies. Typically, power system resource planning is based on providing about 20-percent reserve capacity above the expected annual peak load. This capacity is called the system planning reserve. In day-to-day system operation, an operating reserve of 5 to 10 percent of the load being carried must be maintained at all times. Half of this must be spinning reserve (capacity which is rotating but not under load; see Paragraph 4-10e, Plant and Unit Operation), and the remainder is standby reserve, which must be available in a matter of minutes. The spinning reserve is used to handle moment-by-moment load changes, while standby reserve is used to cover unexpected power plant outages.

(7) Load Forecasting. Load forecasting is one of the most important factors in scheduling and dispatching power. Normally, this is done by the PM, as part of their service in the scheduling process. When the federal plants are interconnected with private utilities and are operated under power exchange agreements for coordinated system operation, the federal plants may also provide interchange energy to help meet the utility system loads. System load forecasts prepared in conjunction with daily operation are short-term hourly and daily loads, as compared to generalized monthly load forecasts used in resource planning and annual operation planning. The actual daily load forecasts are prepared from analyses of recent weather and load data, forecasted weather data, and other variables such as time of day, day of the week, and time of year. The load may be separated into several components, such as industrial, commercial, and residential, and detailed computerized load forecasting programs have been developed. The load forecasts are then used to develop individual plant schedules.

(8) Emergency Control Procedures. The requirements for scheduling the use of power resources are based on normal operation of generation equipment, transmission and substation systems, and anticipated power loads which conform closely to the scheduled amounts. Unanticipated outages in system operation may arise and require immediate compensation in the electrical system to prevent a breakdown in the total system operation. Emergency actions by the dispatchers and power schedulers are required that may affect both the use of generation equipment at hydroelectric plants and conditions of streamflow and water levels at individual plants. In emergencies, changes in power system operation must usually be instituted in seconds or minutes, and the recovery of the system may require as much as an hour or more. In order to assure that normal operation can be achieved within the overall capabilities of the power system, the scheduling must allow for sufficient reserves of generation capacities to meet such requirements (see Paragraph (6), above). Short-term or disturbance-related power shortages are met by generation reserves. This unused generator capacity is available for use in the event of a failure in the power generation, substation, or transmission facilities. "Operating reserve" is generating capacity that can be made available and loaded within 10 minutes on a sustained basis. "Spinning reserve" is a component of operating reserve and is on-line, unloaded, and ready to pick up immediately on demand. In extreme emergencies, where the power system is unable to provide sufficient generation to match load, automatic devices institute a program of "load shedding." Coordinated automatic load shedding should be established to prevent the total loss of power in an area that has separated from the main network and is deficient in generation. Load shedding should be regarded as an "insurance program" and should not be used as a substitute for adequate system

design. The emergency conditions of power plant operation discussed in this paragraph are beyond the normal scope of coordination between the Corps of Engineers and the PM. It is mandatory that the water manager be informed immediately of any large scale interruption of the power system and take actions as necessary to preserve the water regulation goals and inform others regarding the emergency conditions.

#### 4-11. Fish Passage Facilities and Use of Water Control Facilities for Fishery Enhancement

a. General Considerations. There are two classifications of fish life that are dealt with in the development of fish facilities for water control projects. These are:

- Anadromous (migrating) fish species such as salmon or shad, which basically maintain their habitat in the ocean and ascend from the sea into rivers to breed
- Resident fish such as bass and trout, which are bred, reared, and maintain their habitat in rivers

Specially designed facilities for fish passage and enhancement of fish life have been incorporated into many water control projects. These facilities may include fish ladders; fingerling fish bypasses; fish turbines, fish pumps, water conduits, or spillways or outlet works that provide water to attract fish into fish passage facilities; fish "elevators"; and facilities that release the desired quantity and quality of water to enhance fish life in downstream areas. In addition to these physical facilities, other fishery activities, facilities and operations which may be related to water management may include:

- Fish hatching and rearing to supplement natural fish runs and establish new runs
- Improving fish spawning grounds
- Transporting fish by truck and barge
- Modifying spillways to reduce nitrogen supersaturation during times of spill and adjusting or reducing spill to help mitigate nitrogen supersaturation
- Performing basic and applied research in fish biology, particularly in regard to the effects of dams and reservoirs

- Regulating water releases to meet the streamflow and water level fishery requirements in the water control plan

b. Fish Passage Facilities. Dams are designed to preserve anadromous fish runs, primarily the salmonoids. Fish ladders provide safe upstream passage of adult migrants past water control structures. Years of experience in the operation of properly designed fish ladders have shown them to be a proven method for passing upstream migrants through a series of dams whose hydraulic heights range from 50 to 150 feet. Passing the downstream migration of juvenile anadromous fish, however, is not accomplished with the same degree of reliability. Various methods, such as constructing fingerling bypass facilities at dams, transporting migrants by truck or barge, passing fish through spillways rather than power units by induced spill, and increasing streamflow through reservoirs during migration, have been tested. Multilevel intakes, usually considered a means to provide general water quality control, may have been justified primarily to meet the fishery requirements for control of water temperatures or other water quality parameters that affect fish life. Scheduling the operational use of multilevel intakes is usually based on the fishery needs, and the water manager must have full knowledge of the fishery management programs and the particular requirements for the river reaches affected by their use.

c. Fish Attraction Water. One of the objectives in the design of fish ladders is to provide the proper water currents in the channel area adjacent to and immediately downstream from the entrance of the ladder at the tailwater of the dam. These currents are essential in leading the upstream migrant fish into the fish ladder approach channels (including power plant tailwater fish channels) from the tailwater area or open river. "Fish attraction water" is the term applied to the water which is supplied for the specific purpose of creating these currents. The hydraulic design of fish ladder entrance conditions is usually based on hydraulic model studies. Relatively large amounts of water are required to create the currents (1,000 to 2,000 cubic feet per second), and these may be supplied by large capacity pumps, a hydroelectric unit whose draft tube discharges into the fish ladder approach channels, or by direct diversion of water from the headwater to the approach channels through gravity supply systems. These facilities must be operated during the season of upstream fish migration. The power output from fish turbines is fed into the power system and represents an element of the hydropower resource, but the output is proportionally less than the main units because of small discharges. Fish pumps simply recirculate the water in the tailwater area, but they require relatively large amounts of power to operate them. Direct diversion of water to supply fish attraction water is the least efficient method, considering the loss in energy that would otherwise be

available by the use of the water for power production. In summary, fish attraction water is a necessary adjunct to the operation of fish ladders, and the use of water or power to supply it has a bearing on the efficient use of water for all purposes.

d. Fingerling Fish Bypass Facilities. The operation of fingerling fish bypass facilities of the type used in the dams in the lower Columbia River system require flows ranging from 300 to 600 cubic feet per second in the intake area, but about 80 percent of this amount is pumped back from the point where the water enters the bypass diversion channel. The remaining 20 percent (about 60 to 120 cubic feet per second) flows through the diversion channel or conduit to the tailwater, and this amount is lost to the functional utilization of water at the project. The intakes for these facilities are constructed in conjunction with the power unit intakes. Fish screens that are located in the power unit intakes divert the fingerlings up through the gate well slots, thence through orifices or weirs into the fishery bypass collection channels and bypass conduits. The hydraulic systems which comprise these bypass facilities are complex, and their operation must be carefully monitored to assure that the fish are being transported efficiently past the power structure. Changing conditions of pool levels and power discharges may affect their operation, and deficiencies in their effective passage of downstream migrants may require adjusting power plant operation or inducing spill as an alternative means for passing the fish.

e. Increased Streamflows to Aid Passage of Downstream Migrants. In view of the difficulties of passing downstream juvenile migrating fish past a series of large dams, particularly those with hydroelectric facilities, a number of alternative methods are being tested in order to achieve the most satisfactory and economic solution. The use of fingerling bypass facilities is still in the developmental stage, and until these facilities are proven fully effective and are installed at all plants, it may be necessary to enhance the passage of downstream migrants by induced spill of water at critical times. Further, due to longer travel times of fingerling migration that result from the impact of reservoirs in the river system, it is desirable to increase streamflows by releasing water stored in upstream reservoirs during the downstream fish migration. These two factors are considered in the daily management of the water control facilities in conjunction with all other project purposes. Although the annual operating plans may recognize and account for fishery requirements, under actual operation the many variables that affect the daily fishery needs cannot be foreseen more than a few days in advance. This is particularly true of the need for induced spill and increased discharge through the reservoirs during critical times in April and May. A mathematical modelling system to simulate

and evaluate hydraulic and fishery conditions is now being used experimentally as an aid in scheduling the water regulation during the critical times of downstream fish migration.

f. Fish Hatcheries. Water intakes for the hatcheries may be from the reservoir or from the river channels downstream. Water quality characteristics including temperature, pH, dissolved oxygen, and nitrogen must be maintained within specified tolerances.

g. Control of Dissolved Gas Supersaturation

(1) Dissolved gas supersaturation occurs in rivers below dams as water plunges over a spillway into a deep stilling basin. Gas supersaturation may injure juvenile and adult fish through the occurrence of gas bubble disease. This condition results from long exposure to water supersaturated with dissolved air exceeding the tolerance level of the fish. The problem has been studied extensively and measures have been taken to partially alleviate the problem. Although it is possible to reduce gas supersaturation caused by spill at dams, there is no way to reduce it to complete non-damaging levels under all conditions of streamflow. Also, threshold levels at which gas supersaturation becomes damaging to fish life are uncertain. Nevertheless, specific efforts are being made to reduce supersaturation by modifying the structural shape of spillways, by adjusting the water regulation in the system to reduce spill, and by adjusting the distribution of spill.

(2) The design and construction of "flip lips" on the downstream ogee section of spillways has been accomplished for several Columbia and Snake Rivers dams. Prototype measurements have indicated a significant reduction of gas supersaturation at those projects, in the low to medium range of their spillway design capacity. These flows correspond to those experienced during normal flood runoff conditions. It is believed, however, that when spill occurs of the magnitude which would be experienced in major floods, the effects of the "flip lips" are drowned out, and they would have little or no effect on reducing gas supersaturation. Overall, the "flip lips" reduce the duration and frequency of gas supersaturation and are therefore beneficial in alleviating the problem. The use of upstream reservoir storage to reduce spill may also alleviate the problem. This solution must be considered with respect to all other aspects of reservoir regulation. Normally, the plan for system wide operation is also to lessen the spill at downstream locations and therefore is consistent with minimizing gas supersaturation. However, it is sometimes possible that the timing of the spill reductions could be scheduled to better coincide with the fish runs. These objectives can be incorporated on a long-range basis into the

annual operating plan, and on a short-range basis into the day-to-day scheduling.

(3) Probably the most direct way to reduce gas supersaturation through water management is by adjusting spill between projects under real-time operation. This can be accomplished by shifting power loads to maximize spill at those projects where the spill produces the least gas supersaturation. Also, it may be feasible to arrange for increased power loads on the hydropower system by transferring loads from thermal plants or other outside resources. Special computer programs are available which simulate the levels of gas supersaturation and can be used for analyzing and projecting the levels resulting from the scheduled spills in the system. These programs use current system data, which is essential for initializing and evaluating the effects of current conditions of spill.

h. Coordination of Regulation for Fishery. Detailed knowledge of the fishery resource and the responsibility for its management are shared by the state and federal fish and wildlife agencies, Indian tribes, and international organizations. These agencies represent the interests of sport and commercial fishing, Indian tribes whose treaties may involve rights for fishing, and the fishery interests of other countries who share in the responsibility for fishery management through treaties and compacts. Input from all of these organizations are important for determining the specific needs of the management of the fishery resource as it pertains to the management of water control systems. This requires a coordinated effort among fishery and water managers to include fishery needs in the water control plans and to carry out these requirements in the day-to-day management of the water and fishery resources.



Figure 4-6. Old River Control Structures, Old River, Louisiana;  
New Orleans District



## CHAPTER 5

### WATER CONTROL DATA SYSTEMS

#### 5-1. General

a. Purpose. This chapter will summarize the technical aspects required for the planning, design, operation, and coordination required for water control data systems. The information presented is arranged by three major components: (1) data observation and collection at field stations, (2) transmission of data and (3) data management and processing in a database. The presentation will address the mechanisms and equipment associated with each of these components.

#### b. Basic Requirements

(1) The effective management of water control systems is dependent in part upon knowledge of current project and hydrologic conditions, project capabilities and restraints and water control elements in the river system that affect streamflow, water level, and water quality.

(2) The water control data system must be designed to meet the specific needs of the water control manager. The data system must include facilities to perform the following functions:

- observation and storage of data at field stations
- transmission of data from field stations
- decoding and validation of transmitted data
- storage and retrieval of data in a database
- management of a water control database
- providing graphical and tabular data displays
- exchanging data with other users

(3) ER 1110-2-249 establishes requirements for management of water control data systems.

c. Master Plans

(1) Master plans for water control data systems are prepared in conformance with ER 1110-2-240. In general, master plans include all the essential information that set the requirements, justification, scope, and recommended procedures for implementing water control data systems. Accordingly, they:

- outline the system performance requirements, including those resulting from any expected expansions of Corps missions
- describe the extent to which existing facilities fulfill performance requirements
- describe alternative approaches that will upgrade the system to meet requirements not fulfilled by existing facilities, or are more cost effective than the existing system
- justify and recommend a system considering timeliness, reliability, economics and other factors deemed important
- delineate system scope, implementation schedules, proposed annual capital expenditures by district, total costs, and sources of funding

(2) ER 1110-2-240 describes the administrative procedures for preparing and updating master plans for water control data systems. It sets forth the responsibilities associated with developing the water control plan, coordinating its approval, making funding requests for the costs of the proposed facilities, and updating plans as needed on an annual basis. Guidance for the management of dedicated water control data systems including that equipment and software used for acquisition, transmission, and processing of real-time data for regulating Corps projects is prescribed in ER 1110-2-249.

(3) The master plan is prepared by Division water control managers based on detailed studies of communication alternatives as well as all other aspects of the overall water control data system requirements. Because of the rapidly advancing technology, there is no one established method or standardization of design for a water control data communication system. Each existing system has been developed on the basis of design conditions for that particular system. However, considerable experience has been gained to date by Division and District offices in developing these automated networks. Information of these various systems are disseminated through technical conferences and/or workshops on water control management conducted or coordinated by HQUSACE.

5-2. Data Observation and Storage at Field Sites

a. General. A majority of the data input into the water control data collection system are time-variable data. They represent observations of the conditions of water regulation at various projects, water levels and water quality in the river system, and those hydrometeorological elements that affect any of these conditions or elements. Although non-variable data may be included in the data processing system (such as project characteristics related to reservoir capacities, outflow limitations, etc., or hydrologic parameters that define the runoff characteristics of the river system), the data gathering system is designed primarily to observe, process and transmit time-variable data. The time-variable data observed and collected may be classified in three broad categories:

- Hydrometeorological data
- Project data
- Water quality data

b. Hydrometeorological Data

(1) The function of hydrometeorological data is to provide current information by direct observation on all significant elements that affect runoff within a drainage basin or river system.

(2) Some of the hydrometeorological elements that may be observed are:

- water levels in rivers, lakes, and reservoirs
- precipitation as measured at ground stations or as estimated by radar, satellites, or other sensors
- air temperature as measured at ground stations or by upper air atmospheric soundings
- pan evaporation as measured at project sites
- snow sensors or snow courses which measure the depth and water equivalent of the incremental snow accumulation, and/or the total accumulation of snow in the snowpack, as determined from ground measurements or remote sensors

- snow covered area, as determined from aerial or ground reconnaissance, or by remote sensors from satellites or aircraft
- conditions of river ice, as measured at key locations to determine ice thickness and locations of ice jams

(3) In addition to these hydrometeorological elements, observations may also include measurements of soil moisture, soil temperature, and ground water. They may also include atmospheric measurements of humidity, wind speed, wind direction, and solar radiation.

(4) The design of a data network must be based on many factors, including consideration of the hydroclimatic regime, project regulation and forecasting requirements. The principal difficulty in defining the specific coverage and number of data stations is that of striking a practical balance between a theoretically complete coverage and the practical limitations imposed in obtaining and processing the data collected. The judgements to be made as to the amount of coverage that are justified for a particular river system must be based on hydrologic analysis, estimates of cost and benefits for incremental increases of coverage, and a general knowledge of the reservoir regulation and forecasting problems for the subject river system.

(5) The streamflow and rainfall reporting networks are developed in cooperation with the U.S. Geological Survey and the National Weather Service. These cooperative programs largely define the scope of coverage of the hydrometeorological networks. In some areas, the cooperative network and stations owned and operated by the Corps supplement each other. Section 5-6 describes the coordination of data collection programs in greater detail.

(6) The design of sensors, equipment, and facilities required in the construction of reporting stations is preferably performed in the project design phase and documented in an appropriate design memorandum. It is not within the scope of this manual to present specific design information or alternatives.

c. Project Data. Time-variable project data are essential for project regulation. Hydrologic data, for observing and interpreting water control functions at the project, is part of the hydrometeorological network discussed in Paragraph 5-2b. Other types of data, while not strictly of a hydrologic nature, may also be required to monitor project regulation. These include spillway and outlet gate positions, power unit status, hourly power generation, navigation lockages, fish counts, and other water control parameters

that are involved in daily project regulation.

d. Water Quality Data

(1) Water quality data is essential for real-time water control management. Data collection programs are tailored to individual projects to meet water quality management objectives. Typically, data is needed for inflow, in-lake, discharge and tailwater stations to develop an understanding of cause and effect relationships. This in turn provides needed information for integrating water quality consideration into real-time water control management decisions.

(2) Water quality data collection involves field sampling and analysis, laboratory analysis and in-situ monitoring. Temperature, conductivity, dissolved oxygen, pH, turbidity and some parameters with very short sample holding times are measured in the field, and this data is immediately available for use in the water control process. Laboratory analyses for other parameters provide data that, once evaluated, are available for support of real-time water control management. In-situ monitors are used at projects requiring frequent water quality data for making operating decisions or to monitor their effects in terms of meeting operating objectives. Typical applications involve thermistor strings for measuring temperature stratification in a reservoir, an inflow monitor to detect acid slugs entering a lake and a discharge monitor for gaging results of operations. Monitors integrated into the Geostationary Operational Environmental Satellites (GOES) data collection network greatly enhance the ability to fine tune reservoir regulation to meet operational objectives.

e. Manual Data Observation

(1) Historically, manual observations of water control parameters represented the backbone of hydrometeorological systems. Even with more advanced systems, there may still be a need to incorporate manual observations into the networks. They may serve as backup to the automated systems and may also be necessary for observing hydrologic, project, or water quality parameters that cannot be feasibly automated. For some projects, it may not be economically feasible or desirable to construct, operate, and maintain an automated system. The Cooperative Reporting Network of the National Weather Service (NWS) has historically relied largely on manually observed and reported precipitation and water level amounts. This is particularly true for those observations by cooperative observers that report only when certain criteria of event magnitude are met. A goal of the NWS is to automate their cooperative network as quickly as resources will permit.

(2) Observers for field stations should be selected on the basis of reliability, and they should be properly trained to meet reporting requirements. For those projects that are staffed 24 hours per day, operating personnel are a source of reliable and current data. Specialized parameters related to water quality, fish movement, aquatic life, or other unusual parameters may require observations by technical experts specifically trained to make these observations.

(3) Manually derived data may be stored briefly in digital form in preparation for its subsequent transmission. This may be accomplished by data entry through local computer terminals, Personal Computers, or other digital data entry devices.

f. Automated Data Observation and Storage

(1) The first automated observation and storage capabilities at field sites used analog methods. At a water stage station this typically included a float system to drive a pen recorder. Such a system produced an automatic analog record of water levels. With the availability of digital technology the same sensing system was adapted to drive a punched paper tape to produce an automatic digital record. Other enhancements now commonly use the same float system to drive a digital shaft encoder whose output is stored in memory of a local microprocessor at the gaging site.

(2) Any mix of analog and digital sensor outputs may be stored at specified times to produce a history of past and current digital data at the site.

g. Installation and Maintenance of Data Collection Equipment

(1) Installation of Field Data Collection Equipment. Site selection is generally based on the location of existing USGS or other gages. The site should have a structure which can be used to house the monitoring equipment and the data collection platform (DCP). A DCP may include telephone equipment or a transmitter for communication via satellite, or both. The site should have commercial power or a solar panel as backup to the battery power. The total installation needs to be waterproof.

(2) Maintenance of Field Data Collection Equipment. The data from each site should be reviewed daily to determine if the data is correct and the DCP is transmitting. Each site should be on regular scheduled maintenance so that all equipment can be checked and

properly maintained. Each district should set up regular maintenance schedules. The following is a partial list of items which may be checked daily for each DCP.

- correct channel
- correct time slot
- battery voltage
- DCP transmit power
- modulation index
- signal to noise ratio
- limits within time slot
- error messages
- correct identifier
- valid data

These items can be checked from the review of error message reports prepared by the central receiving site operator.

### 5-3. Data Transmission

a. General. Single project river development systems, or multiproject systems which are relatively small and involve only Corps projects, require much less complicated communication and data handling facilities than large, complex river developments. Manually based and semi-automatic data handling systems may be entirely adequate for the small river systems, but handling data in this manner is generally cumbersome and inadequate for larger systems. The many repetitive transmissions from the data source to the data users, the time required for transmission, the chance of errors in repeated handling of data, and the inability to physically process the vast amounts of data from many different sources usually dictate the installation of an automatic data handling system. However, even with the installation of automated systems, there may still be a need for manual or semi-automatic data interrogation equipment to backup the automated systems and to provide an alternate method for users with less sophisticated needs to obtain basic river data. In this section, the means of transmitting data from field gaging sites (manual, semi-automatic and automatic) will be discussed.

b. Manual Data Transmission Systems. Current manually observed data are usually transmitted to water control managers by commercial telephone or by government operated radio or microwave voice systems. In a large river basin, the network may consist of several sub-systems, and data stations within a sub-system may be transmitted to data collection facilities at a project, sub-system field office, or local Weather Service Office. These offices, in turn, transmit the data to Corps of Engineers District Offices, Weather Service River Forecast Centers, or Weather Service River District Offices. The data may then be sent to the Reservoir/Water Control Centers or other water management element, by telephone. Hydrologic data from other federal government or state agencies may be similarly disseminated.

c. Semi-Automatic Data Transmission Systems

(1) Semi-automatic transmission systems are those systems that have automated part of the data collection function, but still require an individual to be present for complete functioning. An example of a semi-automatic transmission system still in use is the Telemark.

(2) Reporting hydrologic elements remotely by means of Telemarks was the first step in automating hydrologic reporting data networks. A Telemark is a piece of equipment that provides the means for interrogating a hydrologic station remotely without the need for direct observation by an observer. Interrogations are usually performed manually via telephone by someone at a data center, field office, project office, or river forecast center. While such systems depend upon individual interrogations, these may be made at regular intervals as required for routine operation. They can also be made at any time it is desired to monitor hydrologic conditions during floods or other emergencies. The Telemark equipment may be owned and operated by the Corps of Engineers, other federal agencies such as the Bureau of Reclamation, National Weather Service, and power marketing agencies, or state and local water divisions or bureaus. The use of the equipment and its interrogation by others is controlled by the agency who owns the equipment. Many radio based systems report data when they are interrogated.

(3) Retrieval of field station data using Telemarks is by land line equipment and normally through the existing commercial telephone service. Government operated communications systems can also be used when available. Telemarks that are connected to commercial telephone systems utilize a telephone coupling device (Codaphone), which permits automatic answering of incoming calls. Each field station or telemark is assigned a telephone number (often unlisted), which can



be called from any telephone set connected to the commercial telephone system. The manual interrogation of a telemark is interpreted by counting the audio "beeps" corresponding to the digital values of the measured element. Manual interrogation requires about 20 to 30 seconds for a 4-digit reading.

(4) Manual telephone interrogation of telemarks provides direct access to data from individual field stations, thereby avoiding the need to access a central database. For some users such as navigation companies, recreational boaters, irrigation operators, etc., this is particularly useful since they are generally interested in conditions only at a given site or limited reach of the river, as opposed to those responsible for river regulation who need ready access to information on the entire river system. Also, telemarks are easily accessed whereas access to central databases often requires some type of computer terminal. Interrogations by others must be controlled to prevent battery drain on battery operated telemarks and call overloading, which would affect normal operation of the equipment.

(5) Call up of Telemarks by data collection centers is now generally performed through use of computer terminals. These terminals can be programmed to automatically "dial up" the telemarks at preprogrammed times and in any desired sequence. They may also be used to interrogate individual telemarks on call if desired.

d. Automatic Data Transmission Systems

(1) General. In recent years, full automation of field station reporting has replaced manual and semi-automatic transmission equipment in many areas. Data transmission media that are available and being used are:

- ground based VHF radio
- environmental or general purpose communication satellites
- meteor-burst communication systems
- land line equipment utilizing hard wire or switched commercial telephone circuits
- general purpose microwave communication systems

In general, any or all of these types of transmission media may be used either singularly or in combination. Planning and design of a particular system must consider each of these alternatives prior to selecting the one or combination of them that best meets the overall requirements of the water control data system being designed.

Information on these transmission media and things to consider when designing a system using them follows.

(2) Ground Based VHF Radio

(a) VHF radio communication systems have been developed over a period of many years for automatic reporting hydrologic data stations. On site equipment for land based radio systems consists primarily of a radio transmitter and a receiver packaged in a container. The electronic equipment may also have some local intelligence and some storage memory. The receiver is designed to listen for messages/commands from a Data Acquisition Controller (DAC) and to respond accordingly by using the on site transmitter. Thus, either current sensor readings or data stored since the last transmission is sent to the DAC. DAC's are generally located at the project office responsible for data collection from a given sub-system.

(b) Radio frequency allocations for governmental use in reporting hydrologic observations are made in four bands in the 169- to 172-megahertz range and use of certain frequencies in the 406- and 412-megahertz bands. The use of these frequencies requires nearly a direct line-of-sight for transmissions between sending and receiving stations. For this reason, it is usually necessary to incorporate repeaters between the sending and receiving stations, particularly in mountainous regions. Repeaters are generally located on prominent high points in order to meet the line-of-sight requirements. Electrical power is required to operate this equipment. Power may be supplied from commercially available power lines if available, but frequently, these stations are located in areas not served by commercial power, and battery operated equipment must be used. Batteries used for this purpose may be recharged by solar cells, wind chargers, or automatically controlled small electrical generators.

(3) Satellite Communication Systems

(a) Satellites are currently in use to relay ground signals emanating from field hydrologic data gaging stations to a satellite central receiving site facility. Initial experiments were conducted in the New England Division using the LANDSAT polar orbiting satellites. When the Geostationary Operational Environmental Satellites (GOES) were launched in the mid-1970's, the Corps (Lower Mississippi Valley Division) started to use the Data Collection System (DCS) to perform this relay function. This has proven to be so successful and such a reliable means of obtaining data during severe weather conditions that the Corps has shifted dramatically to this system and is now the largest single user of the GOES DCS.

(b) The GOES satellites are operated by the National Earth Satellite, Dissemination and Information Service (NESDIS) of the National Oceanic and Atmospheric Administration (NOAA). This system is available to the Corps for transmitting environmental data. The major components of the DCS are the field gaging sites, the satellite, and direct readout ground stations (sometimes referred to as downlinks) located at central receiving sites for data retrieval.

(c) NESDIS operates three GOES satellites: the eastern satellite positioned at 75 degrees west longitude, the western satellite positioned at 135 degrees west longitude, and a spare satellite positioned at 105 degrees west longitude to serve as a backup for both the east and west satellites. The equipment located at the gaging station site necessary for the use of the GOES DCS is referred to as a Data Collection Platform (DCP). DCP's can either be of the interrogable type, where the DCP (site/gage) can be interrogated at any time, the periodic reporting type, where the DCP reports at regular intervals and specified times (self-timed type), or the randomly reporting type, where the DCP reports randomly within a specific time period that can be decreased by an algorithm programmed in the DCP as various thresholds are met or exceeded. An example of the random reporting system printout is shown on Table 5-1. Column 6 of the table shows the random time interval between transmissions. Dual channel DCP's can also be purchased where one channel is used in the self timed mode and the other channel in the random reporting mode. The majority of the DCP's purchased by the Corps since the advent of this option are the dual channel type.

(d) Several direct readout ground stations (central receiving sites) have been acquired by the Corps to receive Corps and other agency data. These are dispersed around the country in various District/Division offices. They are operated by Corps personnel or by others either through cooperative agreements or by contract. As the Corps system grows, additional central receiving sites will undoubtedly be acquired. In addition to the Corps central receiving sites, GOES data can also be retrieved from NESDIS or through other cooperative Federal or state owned central receiving site facilities.

#### (4) Meteor-Burst Communication Systems

(a) Meteor-burst communication systems use meteor trails in the ionosphere to reflect radio signals emanating from field gaging sites to a ground based receiving station. One rarely gets an immediate communications link when interrogating a field station or when a field station, through self timed response, is attempting to send its data to the central receiving station. A communication link

Table 5-1

Example Random Reporting System Printout (NED)

GOES RRDCS READINGS		DATE: 5/31/84		TIME 11:23								
		(1)		(1)								
NO.	NAME	D.A. SQ MI	M/D	TIME HR:MIN	DT HRS	STAGE FT	+/- FT/HR	Q CFS	+/- Q/HR	CSM Q/DA	STORM PREC.	NOTE
(2)	(3)	(4)	(5)	(6)	(7)	(8)	(9)	(10)	(11)	(12)	(13)	
38	WELLS RIVER	2644	5/31	4:55	7.3	13.73	.27	42574.	1020.	16.1		
36	WEST HARTFORD	690	5/31	7:39	1.1	11.23	.02	12894.	50.	18.7	4.34	WARN
35	WEST LEBANON	4092	5/31	6:00	3.3	20.21	.05	55166.	252.	13.5		WARN
37	NORTH WALPOLE	5493	5/31	7:36	.7	27.54	.10	32900.	468.	15.1		WARN
6	MONTAGUE CITY	7865	5/31	8:08	1.9	37.18	.13	135260	877.	17.2		FLOOD
5	GIBBS CROSSING	199	5/31	11:05	3.8	7.56	.05	4616	53.	23.2	9.00	FLOOD

EXPLANATION OF COLUMN HEADINGS

- (1) Date and time of the creation of this listing.
- (2) "NO." and "NAME" are data collection platform identifiers.
- (3) D.A. -- Drainage area at the data collection platform (square miles).
- (4) "M/D" stands for the month and day of the month of the latest message received. This item and item 5 comprise the time tag.
- (5) "TIME" is the hour and minute of the latest message (standard time).
- (6) "DT HOURS" is the time difference between the next-to-last and the last messages received -- used in the calculation of rates of change.
- (7) "STAGE FT" is the water level (pool or river stage).
- (8) "+/- FT/HR" is the rate of change of stage in feet per hour.
- (9) "Q CFS" is the discharge in cubic feet per second associated with the stage reported in the last message.
- (10) "+/- Q/HR" is the rate of change of discharge in cubic feet per second per hour.
- (11) "CSM Q/DA" is the discharge in cubic feet per second per square mile, otherwise known as 'csm'.
- (12) "STORM PREC." stands for inches of accumulated rainfall in the most recent storm.
- (13) "NOTE" heads a column reserved for comments regarding each message, such as nonvalid messages, flood stage, warning stage, or low battery.

is established only when the signal being transmitted has the proper reflection angle from the meteor trail to be picked up by the receiving station. This usually takes less than 2 or 3 minutes to occur.

(b) A meteor-burst communication system is used by the U.S. Soil Conservation Service, who operate the "SNOTEL" system used for transmitting snowpack and other hydrologic data from remote mountain locations in the western United States. Another meteor-burst communication system is used operationally by the Alaska District of the Corps of Engineers, together with other federal agencies operating in the State of Alaska, for obtaining hydrologic data from remote field stations.

(5) Land Line Data Transmission

(a) Land lines can provide a path for data transmission. They may be used for backup to critical sites that also transmit via GOES or other radio based system. In some geographic areas land lines may be subject to outage during hurricanes or other major meteorological events. Unfortunately, it is during such events that data transmission is most critical. Land line outages are being reduced and performance improved as wires are replaced by fiber optics and as lines are placed in conduits beneath the ground.

(b) The choice between a dedicated line or the use of switched public service should be based on the frequency of use, volume of use, cost and availability. Even if reliable public switched service may be functional during a flood emergency, the service may become overloaded by other users.

(c) In establishing land line communications consideration must be given to: transmission rate (110-9600 baud), mode (synchronous or asynchronous), protocol, error detection/correction and other issues. Different communications approaches may be appropriate when transmitting data from a field site to a host system, than would be used between two host systems.

(d) An automated data collection system now in operational use for hydrologic reporting networks by the National Weather Service is termed the Device for Automatic Remote Data Collection (DARDC). The remote station equipment produces serial ASCII code to represent in engineering units various hydrologic parameters, with 4 character identification and 4-decimal digit representation of each measured element. The field station equipment can be used in conjunction with the GOES DCS, with land line (or VHF radio communication) systems through which interrogations are made from a sub-system DAC. A more recent system now being developed by the NWS and TVA is termed the

Limited Automatic Remote Collector (LARC), which performs the same functions as the DARDC field equipment, but with added capability. The LARC system includes computer memory at the field station for storing current data, for the purpose of providing trends over recent time. The LARC equipment also provides both audio interrogation and computerized ASCII code.

(6) Microwave Communication Systems. Microwave communication systems provide a high capacity, line of sight, point to point, transmission path. Where microwave links have been established for other communications purposes, it may be possible to add real-time data communication at little additional cost. However, these communication systems are subject to outages during electrical storms and are generally considered less reliable than the more conventional means of water control data transmission.

(7) Communications Regulations. There are two regulations pertinent to the design and operation of the hydrologic data transmission systems that use the electromagnetic spectrum. ER 1125-2-308 describes requirements for the management of call signs and radio frequencies for data communication systems. ER 1110-2-248 deals specifically with data transmission via the GOES DCS.

#### 5-4. Decoding and Validating Transmitted Data

a. Information received from a data collection system must be decoded from the transmitted format. This operation may be different for each possible source from which data is received. After decoding into a standard form the data must be verified. Data received in a host system may contain errors introduced at any step from the sensing of the parameter to its receipt by the host equipment. Most common errors are associated with a failure of the sensing of the element. Water stage floats may hang up, precipitation gages may become fouled with foreign material, or maintenance personnel may reset a datum. Data transmission functions may introduce occasional random errors.

b. All received data should be validated before it is used to make water control decisions. Validation should include a range of possible checks. Simple checks should test data against an allowable range of values. Extended checks should test data against allowable rates of change for that parameter. Complex checks should test data by correlations with other stations and parameters. Where data fails to meet a validity check it should be marked as such, and if appropriate, a new value should be estimated. All actions must be clearly logged so the water control manager can accept or reject invalid, missing or estimated data.

5-5. Water Control Data Management and Processing

a. Data Storage and Retrieval

(1) A database is essential for the storage and retrieval of water control data. The database must provide for the storage of a variety of stations, parameters, and data versions, over various time intervals. New data received from the data collection network should be stored in the database. The database should also include forecast and project operation data.

(2) The database must be simultaneously accessible by multiple functions. Report generation, analysis tools and other routines must be able to retrieve data of both historical and real-time interest. Text products and non-numeric data must be included in a database for orderly storage and retrieval. This includes locally generated text reports, as well as reports received from other sources.

b. Water Control Database Management. Provision must be made for the management of the water control database. The water control manager must be able to control the amount of data that is available in the database. This includes the particular stations, parameters, time intervals and time duration. Data must be removed from the database on an established periodic basis. Removed data should be stored in an archive format which will allow its restoration many years in the future, if needed. The database must be capable of being edited to alter, add, and delete data values or entire data sets.

c. Data Interpretation and Displays. The data system must be capable of providing both graphical and tabular displays of information in the database. This includes any data received from the data collection system, or any data generated in the analysis of received data. The system should allow displays to appear on terminal screens, large screen display systems that may be utilized in briefing rooms or hardcopy device at user request. Text products must be displayable on these same devices as required.

d. Data Processing

(1) General. With the advent of real-time data collection, increasing water control management responsibilities, and decreasing manpower resources, computers are essential for data handling, manipulation and analyzing various project regulation schemes to accomplish the many tasks required of today's water control manager. These computers are generally located in District and Division

offices or maybe in a commercially available time sharing computer facility. The functional requirements for the computer can be such that they act as both a Data Acquisition Controller (DAC) and a data processor. These functions may also be divided either fully or partially between separate computers.

(2) Hardware and Software Requirements

(a) Hardware. The selection of the data processor used will depend upon the requirements that the processor must meet. Once the functions to be performed have been decided, the computer or computers chosen must be large enough and have sufficient data handling and analysis speeds to meet system requirements and the needs of the water control manager. The computer that performs the data handling functions must be a highly reliable system that is continuously on line to assure the dependable receipt and control of data inflow to the system. The computer that performs the data processing and analysis computations must provide the water control manager with answers in sufficient time to make real-time water control decisions.

(b) Loss of Commercial Power. Water control managers need to recognize the impacts and problems when the loss of commercial power affects communications and data collection activities. The need to install or develop emergency power facilities and uninterruptable power supply systems should be considered.

(c) Software. Development of system software must be designed knowing the type or types of hardware on which it will be required to run. The DAC must include appropriate software for data processing, storage and retrieval. The software design is highly dependent on the data system and processing requirements. Figure 5-1 is a schematic of an example water control data system showing acquisition, application and management software 2/. Water control data and application management software has been developed by the Hydrologic Engineering Center for Corps-wide use. (See References 3 through 6).

5-6. Coordination of Data Collection and Exchange

a. Interagency Cooperation

(1) Nearly all water control data systems require coordination with other agencies to collect the hydrologic data necessary for water control management. In addition to the Corps of Engineers



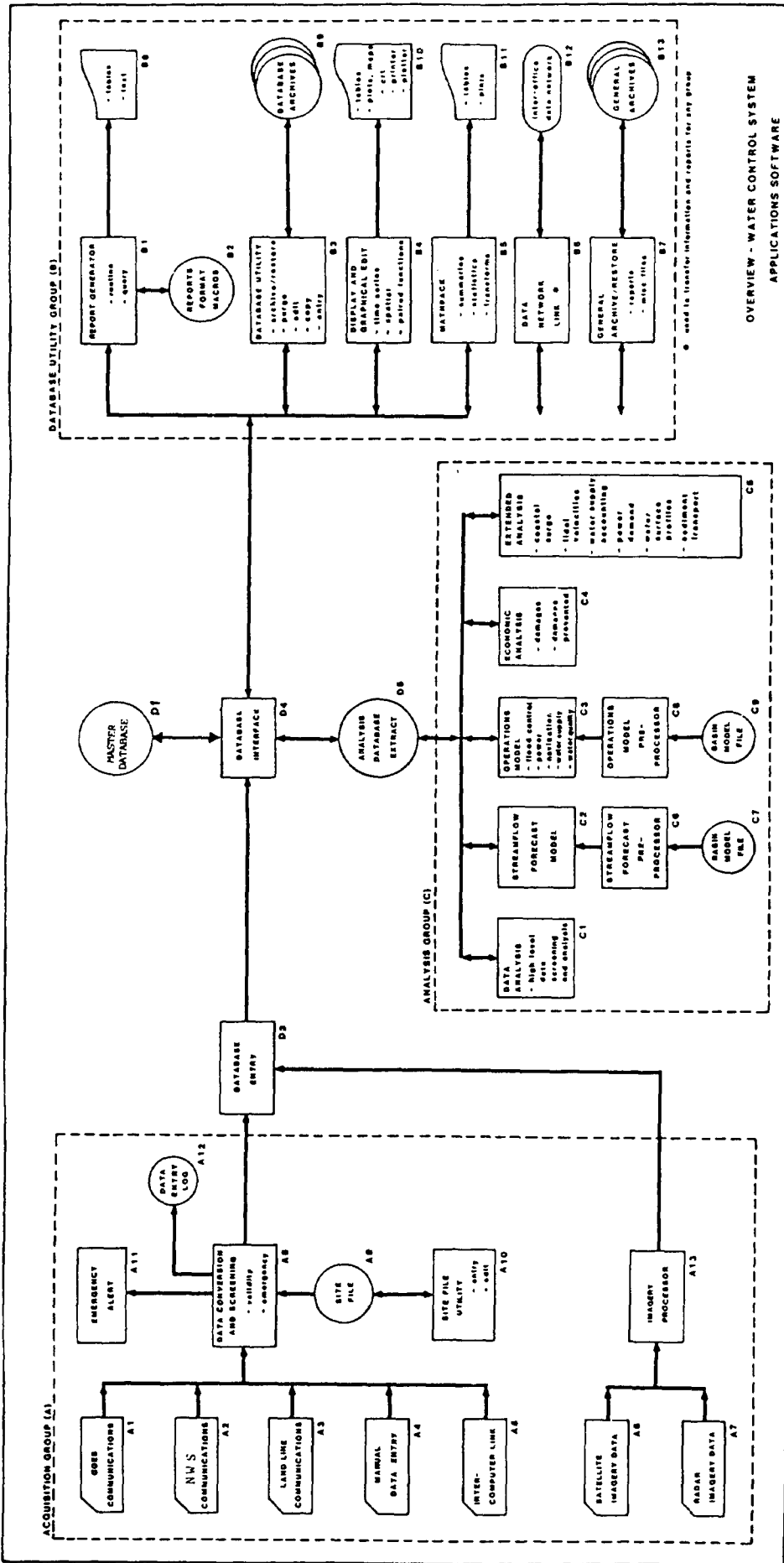

Figure 5-1

requirements, other Federal agencies have major missions that require them to also collect hydrologic and water control data. These agencies and the data they collect are listed below.

- (a) National Weather Service - Various hydrometeorological data from surface observations and satellite sensors.
- (b) U.S. Geological Survey - Water levels, streamflows, and water quality.
- (c) U.S. Soil Conservation Service - Snow water equivalent and related hydrologic parameters.
- (d) National Aeronautics and Space Administration - Data which expresses the areal extent of hydrologic elements such as snow cover, area of flooding, or soil moisture indexes as determined primarily from satellite measurements.
- (e) U.S. Bureau of Reclamation and Bureau of Indian Affairs - Hydrologic and water control data.
- (f) U.S. Department of Energy, through their Power Marketing Agencies (PMA's) - Certain types of hydrologic and power operational data needed for hydropower system operation.
- (g) Tennessee Valley Authority - Project related hydrologic, water control, and hydropower data.

(2) In addition to these agencies, state, local and private organizations may also obtain water control data needed for the operation of their individual projects. A wide range of water data systems coordination is accomplished through formal and informal operating agreements between agencies, at the national level as well as at regional and local levels. These cooperative programs have been entered into in order to avoid duplication of effort in the installation, operation, maintenance and funding of hydrologic reporting stations that meet both Corps of Engineers water control data requirements and the cooperating agency's needs. As described in Section 5-3, ER 1110-2-248 defines the requirements for coordinating water data transmission using the GOES DCS. Information Service of the National Oceanic and Atmospheric Administration. ER 1110-2-241 stipulates that the owner of this type of project will provide hydrometeorological instrumentation and communication equipment as necessary for real-time project regulation. Operating arrangements for the cooperative exchange of data between the Corps of Engineers and Federal agencies, as well as for state, local, and private entities, are generally made at the local level. Interagency coordination and/or operating agreements needed for the exchange of

water control data with other entities is normally included as part of the Master Plan for Water Control Data Systems.

(3) An example of basin-wide coordination of water control data collection and dissemination among a number of entities (Canadian, Federal and local) is the Columbia River Operational Hydromet Management System (CROHMS). This data system, which was an outgrowth of previous interagency coordination, was developed on an interagency basis, through the principles contained in a Memorandum of Understanding, signed in 1971 by six Federal agencies. The CROHMS data system is also utilized for the exchange of data between the United States and Canada, as required under the Columbia River Development Treaty of 1961. It provides data exchange among a large number of non-federal hydropower projects and a variety of other Federal, state and local interests. A summary of the design and operation of CROHMS is contained in References 7 through 9.

b. Operational Management of Cooperative Data Systems

(1) The operation of a cooperative water data system that includes several agencies and organizations must be managed in a manner which meets the requirements of each agency. While design and procurement of sub-systems is generally the responsibility of each individual agency, the melding of system requirements must be accomplished in a cooperative manner in order to assure the reliable and timely access to the system for each user.

(2) Limits may be placed on access to the system by those not party to the cooperative agreements, as indiscriminate use might overload the system. Problems associated with the design and use of the system as related to interagency activities must be resolved by interagency actions. Formal or informal operating agreements signed by all participating agencies help to resolve these problems as they arise.

c. Data Exchange

(1) Intra-Corps. Data exchange between Corps offices should make use of available data communications within the agency. Real-time data transfers should use dedicated communication circuits between District/Division offices. An economic analysis should be performed to evaluate when separate dedicated circuits would be appropriate compared with shared dedicated or switch (dial-up) circuits.

(2) Inter-Agency. Depending on the volume of data and relative location of each office, dedicated or switched circuits may be used for data transfers to other agencies.

(3) Format. For all intra-Corps and inter-agency transfers, the data should be transferred in an approved standard format. The current adjusted format for such data transfers is the Standard Hydrometeorological Exchange Format (SHEF).

## CHAPTER 6

### WATER CONTROL ANALYSIS TECHNIQUES

#### 6-1. General Considerations

a. Importance of Technical Evaluations. Effective regulation of a major water resource system in real-time ultimately depends upon the experience and judgment of the water control manager. Complex interactions among the many meteorologic and hydrologic processes, combined with the effects of project control, encompass a wide spectrum of continuously changing conditions which must be evaluated and understood. Judgmental decisions made by the water control manager must be founded on the best available scientific and engineering evaluations, considering time constraints and available data. There are many analytical tools now available that may be used to quantify those elements which would otherwise be subjectively determined. Accordingly, it is the overall objective to perform technical evaluations based on rigorously defined analytical procedures, rather than subjectively determined estimates. The technical methods used in analyzing water resource systems are of prime importance in the overall accomplishment of water management objectives. They constitute the technical support by which the water control manager may form decisions during actual project regulation.

#### b. Hydrologic Analysis - Historical Data

(1) One of the primary technical problems in managing water control systems in real-time is hydrologic analysis. Water is the prime resource to be managed in water control systems, and this demands full knowledge of the natural processes by which water is distributed and accounted for in a river system. The science of hydrology is defined as the body of knowledge related to the behavior of water as it occurs in the atmosphere, on the surface of the ground, and underground. Although hydrology is considered to be a science, there is a blending of scientific theory and empirical knowledge in the application of hydrology to the analysis of river systems.

(2) For many years, the Corps of Engineers has utilized widely accepted hydrologic analysis procedures in design flood hydrology. Specific reference is made to Chapter 5 of EM 1110-2-1405 for a discussion of factors to be considered in determining the magnitude of design floods. Application of these principles was extended to rivers affected by snowmelt runoff and is described in EM 1110-2-1406 and Chapter 10 of "Snow Hydrology" 10/. Initially, these methods were used for project planning and design studies, but more recently

they have become the basic method of analysis for project operation and real-time project regulation. During the past 3 decades, detailed methods of analysis have been refined through continued development and application of computerized procedures for analyzing runoff.

(3) Long-term analyses of river and project conditions are based on historical or derived streamflows that are used in connection with the development of water control plans. Simulations of project regulation are computed by system analysis techniques that will portray river and reservoir conditions for an extended period of time, based on current reservoir conditions and historical streamflow data. Thus, this type of simulation may be made to test the system's capability to meet its water demands over a long period of record (30 to 50 years), based on current project conditions, recent operating criteria, and historical streamflow data. Simulations of project regulation may also be made that consider each year of historical record as an individual event. This is useful in obtaining a probability distribution of project regulation conditions during the ensuing year or a portion thereof, in order to assess the probabilities of meeting water demands based on historical records of streamflows, current reservoir levels, and water or power demands.

(4) In summary, the overall objective in analyzing water control systems in real-time is to use all the current water control data available to apply the analytical procedures necessary to regulate projects in the most effective manner possible. This will provide information to schedule the regulation of individual projects and to obtain outlooks of future system regulation. Project regulation schedules must be generalized since they are based on historical data and hindsight operation. When plans are applied in real-time, however, operational decisions need to be made under the guidelines of the water control plan, but adjusted as necessary to meet any unique conditions.

## 6-2. Computer Utilization for Water Management

### a. Basic Principles

(1) Computers are now an accepted means for problem solving generally throughout the Corps of Engineers. Computers are used to solve engineering problems encountered in planning, design, and construction of water control systems, and this is especially true in the fields of hydrology, hydraulics, and water management. Computers were first applied to water management problems in the mid-1950's, in connection with application to hydrologic simulation and reservoir system analysis. The expansion of techniques has continued since

that time, paralleling the expanding technology of data processing systems. Now a major array of hardware and software systems are fully developed and available for general use. Furthermore, engineers are now trained to utilize these systems, and they are accustomed to solving the data handling and analytical problems that these systems present.

(2) Initially, these computerized hydrologic and system analysis techniques were applied to planning and design functions, but there were also major efforts to develop the techniques for real-time project regulation. As a result, there has been a steady refinement of the programs and models that can be applied to water management activities, and this will continue into the future as the technology and data systems improve.

b. Concepts in Computer Utilization

(1) In hydrologic simulation and reservoir system analysis, the computer provides a means for data processing and problem solving that would otherwise be completely infeasible. The continuous simulation of water resource systems for a major river basin requires large amounts of data and computational power, as well as data processing systems that are convenient to the user, in order to apply the procedures to real-time water management. Therefore, the design of these systems must be oriented with this basic concept in mind. One of the major design factors for real-time analysis is to provide a system that can be used with a minimum time required for input data preparation, data handling, and interpretation of output. Furthermore, the algorithms that express the hydrologic functions affecting streamflow must be based on sound hydrologic theory, but they must also be practical representations of hydrologic processes considering the availability of basic data, quality of the data, and data processing requirements.

(2) These programs constitute tools that can be used by the water control manager to enhance technical knowledge of water conditions within the system. Improved water control decisions and detailed schedules can be made as a result. In summary, computer evaluations should be considered only as an analytical tool by which the water control manager may conveniently test various alternatives and conditions affecting regulation within the framework of the water control plans.

c. Types of Models

(1) The types of models which may be applied to real-time project regulation may be generalized into the following groups:

(a) computer models used to simulate hydrologic processes and thereby synthesize streamflow, in order to forecast flow resulting from rainfall or snowmelt estimated from known hydrologic conditions and forecasts of future meteorological events;

(b) reservoir system analysis models used to simulate single or multipurpose projects, based on observed or derived streamflows, in order to determine future project capabilities from known river and reservoir conditions;

(c) reservoir water temperature and water quality models used to simulate the conditions of water quality in a reservoir and at downstream locations for assessing future conditions of water quality and scheduling the operation of multilevel outlet works or other facilities related to water quality control at the projects;

(d) water supply and forecast models used to forecast seasonal runoff, based on statistically derived procedures using indexes of hydrometeorological variables;

(e) special auxiliary programs used to determine water release schedules, summarize data, display data, and analyze particular functional needs that affect water regulation.

(2) A brief description of commonly used computer programs that perform many of the described functions is included in Appendix C, EM 1110-2-1701. References 11 through 16 give detailed descriptions of several application programs.

### 6-3. Meteorological Forecasts Used in Water Control Management

#### a. General

(1) River system response is ultimately the result of hydrometeorological factors that affect runoff. The time, form, and areal distribution of precipitation, together with meteorological factors that affect energy inputs that cause evapotranspiration and snowmelt, are controlled by meteorological processes in an ever-changing atmosphere. The analyses in the preceding sections are concerned not only with the current conditions of hydrometeorological factors affecting runoff, but also with projections of these conditions into the future. For this reason, meteorological analyses are an important consideration in making forecasts and projections of project regulation, and the water control manager should have basic knowledge of weather-related phenomena, both physical and statistical.



(2) All streamflow forecasts must make some specific assumption regarding additional meteorological input during the forecast period. These expectations may be based on subjective evaluations made from cursory examinations of current weather data, or by detailed analyses and forecasts that quantify the expected precipitation, air temperature, wind, humidity, solar radiation, and other factors that affect the hydrologic balance during the forecast period. Basic weather forecasts are prepared nationally by the National Weather Service (NWS). The basic weather data and national analyses are available to Corps offices through direct computer connections, telecommunication systems, and charts and maps. Local or regional analysis may be done by the local offices of the Corps or through cooperative arrangements with the NWS forecast offices.

(3) Analyses may be performed to provide a family of forecasts covering a range of future meteorological conditions. Application of weather data beyond the time range of reasonably accurate weather forecasts requires additional special weather analyses for use in water management activities. Assumptions must be made for input to computerized streamflow simulations for medium- or long-range projections of streamflow or weather related variables that will best represent the most likely occurrences of these elements. Such assumptions may be based on single valued climatological averages or multivalued statistical arrays, which can be used to represent the statistical variability of future runoff events. These analyses may be used to determine not only most likely projections of future runoff and project conditions, but also extremes that may occur under unusual circumstances. This type of analysis is of particular importance to the water control manager who needs to know the potential for controlling future flood events that may occur, or for assessing the potential for low-flow or drought conditions, based on current hydrometeorological and project conditions.

b. Short-Term Weather Forecasts

(1) Quantitative Precipitation Forecasts (QPF). One of the more important types of weather forecasts for project regulation is the Quantitative Precipitation Forecast (QPF). Normally, weather forecasts are performed by the NWS, either in conjunction with their National Weather Forecast Center or through state Weather Service Forecast Offices. The NWS Quantitative Precipitation Branch in Washington, DC, prepares a daily national map showing isohyetal lines of 24-hour QPF for the country as a whole. This information is transmitted on the NWS Automation of Field Operations and Services (AFOS) network and is available to Corps offices as a program licensed by the NWS. The AFOS system replaces the facsimile system previously used. The national QPF map is generalized and does not

provide detailed information required for individual projects or river systems. More detailed analyses and forecasts may be made at the local or regional level. This may be accomplished through cooperative programs with the NWS State Forecast Offices or River Forecast Centers or by meteorological specialists within the Corps. QPF's may be developed as 6-hour values for specified locations or drainage basins, for 2 days in advance, and for a 24-hour value for the third day.

(2) Air Temperature Forecasts. Air temperature is important to hydrologic forecasting for differentiating the form of precipitation as rain or snow, and as an index to snowmelt rates, where snow is a significant contribution to runoff. The weather analyses required for QPF may also be used for determining forecasts of air temperature. The forecasts are usually specified as maximum daily, minimum daily or period-by-period air temperature values for index stations. Closely allied to forecasts of surface air temperatures are forecasts of upper air conditions at particular atmospheric levels, freezing levels, or melting levels. Forecasts of this type are particularly important for determining the areas of rainfall and snow accumulation in mountainous regions.

(3) Forecasts of Snowmelt Runoff Parameters

(a) Hydrologic forecasts for those rivers that are fed at least in part by snowmelt runoff need weather forecasts of appropriate snowmelt parameters. Evaluations of snowmelt runoff are very complex from a theoretical point of view, and considerable research effort has been made to determine the relationships between meteorological parameters and snowmelt runoff (see Reference 10 and EM 1110-2-1406).

(b) Weather forecasts required for snowmelt runoff forecasting are generally confined to forecasts of air temperature. Forecast air temperature are used as indexes for snowmelt. The air temperature forecasts may be either maximum temperature, mean temperature, or a combination of maximum and minimum temperatures. Under some circumstances other parameters may be included in determining snowmelt indexes, such as dew point, relative humidity, wind, or solar radiation 10/, but these are not generally used in operational forecasting.

(4) Weather Forecasts for Tidal Barrier Regulations

(a) Hurricanes. Engineering Manual 1110-2-1412 provides guidance for storm surge analysis and design water level determinations in coastal areas. The factors affecting operations for a hurricane are its forward speed as it moves toward a project and the track of the storm center as it approaches the coastline.

Speed of the storm, which often accelerates as it moves into the northern latitudes, affects the time permitted for mobilization, closure of gates and general preparation for the tidal surge. Location of the storm track relative to a coastal community influences the magnitude of the surge. All hurricanes and other cyclones in the northern hemisphere rotate in a counterclockwise direction. Winds are highest in the right side of these storms, and storm surges will be highest in this side since winds will be blowing on shore. Therefore, when the storm center passes to the left of a project, the project will be susceptible to the worst effects of the hurricane. The components affecting storm surge consist of the forward speed of the storm, hurricane wind speed, and low barometric pressure. All of these components are additive. Such conditions may cause abnormally high tides and waves that are often intensified at the head of coves and bays. It is not yet possible for the National Weather Service to predict with a high degree of reliability whether the track of a hurricane, possibly several hundred miles away, will pass to either side of a community. Thus, in operating a hurricane project, it is necessary to assume that mobilization of personnel and closure of gates will be required. It is anticipated that some of the storms, for which preparations have been completed, will veer away and produce no appreciable tidal surge.

(b) Extratropical Storms. Extratropical storms also produce abnormal tides above damage stages; for these storms, operation of a barrier is dependent upon the wind speed and direction as well as the predicted tide and estimated surge. From past studies and operating experience, it is evident that highest abnormal tides during an extratropical storm nearly coincide with the time for a predicted astronomic high tide (within 1 to 2 hours). Therefore, the time of operational requirements can be more readily predicted than for a hurricane. However, slow moving extratropical storms often produce abnormally high levels for several consecutive tide cycles, which may require more than one operation of a barrier.

(5) Severe Weather Forecasting. Beyond the activities involved in management of water control systems, the Corps of Engineers needs real-time weather forecasts in connection with the operation of its floating plant and field installations. Forecasts of anticipated severe weather (primarily wind and storms, but including other unusual weather conditions) are required to meet not only the needs in connection with operation of water control projects, but also for the safe operation of all land based and floating equipment. Inasmuch as liaison between the National Weather Service and the Corps of Engineers is maintained through those elements of the Corps dealing with water management activities, weather forecasts for general use within Corps activities are supplied through the appropriate water management, reservoir control, or water regulation

units within the Division or District offices.

c. Long-Range Weather Forecasts. Long-range (monthly, seasonal, or annual) weather forecasts are considered to be experimental. Their accuracy, when compared to the use of statistically derived climatological averages, does not warrant their application to management of water control systems. The water manager should be cautioned not to place a "partial" trust in long-range weather forecasts for "shading" project regulation criteria in response to such projections. An unjustified use of such forecasts may, in the long run, result in misregulation of project facilities and under extreme conditions, jeopardize the authorized functional use of the projects. Monthly weather outlooks do show some relatively modest degree of forecasting skill in comparison with using climatological averages of historical data.

#### 6-4. Simplified Manual Methods for Analyzing River Response

a. Backup Procedures. Manual analytical procedures may be required to assure continuity of project regulation. Simplified analytical techniques should be available for use by field or project offices in the event that communication is lost between the control center and the projects. For these reasons, generalized manually applied aids should be developed which can be used in an emergency. These would be simplified index procedures or graphical relationships that can be used to estimate runoff conditions from whatever data may be available. They may also be guides for project regulation as determined from known project inflows or other water control data. These aids or guides may be developed from analyses of historical data, and they may also be derived through use of the computerized methods for simulating hydrologic conditions and project response.

b. Graphical Runoff Relationships. A particularly convenient and useful method for deriving multivariable graphical aids for estimating runoff is based on the use of calibrated hydrologic simulation models. As a study program, the forecasting diagrams are derived by simulating the runoff processes for a range of conditions, including variable amounts of rainfall and variable initial conditions of the basic soil moisture and base flow infiltration indexes. This information can be generalized into linear or curvilinear relationships as multiple-function co-axial diagrams. Forecasting diagrams of this general type have been developed for use in operational forecasting (see Linsley, Kohler, and Paulhus, "Hydrology for Engineers" 17/), based on observed conditions of rainfall and runoff that have been correlated with computed runoff index values, as, for example, the Antecedent Precipitation Index API method. The use of a computer simulation model in developing these

relationships has a particular advantage over the use of observed data since the various ranges of values for each of the runoff indexes and rainfall amounts may be tested as individual parameters. Thus, a series of simulation runs covering all ranges provide an array of data which can conveniently be put into a graphical relationship, whereas the use of historical data is limited by the ranges and amounts covered in a relatively small sample of hydrologic events. Further, a procedure that is based on runoff characteristics derived from multiyear calibration studies for streamflow simulation models provides better evaluations of runoff potentials than less rigorously determined correlation techniques.

#### 6-5. Long-Range Predictions of Streamflow

##### a. General

(1) Up to this point the discussions of streamflow analysis and related weather forecasts have dealt with short-term outlooks covering a few days, or extended to a few weeks as medium-range projections. There is a need, however, to consider long-range predictions of streamflow which cover periods of several months in advance of the date of forecast. As indicated in Paragraph 6-4c, long-range weather forecasts can be considered at this time only as experimental and not of sufficient accuracy for application to real-time project regulation. The interrelationship of hydrometeorological factors affecting runoff imposes similar restrictions in long-range streamflow forecasts, but there are some hydrologic factors having carry-over effects which provide the ability to develop useful and reliable long-range streamflow forecasts. Situations for which long-range streamflow forecasts may be significant are described in the following paragraphs.

(2) For rainfed rivers, these effects are limited to long-term changes in ground water conditions that may be determined at a particular time and projected into the future as a basis for long-range streamflow forecasts. The accuracy of such forecasts limits their use to assessing general trends in low-flow conditions of runoff that may have significant effects on project regulation for hydropower or water supply functions. These long-range streamflow forecasts for rainfed rivers would have little or no significance to flood regulation.

(3) The runoff from predominately mountain snowfed rivers, on the other hand, may be forecast several months in advance on the basis of known conditions of the accumulation of the snowpack over the watershed. In general, the snowpack accumulates progressively through the winter season and then melts in the late spring or early

summer. The knowledge of the water equivalent of the snowpack provides as much as 4 to 6 months advance notice of the expected runoff volume. Forecasts based on this knowledge are extremely useful in managing project regulation for all purposes, including water supply, irrigation, navigation, flood control, hydroelectric power, fish passage, recreation, and other environmental functions. Long-range forecasts of snowmelt runoff provide a direct measure of the volume of runoff to be expected in the runoff period, but they do not forecast the time-distribution of runoff. Factors affecting daily snowmelt are related to weather parameters that cannot be forecast on a long-range basis.

b. Statistical Procedures for Forecasting Seasonal Snowmelt Runoff Volume

(1) There is a long history in the development and application of procedures used for forecasting seasonal snowmelt runoff volume. This development has occurred mostly for the rivers of the mountainous West, in connection with regulation of multipurpose projects, and for management and forecasting of uncontrolled rivers as related to irrigation developments and flood control needs. Some of the principles involved in these methods have also been applied to rivers in the Northeast, Middle West, and Alaska. Nearly all of the procedures are based on the use of relatively simple month-to-month indexes of snow accumulation and precipitation. Refinements in procedures are made through use of indexes of other factors involved in the water balances of the areas, including soil moisture increase, evapotranspiration, and changes in ground water storage. The forecasting relationships are derived either by graphical analysis or by mathematical statistical correlations of runoff with single or multivariable indexes. This type of analysis generally utilizes the multiple linear regression technique, applied to historical data of runoff and index parameters. Some procedures transform the variables logarithmically or exponentially, whereby the correlations become curvilinear rather than linear. Although nearly all procedures are based on statistical analysis of simplified indexes of runoff, some attempt has been made at a more rigorous water balance approach to seasonal runoff forecasting.

(2) Chapter 11 of "Snow Hydrology" 10/ presents a summary of methods used in developing procedures for forecasting seasonal snowmelt runoff volume. It describes the index and water balance approaches and discusses at length the various indexes that may be used. In summary, the main emphasis of procedural development is to use rationally based indexes that represent the water balance of the area involved. The primary index is normally that of snow accumulation, which may be represented by direct measurement of snow accumulation at snow courses or by indirect measurements of seasonal

precipitation at selected climatological stations.

c. Use of Deterministic Hydrologic Models for Long-Term Streamflow Forecasts

(1) A logical extension of the use of deterministic hydrologic models is their application to long-term streamflow forecasting, as an alternative to the use of statistically derived forecasting procedures. The principle objective in formulating statistical procedures for forecasting seasonal snowmelt runoff volume is to select indexes which are most highly correlated with runoff and are also representative of the physical hydrologic processes defined by the water balance of the area involved. Although the lumped hydrological parameters used in deterministic simulation models are also considered to be indexes of the hydrologic processes, they represent an average basin or zonal value of these processes, as best estimated from a large array of available data. The model simulation is considered to represent the water balance of the area involved. The models are rigorously applied in daily or smaller time increments to best represent the physical processes of snow accumulation, snowmelt runoff, and all other hydrologic processes involved in the water balance of the area.

(2) Deterministic hydrologic models not only can incorporate all of the data used in statistical procedures, but also can utilize additional data that pertain to evaluations of snow accumulation and other hydrologic processes, and thereby better represent the true determination of those factors that affect future runoff. Therefore, deterministic models account for the processes in daily or smaller time increments and provide a much more rigorous analysis of runoff events than can be done by monthly based statistical methods. Further, the fact that the application of this type of model allows for maintaining daily continuity of all hydrologic parameters in a forecast mode permits a continuous appraisal of runoff conditions for operational forecasting in a way that is completely infeasible with statistical models developed from monthly data. This is particularly important for appraising changed conditions of runoff potential at any time within the month-to-month forecast evaluation period commonly used with statistical procedures. These procedures also allow for rational determination of the effects of an array of assumed weather conditions subsequent to the date of the forecast; examples are median, mean, percentile of exceedence, or extremes. For these reasons, there will be a gradual transition from the use of statistically based procedures for forecasting seasonal snowmelt runoff to procedures based on the use of deterministic hydrologic models.

## 6-6. Long-Range Analysis of Project Regulation

### a. General

(1) Long-range analysis of project regulation may be necessary on a current real-time basis in order to assess the planned regulation, beginning with currently known project conditions and with knowledge of current regulating criteria, which may include revisions to the generalized criteria contained in the water control plans. Projections of this type are used primarily in connection with analyzing project regulation requirements for hydropower, water supply, or environmental considerations. Examples of revisions to water control criteria would be changed hydropower requirements caused by revised load estimates or unplanned plant outages, special requirements for preserving fish runs, or other functional or environmental needs that arise on a current basis that were not anticipated in the water control studies.

(2) As discussed in Chapter 3, development of the water control plan involves a lengthy process of studying project regulation from the planning and design stages to preparation of the regulation schedules and their documentation in the water control plan. Further, an annual operating plan may be developed that applies the regulation principles contained in the water control plan to the current year's regulation. The regulation would be based on assumed hydrologic and project conditions, which may depart significantly from actual conditions. Accordingly, there is a need to re-evaluate the current regulation as conditions change from those contained in the water control studies, in order to reflect the effects of the current operating experience on future regulation.

b. Analytical Techniques. The methods used for this type of analysis are essentially the same as those used in developing the water control plans, but there may be some modification in the methods of application of those techniques. Thus, the concept of computerized reservoir system analysis, which is fundamental to planning system regulation, can also be applied to current regulation of a system of multipurpose projects. The analyses used to develop water control plans and simulation models that can be used are discussed in Chapter 3.

c. Basic Data and Types of Analyses. Long-range analyses normally cover the current year's operation, but in situations where there is planned use of reservoir storage over a multiyear critical period, the projections may be extended over a 2- to 3-year period. The hydrologic data used as input for current system analysis studies are the same historical mean monthly streamflow data used in water control studies, but there may be a minor modification of streamflow



data to reflect a transition from the currently observed streamflow conditions to the historical data. The historical streamflows can be analyzed to represent the effect of the most critical streamflow sequence on system regulation, a statistically derived sequence of streamflows representing median or mean conditions, or an analysis of the entire historical record as a continuous process to determine the long-range effects of future system regulation based on the most recent data. Also, it may be desired to test the current year's regulation by analyzing system regulation for each individual year's historical streamflow data as an independent event, commencing with the current project conditions, and thereby obtain a statistical distribution of future probabilities of all of the elements of system regulation for the remainder of the operating year.

d. Utilizing Results of Long-Range Analysis

(1) The long-range analyses of system regulation as discussed above have their greatest significance in assessing low-flow water supply and hydropower capabilities. Specifically, they provide the technical evaluations necessary for optimizing power production, for determining the strategy for marketing surplus power, for assessing probabilities of meeting firm power commitments, and for determining the probable effects of power operation on nonpower functions. The same principles of analysis may also be applied to assess future conditions of regulation as related to other project functions, such as irrigation, water supply, recreation, fish and wildlife, and other environmental uses. Thus, by maintaining continuity and surveillance of system regulation, long-range analyses provide the water manager with the ability to anticipate future conditions that may be adverse to meeting the overall water management goals and to take appropriate corrective action in time to be effective.

(2) In summary, real-time long-range projections based on monthly reservoir system analysis techniques are used primarily as an aid in regulating large multipurpose reservoir systems. The importance of such analysis depends on the particular hydrologic and project conditions that are being experienced. Under near normal streamflow conditions, with no significant changes in the operating criteria from those contained in the operating plan, and with no special problems related to system regulation, there may be little need for this type of analysis. On the other hand, unusual circumstances often occur that require careful study to determine the future consequences of project regulation. Any modification of the planned regulation to meet such circumstances does indeed depend upon these types of long-range projections, and reanalysis on a monthly or weekly basis may be required.

## 6-7. Water Quality Forecasting

a. General. Up to this point this chapter has dealt with water management techniques that are geared basically to managing the quantity or potential quantity of water in a river-reservoir system. There are many environmental impacts that are attributed to Corps water control projects, and some are quite significant. It is essential that the water control management team recognize and address to the fullest the environmental potential of each project or system of projects they manage. This awareness comes from a team approach, blending and balancing a wide range of disciplines which should include hydraulic engineers, water chemists, biologists, and whatever other specialty the particular system warrants. These team members must be part of the real-time operation of the projects. It may not be sufficient to leave the day-to-day decision making to the hydraulic engineer alone since this process often offers the best opportunity to generate environmental benefits from water control projects. Many situations and opportunities arise in real-time water control management that can only be recognized by specialized team members. Several important aspects of water quality management of Corps projects are forecasting future quality, evaluating existing quality, and predicting the effect of various management options on the projects and the areas influenced by the projects. There are several analysis and forecasting techniques available.

b. Analytical Techniques. Analytical techniques used vary widely but follow the same general types of analysis that are involved in weather, flow, and volume forecasting. These analyses may involve computer simulation of historical records to evaluate various management options for planning purposes or be models of real-time, existing conditions that allow tests of a variety of management choices on present and future water quality conditions.

### c. Forecasts

(1) General. There are many aspects of water quality that may need forecasting. Some of the more typical parameters are temperature, dissolved oxygen, turbidity, nutrients, sediment, pH, dissolved solids, algae, fish migration, metals, and contaminants. It may be necessary to establish long-term cycles of some parameters such as temperature to evaluate the impact of various operating scenarios on the project waters and on the downstream zone of influence. In other cases it may be important to forecast short-term factors, such as the passage of an "acid slug" in a stream influenced by mine drainage, and develop real-time response to deal with it. Water quality forecasting is usually the sole responsibility of the water control manager, and he must decide what to forecast, how to forecast it, and how to use the forecast in his decision process.

Some reservoirs have long memories, and management decisions made today may have an impact that will last for years. It must be understood that long after the physical and chemical effects of a management decision are gone, the biological consequences may linger for weeks, months, or years depending on the project and conditions around it.

(2) Long-Range Forecasts. Long-range forecasting of water quality should include projection of conditions as far in the future as is practical and useful to project management decision making. Reasonable forecast computer models for many physical and chemical parameters can be used to estimate weeks and months ahead. Long-range forecasting can also be much less sophisticated, utilizing a graphical evaluation and projection of conditions. EM 1110-2-1201 is a good reference for analytical techniques. Long-range forecasting is usually important to large projects with longer retention times.

(3) Near-Term Forecasts. Near-term forecasts are those that evaluate or forecast for only a few days or, at most, a week or two. These forecasts are used to evaluate real-time conditions and project management alternatives that do not have far reaching consequences and may be especially useful for managing small projects. Near-term water quality forecasts should always be made to evaluate the consequences of possible project management alternatives prior to making a decision. These decisions may be as simple as changing a port in a selective withdrawal tower or decreasing a release to stabilize a pool level. Each decision in one form or another is based on a forecast. Decisions should not be based solely on a flow forecast but also include a quality forecast to determine if there are better alternatives and how it may be possible to control the environment of the project in a more positive manner.

## 6-8. Special Hydrologic Analyses

### a. General

(1) There are many other special types of analyses that deal with specific hydrologic problems, including:

- determination of streamflows and water level in a major river which incorporates diversion structures in the control of water levels (e.g., the Lower Mississippi River), where the determination of unsteady flow conditions within the confines of the river itself is the dominant hydrologic problem
- behavior of rivers and reservoirs under conditions of ice and

sedimentation, and their effects on projects, project operation, channel capacities, and flooding along the rivers

- effects of winds, storms and tides on water levels in rivers, lakes, and estuaries, together with their effect on determination of project inflows
- determination of reservoir evaporation and its effect upon regulation
- determination of effect of bank storage on reservoir capacity
- changing effects of forest removal and urban development on runoff

(2) The above list indicates only the more general types of hydrologic problems that are encountered during water management activities, and each river system has its own set of problems which may involve many other facets of hydrologic analysis. The particular analytical methods for solving these problems are usually developed by the operating office in which they occur, and their use is usually limited to their particular areas of application. The following paragraphs summarize briefly some of the specific problems and methods that have been developed for solving these problems.

b. Unsteady Flow Determinations in Major Rivers. There are many methods commonly used for simulating the response of river systems subjected to unsteady flows. Streamflow routing procedures range from simple, empirical methods for translating and computing the attenuation of the unsteady flow fluctuations, to highly complex and completely rigorous computerized solutions of the unsteady-state flow equations. Each has its use for particular types of applications, depending on the type of river system, the general ranges of flow variations normally experienced, the effects of variable backwater conditions caused by tides, project operation, or "looped" ratings of channel flow, the overall accuracy of the computed fluctuations in relation to the needs for a particular application, the time and effort that can be expended in the solution for timely use, and the availability of basic data required for application.

c. Effects of Sedimentation in Rivers and Reservoirs. Sedimentation has long been an important aspect of planning and designing projects. In the operational phase of water resource development, recognition must be made of the potential problems that may develop as the result of sediment deposits in both reservoirs and natural stream channels. The problems may involve the loss of active storage space in reservoirs, changes in channel characteristics and

sedimentation balance for rivers downstream from projects, effects of sediment deposits in small tributaries entering reservoirs, changes in maintenance dredging resulting from water control, and the lack of knowledge of sediment density currents in reservoirs. These effects relate to water management activities in relation to changing conditions for downstream control, managing water levels, and controlling the regulation of multilevel intake structures or other outlet facilities.

d. Effects of Ice in Rivers and Reservoirs

(1) The occurrence of ice has major significance to management of water control projects in the northern tier of states and Alaska. River ice forms in the fall or early winter and may gradually increase in thickness until the spring thaw. River ice may constitute a major threat for flooding as the result of ice jams that build up at critical locations, especially at the time of the spring thaw or at other times when streamflows increase and the ice jams severely restrict the flow of water in the river channels. The prediction of the occurrence of ice jam flooding is particularly important where it may involve the release of water from upstream reservoirs. Ice jams are also likely to occur where tributaries enter reservoirs. This is mainly the result of reduced channel velocities in the river immediately upstream from the reservoir. This type of occurrence may require special regulation of the water surface in reservoirs to help mitigate adverse effects in the upstream tributaries. The occurrence of ice in river channels also affects the flow rating relationships used for determining streamflows from reports of water levels, and special efforts must be made to properly apply rating curves under these conditions. Formation of ice in reservoirs is common in cold climates, and ice cover may persist for as much as six months, with thicknesses up to three feet. The occurrence of ice on large reservoirs is of concern in the vicinity of the dam or control works, or as it may affect navigation. Ice flows caused by wind may build up in reservoirs in the vicinity of the dam and could impair the operation of outlets, spillways, navigation locks, or other facilities. In cold weather, spillway gates are susceptible to freezing, which may restrict their normal operation, unless specific measures such as seal heaters are incorporated into the design. The occurrence of frazzle ice in penstocks may also restrict the operation of hydropower facilities at certain times.

(2) The U.S. Army Cold Regions Research and Engineering Laboratories (CRREL) have made extensive investigations of the formation and movement of ice in river channels, lakes, navigation locks, and other water control facilities. The results of their investigations are contained in research documents and reports, which

are available from their headquarters office located in Hanover, New Hampshire.

e. Reservoir Evaporation. The hydrologic methods used in river system analysis for managing water control systems usually entail the logical accounting of the water balance from both natural and man caused effects. Reservoir evaporation may result in significant water losses to the river system. These losses are in addition to those which occur by natural evapotranspiration from the drainage area contributing to runoff. The streamflow data used for operational studies are usually adjusted to account for water loss by reservoir evaporation. There are numerous procedures being used for making such adjustments. The degree of refinement in developing these procedures depends upon: (a) the relative importance of reservoir evaporation in the overall water balance of the region and its effect on the management of the system; (b) the types of basic data available to make estimates to be applied to current and historical data ; and (c) practical considerations concerning the accuracy of the estimates to be attained, as compared with the effort required to obtain the basic data and apply it in a computational method.

f. Determination of Effect of Bank Storage on Reservoir Capacity. Reservoir area-storage-capacity curves used in operational hydrology are normally determined by the use of topographic maps of the reservoir area or special field surveys. The reservoir level pool area is determined incrementally for each of a range of elevations that will represent the variations of area and storage within the operating range of the reservoir. These determinations, however, do not normally take into account any possible effects of storage of water within the aquifers underlying the reservoirs. There may be evidence of significant bank storage in some reservoirs, based on the geology of the area and water balance computations. It is believed, however, that in most cases bank storage is not of sufficient magnitude relative to the computed inflow and outflow to warrant its consideration in water control management.

g. Effect of Wind Setup on Water Levels in Reservoirs, Lakes, and Tidal Estuaries

(1) Water levels observed and reported for reservoirs, lakes, and tidal estuaries may reflect the effects of wind or storm tides, superimposed on the hydraulic effects of flow and tides that occur without wind effects. Particularly in lakes and large reservoirs, the normally assumed "flat pool" or "static pool" as used for computation of daily or period inflows from observed outflows and change in storage may be invalid. Inflows computed in this manner may show apparent fluctuations that are not real and reflect the

effects of daily variations in wind on the lake or reservoir. Corrections must be made to properly account for the effects of wind in this type of computation. A practical expedient for doing this is to maintain a continuous graphical plotting of inflows computed from change in storage computations for the reservoir, along with a plotting of key index inflow gaging stations whose streamflows contribute to the reservoir inflow. The total computed inflow is "smoothed" by eye, as judged by the inflow gaging station plots, to best represent the actual variations of project inflows. When the operation of spillway gates or other outlet facilities are determined, the project releases should be based on best estimates of inflow as adjusted for the effects of wind discussed above, or on inflows computed directly from fixed relationships between total project inflow and observed inflows at key upstream gaging stations.

(2) Prediction of the effect of storm tides and hurricanes on water levels in estuaries is of great importance to water management activities in coastal regions. A third factor is the effect of tsunami ocean waves generated by earthquakes that may occur in coastal areas or in the ocean hundreds or even thousands of miles away. Flood protection works that are constructed for protection of coastal rivers and estuaries are designed for the effects of storm tides, hurricanes, or tsunami waves as applicable. When these projects become operational, the occurrence of storms that would affect the areas should be monitored, and, if necessary, special precautions should be taken to insure their proper operation or to institute flood fights. The methods of monitoring and predicting floods under these conditions should be developed on the basis of requirements for particular areas.



Figure 6-1. Table Rock Dam, White River, Missouri;  
Little Rock District



## CHAPTER 7

### REAL-TIME MANAGEMENT OF WATER CONTROL PROJECTS

#### 7-1. Basic Considerations

##### a. Integration of Generalized Operating Criteria, Real-Time System Analysis, and Project Scheduling

(1) The discussions contained in Chapter 3 deal with the methods used in developing project regulation schedules and operating criteria for project or system regulation as documented in the water control manual. These criteria represent the commitment to an assured plan of regulation based on project justification and all constraints to meet water management goals.

(2) During daily water control management activities, special situations or unanticipated conditions may arise. This requires that a certain degree of flexibility be maintained to depart from normal operating criteria, if necessary. However, any decision to depart from specified criteria must be approved by the Division Commander and be based on a thorough knowledge of current conditions and management goals as specified in ER 1110-2-240. Unusual occurrences such as the spill of pollutants into the waterways may require immediate action that may depart from normal project operation. For example, toxic spills into projects with water supply require immediate response on the part of water managers, including prediction of dilution rates, and time of travel. Such an event will require extensive, complicated coordination and quick development of alternative operating strategies. Similarly, there may be unanticipated changed requirements that involve the safety or use of navigation facilities and waterways, such as ship groundings, shoaling of waterways or docking facilities, or special water requirements for managing terminal or ship repair facilities; the rescue of persons in the waterway whose lives are threatened; or other circumstances which require immediate action for the safety and well being of the general public. In addition to the problems related to normal functional use of the projects, a water management office is often requested to perform a variety of miscellaneous regulations for special purposes, such as maintaining water levels on a short-term basis for construction activities in the downstream waterway, maintaining flows for rafting, white water canoeing or river drifting, or regulating reservoir levels for improvement of wildlife habitat.

(3) All of the above conditions require judgmental decisions by the water control manager to adapt the operating guides to real-time

management. The water control manager relies on information provided by the water control data system, for making decisions that are necessary for daily scheduling. The majority of these decisions do not have far-reaching effects on project regulation, and the decisions are approved as part of normal water management activities. However, some decisions may represent a significant departure from the water control plan or may create adverse impacts on future project regulation activities. If such is the case, recommendations for a particular operation will be referred to higher echelons for written approval as part of the decision making process.

b. Input from Others. The management of nearly all river systems now involves multiagency or multipurpose input. Even though some Corps of Engineers reservoirs may have been constructed initially as single purpose, single agency projects, the changed conditions that reflect the recently added environmental and social impacts of projects have brought a variety of federal, state, and local entities into the water management process. While these agencies or entities do not have responsibility for control and management of Corps of Engineers projects, they do provide significant input, which reflect their technical evaluations and desired regulation goals. Input from these agencies also include current basic data that pertain to project operation and are necessary for system-wide evaluations. These agencies include:

- federal and state environmental control and fishery management agencies
- international, federal and state water resource development or regulatory agencies whose projects or jurisdictions affect the operation of Corps of Engineers projects
- international, federal, regional or state energy authorities, administrations, councils, or commissions
- private utilities or local water boards whose projects or jurisdiction may have impacts on the regulation of Corps projects

Other types of inputs also include current hydrologic data made available from other federal or state water data gathering agencies. These include:

- streamflow, water quality, or water level data from the U.S. Geological Survey or other agency
- current weather data, and weather forecasts and certain hydrometeorological data from the National Weather Service

- snow water equivalent data and related hydrometeorological data from the U.S. Soil Conservation Service
- state or local water agency hydrometeorological and water use data covering state or local water projects

Data from any or all of the above listed agencies or entities may be necessary as input to Corps water regulation activities and would be used or considered in scheduling project regulation. Chapter 8 discusses the methods for coordinating interagency water management activities in greater detail.

7-2. Appraisal of Current Project Regulation. Monitoring system regulation and scheduling future project regulation go hand-in-hand. The objective of monitoring project regulation is to verify that the current operation is proceeding according to the daily regulation schedules and in conformance with the regulation plan as defined by the guide curves and other regulation criteria. Each day the water control manager must appraise the current regulation by comparing actual and guide curve reservoir levels, together with the system demands for each of the functional uses. These comparisons provide the basis for analyzing regulation schedules to meet the future requirements of system regulation in concert with the operating guide curves. The guidelines for scheduling project regulation may be based on the conditions of streamflows and water levels either at downstream control points or at the project, as necessary to meet system demands. For a system of reservoirs operated together, the relative use of storage space for functional needs is defined by the operating guide curves. These guide curves must be analyzed on a daily basis together with the hydrologic and reservoir system conditions to meet the overall objectives.

7-3. Performing System Analyses for Project Scheduling

a. Analytical Requirements for Scheduling Water Regulation at Projects. The daily appraisal of current project regulation provides the water control manager with a general understanding of the hydrologic and project conditions that will affect the scheduling of water regulation in the immediate future. After evaluating current conditions, the water control manager may next consider the input from others which affect project schedules; e.g., immediate needs for hydropower generation, water supply, or other multipurpose functional requirements. The water control manager will also obtain a general review of the current meteorological conditions and the latest forecasts of weather elements that will affect project regulation.

Some of the information thus obtained is quantitative in nature, but not all is susceptible to quantitative definition. To some degree, it would be possible on the basis of subjective evaluations to schedule project regulation without rigorous analysis of the operating conditions. Usually, however, the complexity of the systems and the many variables that must be considered quantitatively preclude the use of simplified procedures or subjective estimates for scheduling the regulation of major water control systems. Computerized analytical procedures that are now available make it feasible to perform analyses of the reservoir and water control systems on a daily basis. These procedures are objective and can account for the effects of each of the major hydrologic and project regulation elements in order to analyze the system response to various alternative project schedules or hydrologic conditions.

b. Preparing Model Input Data

(1) A generalized hydrologic and reservoir regulation simulation model requires various input data:

(a) nonvariable data, which describe physical features such as drainage areas, watershed runoff characteristics for each component watershed, channel routing characteristics, reservoir storage and flow characteristics, and other physical parameters which define the system;

(b) initial conditions data for specifying current conditions of all watershed indexes, incremental flow routing values for watersheds and channels, and current reservoir lake elevations and outflows;

(c) time-variable data expressed as a time-series for representing hydrometeorological inputs and forecasts such as precipitation, air temperature, snowmelt and evapotranspiration functions, streamflow data, project regulation data, or other time-variable elements that affect runoff, project regulation and system requirements;

(2) The project regulation criteria for each run must also be specified, which will conform to the general project regulation criteria contained in the water control plan. Special requirements for water regulation (for example, needs expressed through inputs from other entities) may be included in the specifications to test the feasibility of meeting those needs in conjunction with the water control plan. The water control manager prepares the specific regulation criteria for each run from knowledge of conditions as they exist and the normal or special regulation requirements.

c. Analysis of Results

(1) As stated earlier, the main purpose of real-time system analysis studies is to provide the water control manager with the ability to simulate the proposed regulation and thereby anticipate the effects of operating decisions on future regulation. The simulations are based on the most complete knowledge of present and future conditions in order to analyze the effects on a short- and medium-range time frame, to test the effects of various alternatives of regulation and expected weather conditions, and thereby to provide an objective and rational basis for making operating decisions and scheduling project regulation. Thus, the water control manager is in constant touch with the actual current regulation and the projections of the regulation into the future. The computer system analysis techniques that are designed for this purpose can be operated interactively so that computed results are available in a very short period.

(2) This concept of real-time system analysis provides the opportunity to make repetitive trials of system regulation when conditions warrant it. By performing these analyses routinely, the water control managers become completely familiar with the use of these techniques, so that when emergency conditions arise, they are able to make full use of these capabilities in a timely and efficient manner.

7-4. Water Control Decisions and Project Scheduling

a. Need for Judgmental Determinations in Project Scheduling

(1) Even with the numerical analysis described in the preceding section, the final decisions in formulating project schedules may require the tempering of derived analytical values by the judgment and experience of the water control manager. The water control plans provide the general guidance for project regulation, but they cannot describe the myriad of details that must be accounted for in daily regulation and project scheduling. Further, while the analytical procedures described in the previous section are an attempt to simulate the actual operation within the degree of the ability of the models to represent all processes, the results reflect uncertainties that may be evaluated subjectively.

(2) On a broader scale, judgments may be required to "shade" the operation when conditions indicate a particular need, as, for example, a mid-month adjustment in operating guide curves, which are specifically defined as month end values, and current analysis and projections indicate a probable change in conditions by month end.

The simulation of streamflows and project conditions provides for maintaining the continuity of the hydrologic processes and for providing an outlook of future conditions. These evaluations may form the basis for mid-month adjustments of guide curve operation. By being alert to changed runoff potentials as they occur, the overall efficiency of multipurpose project regulation may be significantly improved. It should be emphasized that modifications of the guide curve operation must be based on rational evaluation of runoff conditions that warrant such departures. When such modifications are made, the water control manager must be constantly alert to changed conditions that would require return to normal guide curve operation.

b. Coordinating Water Control Decisions with Others. Corps offices have the responsibility for managing projects under their jurisdiction. This responsibility is delegated to the working level through the water management functional elements within the operating office. The management of nearly all river systems now involves multiagency or multipurpose input. This input, which is usually obtained through direct communication between the requesting agency and the scheduling office, must be considered in formulating the project schedules. Some of the input is coordinated as provided for in various types of water control management agreements and plans, including:

- interagency water control management agreements with power marketing authorities, fish and wildlife agencies, etc.
- electrical utility coordinated power operating plans and contractual agreements
- water control plans for non-Corps projects which involve flood control or navigation requirements
- water control plans for water regulation projects developed under international treaties
- water compacts with state, regional, or local agencies or councils

There are other types of input from agencies or entities outside of the Corps of Engineers that is not based on formal operating procedures, but through voluntary informal arrangements. The many types of inputs covered by these operating arrangements and agreements has widely varying significance to scheduling the use of water on a daily basis, but all must be coordinated in a manner to meet the water management goals. Routine requests as called for in the agreed-upon operating plans are normally handled by the water

control manager, and minor adjustments may be made to achieve optimum system regulation. If, however, a scheduling problem is encountered involving a question of policy that would significantly affect the planned use of the reservoir storage, the question will be referred to the water control manager for recommendations and action. The final decision will require approval by the Division Engineer.

c. Project Schedules and Operating Instructions

(1) The monitoring, coordinating, scheduling and evaluation of project regulation are normally performed on a daily basis, and the schedules usually represent an operating commitment for the ensuing 24-hour period. Although the projections of project regulation may provide longer-range outlooks, these outlooks are normally subject to change on a daily basis. The schedules and operating instructions may be in various forms, including one or more of the following provisions:

- mean total project discharge in cubic feet per second, for a specified 24-hour period, or for specified amounts for individual period or hourly values (Under some operating agreements, the schedules are required to be made for weekly rather than daily periods if conditions allow.)
- specific gate opening
- target reservoir level as an end of daily or period value
- mean reservoir storage change of acre-feet per day or day-cfs
- specific operating constraints for the ensuing day, as, for example, maximum and/or minimum reservoir levels, maximum and/or minimum project discharges, rates of change of tailwater levels, etc.
- power plant generation as scheduled daily or hourly amounts
- special operating instructions not covered by the specified normal limits of project operation
- special operating instructions for multilevel intake structures

(2) It is required that all project regulation be accomplished within the operating constraints as specified in the project water control manuals. The constraints apply to conditions both at the project and at downstream locations, and they may vary seasonally or may apply to specific requirements that depend upon the conditions of

tributary flow, fishing, or other downstream water use functions. The water control manager is responsible for seeing that the water regulation is performed within all operating constraints and that the daily project schedules and operating instructions are properly carried out.

(3) In times of flood or other types of emergencies, the project schedules must be revised as required to meet the flood regulation goals. This may require 24-hour staffing during flood emergencies when considerable effort is needed to keep abreast of conditions and to adjust the project schedules to reflect changed conditions. These problems are discussed further in Section 7-6.

(4) In times of drought, contingency plans will be needed to assure that all flow requirements are met and reduction in releases are made as appropriate. There may be special local water supply requirements during drought situations that are not part of normal water control management activities. Drought contingency plans are discussed in Section 7-7.

d. Water Quality Aspects of Water Control Decisions. The water quality aspects of project regulation requires a constant awareness of the fact that every regulation decision has an impact on the water quality of the lake and the area of influence downstream. To evaluate the impact of any operating decision requires input from as broad a range of relevant disciplines as possible. With this input the water control manager can make the best choice and derive the most benefit from the project and the resources he controls.

#### 7-5. Disseminating Regulation Schedules

a. Corps of Engineers Projects. Daily schedules and operating instructions must be transmitted from the water management office (Reservoir/Water Control Center, Reservoir Regulation Section, etc.) to each project office in a timely manner. The communication to Corps of Engineers projects may be by telephone, teletype, or other electronic means. For large reservoir systems, where project operation is integrated, it is desirable for each project to receive the schedules for all other projects in that river system. The information allows the project operators to be aware of scheduled operations for upstream projects that may affect their project operation. It also provides the project operators with a more complete understanding of the total system regulation. The projects may also receive the forecasts and outlooks of future project regulation that are obtained from current system studies as described in Section 7-3.



b. Non-Corps Projects. Disseminating flood control and navigation water regulation schedules to non-Corps projects is usually accomplished through the operating office of the project owner. In some cases, however, the operating instructions are transmitted directly to the project, in accordance with operating agreements with the agency or utility. Although the general criteria for scheduling the regulation of non-Corps projects is in accordance with the procedures described herein for Corps projects, the means of scheduling the regulation varies among projects and operating entities. For some projects, all aspects of scheduling are performed by the operating office of the project owner, and the Corps water management office monitors the operation to insure that the project is operated in accordance with agreed-upon project regulation criteria. For non-Corps projects that are integrated into Corps-wide flood control or navigation systems, operating schedules are prepared and dispatched directly by the Corps office.

c. Distributing Schedules to Other Agencies. There are other agencies or entities, which are not project owners or operators, that have a need to know daily water regulation schedules. These agencies include power marketing authorities, streamflow forecasting entities, and fish and wildlife or environmental protection agencies. The schedules are transmitted to them each day to confirm the specific water regulation for the ensuing 24-hour period. Automated water data systems, as described in Chapter 5, may be used for distributing schedules to these agencies. These schedules may be distributed via computer terminal or teletype or telephone for systems that lack a comprehensive automated water data network.

d. Distributing Schedules to General Public. Normally, the daily regulation schedules are considered to be internal working directives that are distributed to agencies or entities directly involved in the water management or streamflow forecasting activities within the river system. Under some circumstances, the general public needs the information contained in the operating schedules. Recreationists that use the river for fishing, boating, drifting, or other activities; navigation, and agricultural or urban riparian interests, who are affected by the regulation of streamflows and river levels, all may need information contained in the operating schedules.

#### 7-6. Water Management Activities During Flood Events

a. Importance of Water Management Activities. Up to now the discussions of scheduling daily regulation have been directed mainly to routine operating conditions based on a cycle of normal daytime operations of the Reservoir/Water Control Center or other water

management element. The intensity of water management activity increases significantly during times of flooding, which may require that the water management office and affected projects be staffed 24 hours per day, including weekends or holidays. Water control managers must closely monitor rapidly changing hydrologic conditions and be prepared to re-evaluate runoff conditions since they may affect project schedules and river conditions at downstream locations. Under rare circumstances, floods may result from dam breaks, earthquakes, landslides, or volcanic eruptions, which may cause serious and unexpected life threatening flood disasters. While this type of occurrence cannot be forecast in advance, such disasters require immediate action when they do occur. Under the more normal types of floods occurring as the result of rain or snowmelt runoff, there is need for frequent direct communication between the water control management element and project operators as the floods progress to obtain the most recent information of conditions at the project that may relate to project regulation. This direct communication is also needed to keep the projects abreast of the most current assessments of schedules and precautions that may affect current operations. The water management office must respond to requirements for issuing flood reports to higher authority and keep other elements of the office fully informed of operational conditions that may affect other Corps activities (e.g., flood fighting, disaster emergency operations, coordination with federal, state and local authorities, and public relations). Under extremely critical floods, the entire effort of Corps installations within the region may be diverted to the activities associated with the flood. This often includes the major basic functional Division or District office elements of engineering, operations, construction, planning, procurement, personnel, and public affairs, as well as other supporting elements. These activities must be directed and coordinated by top level management, and because of the relatively sudden change of activities during flood events, the office must be prepared to adjust its normal activities to a concerted effort required during emergency conditions.

b. Coordination of Corps Activities

(1) Because of the changed direction of activities involving the various elements of the Corps offices during flood events, there is a need for coordination and centralized direction of flood related activities. One of the important aspects of the required coordination is to provide authoritative and timely information regarding the flood. The various elements of Corps offices must be fully informed of current conditions. Therefore, it becomes extremely important that the water management office, as the focal point of water control management activities, be prepared to provide all of the latest information pertinent to the flood conditions,

including:

- a general summary of current weather and hydrologic conditions, their effects on runoff, and areas of flooding
- forecasts of weather conditions, with particular emphasis on the outlook for flood producing potentials
- forecasts of natural and regulated streamflows at the projects and at key downstream locations
- the current status of water control facilities as related to project and system wide management of water for all project purposes, with special emphasis on the effects of regulation on the control of floods throughout the system
- the expected water levels at all key downstream locations, with special emphasis on those areas protected by levees or other control structures
- the planned use of storage space, interior drainage facilities, by-pass and diversion structures for the duration of the flood
- the planned use of non-Corps projects (including international projects) for current flood regulation and the coordination required to achieve the flood regulation goals
- the coordination of flood regulation in the management of multipurpose water control projects with other interests such as public and private utilities, power marketing authorities, fish and game agencies, and state or local water agencies
- description of any special conditions related to weather and river conditions that might affect water regulation and Corps of Engineers activities being undertaken as the result of the flood

(2) Because of the expanded role of the water management office during floods, the resources of that office are fully devoted to meeting its responsibilities for analyzing the system, scheduling and coordinating project regulation, and maintaining continuity of data systems and displays. The briefing room facilities available for normal river and reservoir briefings provide all of the necessary data and information systems required for informational summaries described in the preceding paragraph. Therefore, it is generally highly desirable that these facilities be utilized in an Emergency Operation Center through which the District or Division office

commander may direct the flood activities.

c. Monitoring and Reanalyzing River and Reservoir Conditions During Floods. The principles and methods of real-time system analysis for normal scheduling operations are also applied during major floods, but with special emphasis on keeping abreast of current hydrologic conditions. Because of the importance of maintaining continuity of the rapidly changing events during floods, the efforts on analysis are intensified. During major floods, monitoring the hydrologic events throughout the river system and assessing the latest weather forecasts that affect meteorological inputs are all important in reanalyzing these conditions. When computer simulations are used for analyzing system runoff and projecting reservoir regulation, the continuity of forecasted and observed conditions are compared frequently (perhaps hourly or on a 3- to 6-hour basis), and judgments are made to determine the need for reanalysis of system operation. Thus, the results are being constantly reanalyzed and updated during floods, in order to schedule project regulation most effectively.

d. Adjusting Reservoir Regulation Schedules. As a result of the monitoring and reanalysis of conditions it may be necessary to adjust project schedules on a frequent basis. The needs are determined from the knowledge and experience of the water control manager.

#### 7-7. Drought Management Plans

a. ER 1110-2-1941, Drought Contingency Plans, requires that a drought management plan be developed and implemented as part of overall water control management responsibilities. All Corps projects having controlled storage must have documented drought management procedures. The Water Control Manual for each project will contain a section on special procedures to be followed during droughts. In addition, basin-wide drought management plans should be incorporated into Master Water Control Manuals.

b. When developing a drought management plan, alternate strategies for project or basin-wide operating criteria should be formulated based on the longevity and severity of potential drought events. The following approach should be taken when formulating strategies for project regulation during droughts.

(1) Select critical low flow sequences from historical flow records for detailed analysis.

(2) Develop priorities of water needs considering the

anticipated impact of the drought on activities and resources of the basin. Consider how priorities may change under worsening conditions.

(3) Make computer drought simulations and evaluate alternative water management operating scenarios based on selected historical low flow sequences and the established water need priorities. When reduction of releases are being contemplated, both lake and downstream users should be considered. Results of drought simulations and evaluations should include reservoir inflow, outflow, area, storage, elevation, and water quality parameters.

(4) Make an assessment of the impacts of alternative operating scenarios on basin resources and activities.

(5) Develop tentative basin strategies based on the impact assessment and coordinate these strategies with appropriate local, State, and Federal agencies and other appropriate interests prior to adoption.

c. A coordination plan should be developed for making decisions and implementing actions to be taken during drought situations. The plan should include a public information program and the establishment of a drought advisory committee comprised of representatives from involved agencies. Interests that may be impacted by drought operations should be documented in the coordination plan.

d. After a drought management plan has been developed based on existing constraints, long-term opportunities to modify projects based on changes in basin development and water supply needs should be assessed. This may be accomplished by a reconnaissance study for evaluating the feasibility of alternative actions if current operating constraints are removed or modified. Examples of potential modifications include changes in project operation guide curves, minimum flow requirements, and storage allocations.

#### 7-8. Coordinating Forecasts of Streamflow and River Levels

##### a. General

(1) The river and reservoir system simulation analyses, described in Section 7-3, are the principal technical evaluations used for management of water control systems and scheduling project operation. For those rivers that are controlled by reservoir storage and managed in accordance with the principles outlined in this manual, the streamflow synthesis and reservoir regulation computer

runs constitute the primary source of data on which to base not only the scheduling and control of project operation, but also the forecasts of river conditions in the system as a whole. These computer runs simulate both natural and man caused effects. Therefore, they express the most recent determinations of hydrologic analysis and project schedules by those persons who have the specific knowledge of the hydrologic conditions. Inasmuch as these persons in the water management offices have direct operational control and management of the river systems in which they operate, their operating decisions have primary influence on water conditions in the system, and the hydrologic and river system forecasts for scheduling reservoir operations become the basis for general streamflow and river level forecasts.

(2) Federal and state agencies other than the Corps of Engineers who are also involved in streamflow and river level forecasts must necessarily base their forecasts on assumed or hypothetical effects of project regulation, as well as forecasted conditions of hydrometeorological variables. Water management and river forecasting agencies should coordinate their activities so that the water management decisions and river forecasting data can be based on common information. The exchange of hydrologic and operational data is the first step in coordinating among the offices. A primary goal is to obtain a coordinated forecast which utilizes the expertise of the agencies involved. The ability to achieve this goal depends upon the particular circumstances within each river basin area.

(3) It is important to emphasize that Corps water control management personnel must recognize and observe the legal responsibility of the National Weather Service (NWS) for issuing weather forecasts and flood warnings to the public as described in ER 1110-2-240. Corps water control managers often need to make additional forecasts of stream flows and river levels to best meet multipurpose project water control objectives. Corps forecasts should not be released to the general public unless done through the NWS. Duplication of effort among forecasting agencies should be avoided and forecasts coordinated and shared to the greatest extent possible.

b. Basin-Wide Forecasting Services

(1) An example of a joint operation for basin-wide forecasting of a river system, in conjunction with requirements for project operation and the preparation of river forecasts for the general public, is the Columbia River Forecasting Service. In 1963, the Cooperative Columbia River Forecasting Unit was established by formal agreement between the Chief of Engineers and the Chief of the Weather

Bureau (now the National Weather Service). Under this agreement, forecasting facilities of the North Pacific Division Office of the Corps of Engineers and the Portland River Forecast Center of the National Weather Service (now the Northwest River Forecast Center) are utilized jointly to develop more reliable and timely forecasts of streamflow at key locations. In 1971 the agreement was rewritten, and the Bonneville Power Administration became a party to the agreement 18/. The coordinated forecasting unit was also renamed and is now titled the Columbia River Forecasting Service (CRFS).

(2) A technical committee, which is composed of representatives of each of the three participating agencies, directs the activities of the CRFS. Each of the agencies supports these activities with equipment, facilities, data handling procedures, computer hardware and software, and manpower as required for system development and operational use. The technical committee meets periodically to discuss methods relating to CRFS objectives. More detailed information pertaining to interagency coordination of water management activities is presented in Chapter 8.

(3) Within the Corps of Engineers there are other ongoing cooperative efforts of varying degrees for developing and implementing basin-wide river forecasts.



Figure 7-1. Garrison Dam, Missouri River,  
North Dakota; Omaha District



## CHAPTER 8

### ADMINISTRATIVE AND COORDINATION REQUIREMENTS FOR WATER CONTROL MANAGEMENT

#### 8-1. Administration of Water Control Management Activities

a. Organization. The overall responsibility for water control management throughout the Corps is assigned to the Water Control/Quality Section, Hydraulics and Hydrology Branch, Engineering Division, Engineering and Construction Directorate, HQUSACE (CEEC-EH-W). CEEC-EH-W establishes major policy and guidance pertaining to Corps-wide water control management activities. ER 1110-2-240 establishes the authority and responsibility for water control activities within the Division offices. There are currently seven Division offices in the Corps that have functional Water Control Centers. These are Missouri River, North Pacific, Ohio River, Southwestern, North Central, Lower Mississippi Valley and New England. In Division offices which do not have functional Water Control Centers the water control management responsibilities are usually carried out by the Hydrology/Hydraulics element located within Engineering Division. Although the basic mission and water control objectives of each Division are similar, major differences exist in the types of water control projects and the degree of centralization of responsibilities in the Division and District offices for real-time water management activities. All of the Water Control Centers closely monitor prevailing hydrometeorological and water control conditions throughout their respective Divisions, and all have staff management responsibility over the Districts, except NED, which is an operational Division office having no districts.

b. Functions. There are hundreds of water control decisions made by the Corps each day throughout the nation during normal hydrometeorological conditions. The number and difficulty of these decisions vastly increases during flood events, and most of them are made at the District level. In some Divisions, real-time water control decisions for major projects are made at the Division level. The principal functions required to conduct real-time water control management, whether carried out at the District or Division level, include the following:

- hydrometeorological data collection and processing
- watershed and project hydrologic and water quality analyses
- inter- and intra-agency data exchange

- water control decision-making
- instructions to project operators
- reporting to higher authority
- monitoring project effectiveness and preserving project integrity

The real-time functions stated above are very generalized. They encompass many tasks, such as information exchange, hydrologic forecasting, application of computer models, briefings and release scheduling. Additional supportive activities such as O&M of instrumentation and communication facilities in the office and in the field are also required. Many other developments preparatory to real-time activities are also required prior to their application, such as the formulation of water control plans and "Standing Instructions to Project Operators," compilation of water control manuals, development and adaptation of numerical models, and the establishment of discharge ratings for streams and structures. A significant amount of non-real-time work in the form of annual and post-flood reports are also required. ER 1110-2-1400 provides additional guidance on Water/Reservoir Control Centers and responsibilities.

c. Staffing. The staffs of the Water Control Centers in the Divisions and Water Management Sections in the Districts are normally made up of civil (hydraulic) engineers, meteorologists, environmental engineers and hydrologic technicians. In addition, hydrologists, agricultural engineers, biologists, chemists, physical-scientists, computer technicians and mathematicians contribute significantly to water management in several offices. The responsibilities are highly diversified, and much of the work lends itself to computerization, from basic data collection to modeling water resource systems for multiple water control objectives. Most District and Division water control management elements have acquired high speed computer systems that are dedicated to water control management and have retained full responsibility for both the hardware and software.

d. Role of Project Operators. Physical operation of water control structures for which the Corps is responsible is provided by: the Operations Division of the Corps, owners of non-Corps Federal projects, or by local interests. Project operators, which include damtenders, power plant superintendents, lock masters, resource managers, and others, are furnished standing instructions for water control by the Water Management Section. Information for inclusion in the instructions is discussed in Paragraph 9-2. The hydraulic and

hydrologic aspects of any operation plan in O&M manuals and similar documents are limited to the "physical operation" of structures, such as the manipulation of gates, placement or removal of stoplogs or operation of pumps. Except for very small water control projects where there is little chance for mishap by incorrect operation, project operators are also furnished oral instruction and general information on a real-time basis by water control managers. Clear and direct lines of communication and authority should be established between the water control manager and the project operator. There should be no delay in the communication of instructions to or the receipt of data from the project operator during working or non-working hours. Communication is made directly with the project operator in order to best achieve water control objectives in a timely manner without confusion and error, and to preserve project integrity.

e. Training. It is of the utmost importance that Corps staff having the responsibility for water control management functions be familiar with current technical procedures and computer programs that are available to assist them in carrying out their responsibilities. Although training in the general disciplines involved in water control management is offered at most colleges and universities, formal training focusing on specific aspects of water control management in the Corps is not generally available through regular programs at these institutions. Training directly related to the kinds of problems and situations involved in water control management is offered by selected short-term courses through the Proponent Sponsored Engineer Corps Training Program (PROSPECT) managed by the Huntsville Division. Examples of courses offered through this program and the facility conducting the training are listed below.

- Real-Time Water Control (Hydrologic Engineering Center - HEC)
- Hydrologic Data Management (HEC)
- Reservoir Systems Analysis (HEC)
- Water Quality Modeling of Rivers and Reservoirs (HEC)
- Hydropower Simulation (HEC)
- Water Supply Hydrology (HEC)
- Sediment Transport in Rivers and Reservoirs (HEC)
- Hydrologic Analysis of Floods (HEC)
- Interior Flooding Hydrology (HEC)

- Sedimentation Analysis (Waterways Experiment Station - WES)
- Hydraulic Design for Engineers and Planners (WES)

Several of these courses are also offered periodically through university extension programs. In addition, workshops on these and other subject areas are conducted periodically by HEC and WES.

## 8-2. Briefing Room Facilities

a. General. Water control briefings are held in the Division Water Control Centers and in some District offices. Briefing facilities range from blackboards in the work area to static displays and overhead computer driven projectors in specially designed briefing rooms. Periodic water control briefings are conducted daily or weekly in some offices and only during floods or emergencies in others.

b. Purpose. A briefing room may be developed as an adjunct of the Reservoir/Water Control Center for the purpose of displaying current data related to water management activities and performing briefings of current and planned river conditions and project regulation. It is planned and designed as a focal point of information related to current river regulation, to be used for exchanging information and informing others on river conditions and water management activities on a regular and systematic basis. The facility includes easily understood charts, diagrams, and other visual aids, which are useful for interpreting the data and understanding of water management problems. The briefings are conducted not only for the exchange of information between the various elements within the water management office, but also for informing other office elements whose activities are related to water control management activities. The briefing room facility is also useful for conducting regular or special meetings for coordinating water management activities, and it may serve as a point for disseminating river information to the general public via the news media. Under emergency conditions as described in Section 7-6, the briefing room may serve as a command center for directing not only the water management functions, but also many other Corps of Engineers activities related to the flood or other emergency conditions.

### c. Design

(1) The briefing room is a specially designed facility to utilize a space for seating usually from 10 to 30 persons, arranged

to easily see the visual displays of information that are manually maintained or electronically projected on display facilities. The briefing room, being designed primarily for use in daily briefings of river and reservoir conditions, requires facilities for both visual and audio interpretations and interchange of ideas among the participants. The room may also be used as a source of current information at times other than for the normal river and reservoir briefings. The visual information display systems are the most important element to be considered in the design of the facility. The emphasis in the design for visual systems is in displaying time-variable data that must be kept current on a daily or hourly basis. (See Chapter 5 for a discussion of graphic displays used in connection with an automated data system.) In addition, the visual display system should incorporate fixed information and data that can be easily recalled and displayed as numerical data, photographic projections of project facilities, and numerous other types of fixed data that may be necessary to explain current operations. The primary considerations for designing the display systems are:

(a) Have easily understood and readable charts or diagrams representing time-variable elements which may be updated currently to display all types of real-time hydrologic, project, and river and reservoir regulation data, as necessary for portraying the entire system regulation. Time plots of current data include data immediately preceding the current event, as well as plots of forecast of future events, as continuous functions.

(b) Include in the time-variable chart displays indicators or plots of reference data, such as project guide curves, minimum and maximum pool levels, established heights or discharges of various flood categories at downstream locations, etc.

(c) Provide for both long-range and short-range historical data (i.e., daily, weekly or yearly), as well as projections of future operations.

(d) Provide for immediate access of data available from the water control data system for display purposes via computer terminals. Consider use of large screen display facilities, cathode ray tube monitors, or other electronic readout devices, including the use of color projection equipment, for easy identification of data. Consider also the use of hard copy paper plots derived from computer terminal printers, as well as x-y plotting devices, for continuous semipermanent displays that are readily available for inspection at all times.

(e) Provide for charts and diagrams depicting current weather conditions, prognostic charts, and weather forecasts, together with

plots of time-variable weather indexes related to generation of streamflow, to show trends in weather elements.

(f) Provide for wall displays, photographic projections, or other types of pictorial representations of data pertinent to river regulation and project operation, such as summary hydrograph data, physical characteristics and descriptions of dam and reservoir projects and outlet facilities, generalized and detailed maps of project areas and river tributary systems, charts or diagrams representing hydroelectric project and power transmission facilities, as well as irrigation, navigation, fish passage, and recreation facilities, detailed maps of levee or local drainage projects, summaries and pictorial representations of channel characteristics and flood conditions, etc. Consider use of back-lighted slide projection equipment and large screen electronic display equipment for this function.

(2) In addition to the visual displays described above, the briefing room should be designed to include the capability of two-way conversations among participants in the briefing room as well as those at other locations. This is important to allow participation by persons from other offices in briefing activities. The briefing room should include the electronic equipment necessary to support voice communication and computer terminal facilities required for normal operation. It should also have all communication equipment necessary in the event of its use as a command post during a flood emergency.

(3) In summary, the briefing room should be a specially designed facility to perform the functions outlined above. The facilities should be designed to aid the lay persons as well as the technical experts in river regulation.

#### d. Utilization

(1) As noted above, the primary use of the briefing room is for conducting river and reservoir briefings on a periodic basis, usually on daily intervals. The briefings are performed by the staff engineers of the Reservoir Control Center and supporting elements, such as the River Forecast Center and/or hydraulic engineers who are specialists in hydrologic engineering, hydropower, water quality, or other fields of water engineering. The briefings may be monitored by District office water management personnel or by personnel from other agencies. These persons may also contribute to the discussions on special information that is within their field of activity. Normally, the briefings are held at a fixed time each day and last for about one-half hour. The frequency of briefings and the attendance by staff members of the water management office and others

depends upon the scope of the water control activities and current river and project conditions.

(2) The river and reservoir briefings are conducted under the supervision of the chief of the Reservoir/Water Control Center or other water management element. The normal schedule of the briefing includes the following items:

- summary of current meteorological conditions and weather forecasts
- summary of unregulated (natural) streamflow forecasts
- summary of system reservoir regulation requirements for flood control, hydroelectric power, irrigation, navigation, fish and wildlife, recreation, or other functional uses
- description of reservoir regulation and individual schedules of project operation in downstream order within the system
- summary of outlook of water management conditions expected in the ensuing weeks or months
- questions and discussions among participants

(3) The briefings, as discussed above, represent a means for informing those not directly involved in the scheduling process with the conditions and rationale of current operations. Specific input obtained from the briefings may, however, guide future operations. Although operating decisions are generally made earlier in the day through the processes described in the preceding sections, the briefings provide a means for critically reviewing current operations to assure that the regulation is in accordance with operating plans and to achieve general coordination of current water control activities.

### 8-3. Administration of Water Management Contracts

a. Data Collection. The collection of most water data used by the Corps is supported by the Corps. The U.S. Geological Survey (USGS), National Weather Service (NWS) and other agencies, through cooperative arrangements, provide services to the Corps to install, operate and maintain the instrumentation for essential water data stations. The Cooperative Stream Gaging Program with USGS (stage and discharge) and the Cooperative Reporting Network with NWS (stream stage and precipitation) were established specifically for assistance to the Corps by these agencies. Arrangements to share the cost at

stations are also made to best meet the needs and constraints of each organization. Arrangements may also be made with the USGS to measure streamflow and/or to process the data, including both collection (measurement and transmission) and handling (processing, archiving and publication). Contractual arrangements for water data collection may be made by the Districts, and the draft agreements are submitted to the Water Control Centers or other water management element for review and approval prior to consummation. Contracting water quality data collection is discussed in Paragraph 8-3c below.

b. Water Supply Contracts. Public and private users of storage space in Corps projects are required to contribute a pro rata share of project construction, water supply withdrawal and O&M costs. The Division formulates and processes the contracts, which state explicitly that the Federal government makes no representation with respect to the quality, availability (yield), or treatment of the water. Withdrawals may be made directly from lakes and from streams below lakes.

c. Water Quality Data Collection. A significant amount of water quality data is obtained by contract for the Corps. The contracts may apply to physical, chemical or biological parameters in water and sediments and may consist of everything from field survey to interpretative reports.

d. Hydropower Contracts. Private utilities or entities desiring to construct and operate a non-Federal hydropower generation facility at a Corps project must obtain a license from the Federal Energy Regulatory Commission (FERC). The Corps, upon receiving a license application from FERC for hydropower construction, recommends the best use of the site power potential that is compatible with the multiple water resource use for the public benefit. The Department of Energy (DOE) markets hydropower generated at Federally owned generating facilities at Corps projects and, as stated previously, operating agreements are normally made in this regard. Private utilities enter into contracts with the regional power administration of DOE for purchase of the hydropower.

#### 8-4. Interagency Coordination and Agreements

a. Types of Coordinating Groups. In view of the need for formally constituted groups and methods for coordinating water management activities, various levels of coordinating bodies have been formed which define the working relationships necessary for coordinating scheduling activities. These include the following types of groups:



(1) International Boards, Entities and Operating Committees. These groups operate in accordance with treaties for development or use of international rivers and waterways. These organizations consist of representatives of the U.S. and the adjacent country sharing the water bodies. They may operate at national, regional, or local levels within their respective countries. As such, they may be supervisory bodies that meet infrequently to oversee the operations in order to assure compliance with treaty provisions, or they may be working organizations that meet frequently and communicate as necessary to schedule project regulation.

(2) National Water Resource Coordinating Groups. These coordinating groups are composed of representatives of those Federal agencies at the national headquarters level. These groups coordinate the hydrologic data observation and acquisition programs, acquisition of weather data and forecasts, satellite and ground based communication systems, radio frequency assignments for hydrologic reporting networks, etc., as required for management of water control systems.

(3) Regional River Basin Interagency Committees, Compacts or Commissions. These groups coordinate water management activities within a major river basin or regional areas of the country. These organizations consist of representatives of Federal and state government agencies concerned with planning and construction of projects, and management of water resources within the region. They may be formed voluntarily, by legislative action, or through river basin compacts. Although these organizations may be concerned primarily with planning and construction functions for river basin development, they may also be involved with the problems of coordinating current water management activities for an existing system. They may have subcommittees which deal with the specific problems of coordinating data and river forecasts, and with the technical problems related to multiagency river regulation objectives in general accordance with agency policies and objectives. These organizations are generally not concerned with day-to-day scheduling, but they do deal with current monthly or seasonal regulation.

(4) Operating Committees for Water Use. These committees are formed to coordinate project operating input, as established under contractual agreements with cooperating agencies or utilities for coordinated operation of water control facilities. These committees consist of representatives of the water users, utilities, or government agencies (including the Corps) who are parties to the contract. These persons are generally at the operating level of their organizations, with technical expertise in the scheduling of water or power to meet the contractual requirements. These committees are in close touch with current operations on a monthly or

weekly basis and provide input to water control managers for specific needs. This input will be coordinated with other project requirements and integrated into project schedules. There may also be a supervisory management committee to periodically oversee the operating committee activities and assure that the contract commitments are being met.

(5) Informal Working Relationships. These relationships may be formed between Corps of Engineers water management offices and operators of water control projects owned by navigation companies, local flood control districts, commercial or industrial organizations, etc., which are affected by river regulation. Although these relationships are not formalized in operating agreements, they are an important source of information and coordination and provide input to water control managers.

b. Types of Water Management Agreements

(1) General. The functions and responsibilities of all the above coordinating groups except informal working relationships are formalized by Congressional legislation, by written agreement, or by both. The agreements are usually in the form of Memoranda of Understanding (MOU) signed by the agency heads at the national, regional, or local levels. These agreements, which cover such activities as hydroelectric power generation, fish and wildlife, or water supply, form the basis for carrying out coordination of water management activities by water control managers. This type of arrangement may also be made for coordinating the flood control and navigation regulation of non-Corps projects that are subject to Section 7 of the 1944 Flood Control Act. Even though much freedom may be given another agency toward meeting a desired water control objective, the agreements are very explicit in stating that the Corps is ultimately responsible for the overall achievement of water control objectives, whether complementary or conflicting. There are many such agreements concerning water control management. All such agreements should be reviewed for approval by the appropriate Water Control Center or water management element prior to consummation, and they normally require signature by the Division Commander. Three examples follow:

(2) Data Exchange. Agreements are made with Federal or state agencies regarding the exchange of hydrologic data to be used in making hydrologic forecasts and project regulation in general. These arrangements may be made at the national, regional, or local level. The need for coordination is usually associated with scheduling project regulation. The requirements for coordination of data gathering and exchange and forecasts and/or forecasting activities must be dealt with specifically in each river basin. Actions taken

to coordinate these activities may range from simple exchange of data between agencies to a coordinated data and forecasting center participated in jointly by agency staffs.

(3) Hydrologic Forecasting. The NWS is responsible for the forecasting of hydrological and meteorological events, and for disseminating this information to the public. As part of its responsibility for water control management, the Corps will often supplement NWS forecasts with its internally determined project inflow and local flow forecasts. Corps forecasts should be coordinated with the NWS and project releases provided to that agency.

(4) Hydropower Generation

(a) An agreement concerning hydropower generation at a Corps project or system may be consummated between a Division Commander and the Administrator of a regional Power Administration Office of the Department of Energy (DOE). Such an agreement is supplementary to a water control plan and manual and may be explicit regarding some aspects of coordination and very general in regard to others. Reasons for DOE to seek such an agreement are to clarify its role in the use of Corps projects and to state its objective of maximizing hydropower generation. Reasons for the Corps to enter into such an agreement are to clarify the Corps overall responsibility for water control management, minimize adverse impacts on flood control activities, prevent significant conflict with other water control objectives and preserve project integrity.

(b) In the interest of multipurpose water management, the Corps requires a signed Memorandum of Understanding with the licensee for non-Federal hydropower construction at a Corps project which specifies the operational procedures and power guide curve (water control diagram) to be used and that is consistent with overall project management objectives and efficient system regulation.

c. Coordinating with Operating Entities and Other Public and Private Water Use Organizations

(1) General Considerations

(a) The Corps seldom works alone in the field of water control management. The job of regulating a major river system involves many other organizations which have an interest in the current daily and seasonal water regulation from an operational or forecasting point of view. The coordination of activities stems from many years of effort in working with others in the planning, design, and construction phases of project development. In the operational phase,

particularly with recently enacted public laws and regulations governing the environmental and public use functions of water management, there is an increasing need to coordinate all phases of project regulation with various interest groups. Water control plans, particularly regulation schedules and annual operating plans, are usually developed in concert with other agencies to express contractual arrangements, formal operating agreements or informal accords, in order to assure the various multipurpose water use functions are achieved for mutual satisfaction. These basic efforts for coordination extend beyond the planning and design stages into current operations, usually through interagency coordinating groups, operating committees, or working relationships established with individual agencies. Mostly, these arrangements are voluntary, although many proceed out of legal commitments made in the planning and design phases of project development. The water management activities may require coordination on an international, national, regional, or local basis, involving countries adjacent to the borders of the United States, as well as U.S. Federal agencies, regional or state water or energy authorities, public or private utilities, or local water oriented agencies or public interest groups.

(b) Some elements of water management coordination are a major determining factor in scheduling project regulation. Examples are coordinated system regulation as required under operating agreements for hydroelectric power, water use agreements and commitments set forth in international treaties, and flood control and navigation requirements established for projects subject to Section 7 of the 1944 Flood Control Act. These firm commitments must be fully recognized during project operations, and they require coordinated efforts among the operating agencies to determine the project schedules. This requires exchange of operating data and communication, as necessary, for scheduling project regulation in a manner to assure compliance with the water control plan. Where several operating agencies are involved, the coordination may be achieved under the authority of an operating committee whose membership includes representatives of each of the cooperating entities or, for a single operating agency, by direct communication with that agency.

(c) Other elements of water management coordination involve agencies that do not own or operate projects, but represent water interests which have inputs for project regulation. These may include Federal, state, or local entities involved in environmental protection, fish and wildlife, navigation, irrigation, water supply, recreation, or local boards concerned with land use in the operation of diversion and by-pass facilities. The needs for coordination with these individual entities are usually met by periodic contacts with the Water Control Center or other water management office of the

30 Nov 87

Corps. Finally, there is need for coordinating streamflow and river level forecasts. The particular requirements and methods for coordinating water management activities with other agencies vary widely from region to region within the United States. The needs and desires for achieving coordination depend on the local conditions, and, accordingly, there is no set procedure for doing so.

(d) Regional or river basin water management coordinating groups may be used to institutionalize coordination of current water management activities. As noted previously, coordination may be achieved through voluntarily formed committees or groups or by an operating committee formed as an adjunct of formal operating agreements to implement the regulation plans involving two or more agencies.

(e) The motivation for entering into operating committees or groups depends on the needs and desires of the operating office. Obviously, there is little need to consider the coordination of water regulation activities in situations where the water resource projects are mostly single purpose and where there is little input from others which would affect project schedules. On the other hand, it is more likely that project regulation does interact with other uses of the river system, and the multipurpose requirements cannot be determined unilaterally. In any case, the water control manager should be responsive to all types of river users, and have an "open door" policy to local interest groups, as well as to other operating agencies, in order to consider special requirements or to explain operating procedures. If the needs of this type are infrequent, the interactions can be dealt with informally on a case-by-case basis. If, however, there is a continuing need for exchange of data or consideration of special operating requirements, it is highly desirable to establish formal working relationships to coordinate these activities.

(f) In some respects, the needs and desires for interagency coordination go hand in hand. The desires for this type of activity in any particular area may reflect long standing working relationships between the organizations, which over a period of time, lead to confidence and respect of individuals and organizations in attaining the water management goals through cooperative effort. There is no way to prescribe the methods to be used to achieve these relationships, nor is it possible to direct the degree of effort to be expended. Inasmuch as many of the procedures are based on voluntary actions between the agencies, the decisions on these matters must be based on the initiative and judgment of all parties to best reflect the public interests.

(2) Conflicts in Water Use. In the process of formulating

operating strategies for current water management, conflicts may arise reflecting competing interests of water users. The conflicts may be in connection with interpretation of operating rules and agreements for carrying out the authorized project functions by project user groups (e.g., navigation, power, irrigation or flood control interests), or they may be related to achieving the environmental or social goals in conjunction with the economic and authorized regulation requirements. These conflicts may encompass local or regional problems that have major impacts on various and diverse segments of society with regard to their social and economic well being and their perception of importance to the public good. Although many of these types of problems are dealt with and resolved in the planning and design phases of project development, often other problems of water utilization arise in the operational phase. Furthermore, there may be changes in public attitudes with regard to water management procedures that must be taken into account in scheduling project regulation. The conflicts may involve a wide range of impacts, varying from minor effects in formulating regulation schedules to accommodate a limited water use requirement, to major effects on regional power supplies and employment, fishery resources, flood regulation, environmental impacts, or other impacts related to water use.

(3) Efforts to Resolve Conflicts Through Coordination. Efforts to resolve conflicts in water management are initiated at the working level through the concepts of coordinated operation described in the preceding sections. There first needs to be a thorough exchange of data and information pertaining to the current operation and an explanation of the scheduling requirements between the operating office and the individual water user groups who have an interest in the functional use of the project. These discussions often clarify operating requirements and interpretations of project regulation schedules and serve as a basis for better understanding of the overall requirements for multipurpose regulation. From these discussions, it is often possible to resolve relatively minor conflicts by negotiation and judgmental decisions to adjust project schedules and accommodate special requirements without significantly jeopardizing other water use functions.

(4) Public Hearings on Water Management Problems. It is often desirable to air changes in water control plans and conflicts arising from current water management activities and proposed strategies for regulating projects by holding public hearings. Such hearings may be initiated by the District or Division Commander, in accordance with procedures normally available for this purpose. Such meetings would be publicized with an advanced public notice through the news media, and special invitations would be sent to known interested agencies and local interest groups to present testimony. The purposes of the

meetings are to inform the local interest groups and the general public about problems related to the water management and river regulation activities in the project area, to exchange views on the impacts of alternative methods of regulation, and to seek input which could be considered in formulating operating decisions. The need for public meetings depends upon the severity of the conflicts and the effects of the operating decisions on the general public, with particular emphasis on public use functions, such as fishing, boating, recreation, and aesthetics, combined with the effects on the local economy, employment, safety, and general well being of the people.

(5) Involvement with Elected Public Officials. It is important to keep elected public officials, particularly Congressional representatives and governors, informed in cases where water management decisions have a significant effect on their constituencies. Informal contacts by the District or Division Commanders can alert these public officials to potential problems which may have political significance. Where issues are involved which represent major conflicts and would severely impact a large segment of the public, it may be desirable to suggest that the public officials conduct the public hearings as discussed in the preceding paragraph. In any case, it must be fully recognized by all echelons of command in each Corps office having water management responsibilities that the Corps must be responsive to the needs and desires of the general public in carrying out these responsibilities. The interactions can best be achieved through the elected officials and the general public by anticipating problems, informing and explaining technical objectives and methods of control, listening to input from others, and conducting the operations in a reasonable and prudent manner considering all water management goals.

#### 8-5. Water Management Reports on Prevailing Conditions.

a. General. Much of the project and water data collected in real-time are stored in a data system. The data are used to regulate projects and to prepare reports. The following reports are prepared in concise form to conduct real-time water management from data in data base systems.

b. Project Operators Reports. In addition to reporting water control actions, water data are often monitored by project operators, as specified in the Standing Instructions to the Project Operator for Water Control (see Section 9-2), and furnished directly to the Water Management Section in the District or to the Water Control Center or other water management element in the Division, as appropriate. The requirements for monitoring and reporting are usually more intensive

during flood events.

c. Water Control Morning Reports. These management type reports are used to evaluate watershed and project conditions. They are the principal means of informing all in-house staff having a need to know prevailing conditions, and they take on many forms. The reports are formulated from several small reports on project and hydrometeorological conditions that have been entered into a data base management system each workday morning in a water management office. The information in the reports includes observed water data, hydrologic forecasts, release schedules, and power generation schedules.

d. Special Advisories. Advisories on potential and actual emergency events of any nature that have a significant impact on water management associated with Corps projects (and responsibilities) are reported immediately to the Division water control management element and to CEEC-EH-W by telephone. The advisories provide additional information through water management channels on the water control aspects, when appropriate, of any situation reports that are submitted to higher authority in accordance with Chapter 7 of ER 500-1-1, "Natural Disaster Procedures," 21 December 1984. Some examples are:

- severe weather warnings
- high runoff potential
- flash floods
- emergency conditions affecting the quality of streamflow, water quality and ecology
- any unsafe condition connected with water control that could impact the regimen of streamflow, considering both Corps and non-Corps projects

These advisories are required to keep the Division Commander and Commander, USACE, apprised of events such as the above and, whenever possible, prior to the time they come to the attention of the general public and as they progress. Reports made by telephone are normally followed immediately by a concise narrative summary (Special Advisory) of the event. The follow-up advisories are reported by the most rapid means available for hard copy communication, often by telecopier or computer.

e. Discharge Data. Discharge measurements are made and reported to the water management office in preliminary form as soon



as possible (expeditiously) during flood events for select stations that are vital for real-time decision-making. Adjustment of the preliminary values, when required, are also reported as soon as they are made.

f. Flood Damages. The Districts provide flood damage estimates, potential and actual, to the Division water control management elements for specific areas during prevailing flood events upon special request. Complementary maps depicting areas of inundation and land use may accompany the basic data and may be furnished as computer graphics.

g. Reports for the Media. Water control data at projects and at control points on streams are furnished to the news media. Caution is exercised to avoid furnishing river stage forecast information to the press or organized interest groups since forecasts of river stage are normally disseminated to the public by the National Weather Service (NWS). However, the Districts often furnish forecasts to local interests upon request for areas that are impacted by discharge from Corps projects, after coordinating with NWS. This subject is addressed in ER 1110-2-240.

8-6. Documents, Reports and Records. Several documents and reports on water control management are prepared for use in regulating water resource projects, administrative purposes at the Division and HQUSACE levels, and/or providing a permanent record of project and control point conditions.

a. Water Control Documents. The basic requirement for preparation of water control documents is stated in ER 1110-2-240. The contents of these documents are discussed in Chapter 9. They consist of:

- standing instructions to project operators
- water control plans
- water control manuals (for individual projects and for water resource systems)

b. Annual Operating Plans and Other River Basin Committee Reports. These reports commonly address the achievement of water control objectives during the previous year, and the operating plan for the current or on-coming year for certain project purposes of interagency (joint) interest. Annual operating plans are based on long-term runoff projections. Navigation, hydropower and water supply are the purposes of major concern in these reports. They

long-term runoff projections. Navigation, hydropower and water supply are the purposes of major concern in these reports. They represent the outcome of and plans for mutually agreed to water control decisions.

c. Annual Report on Water Control Management Activities. These reports are prepared by the Districts, consolidated for the Division by water control management elements, and submitted to CEEC-EH-W. They include project accomplishment, progressive development for future plans of the Centers, annual report on water quality activities, and a status of water control documents, with a schedule for their initial preparation and revision. The report is required by ER 1110-2-240.

d. Reports on the Water Control Data System (WCDS) Master Plan. An annual report consists of the original WCDS Master Plan for a Division, with annual supplements for water data collection and handling within each District. The report applies to field instrumentation and to computers used for water data collection. This report, which also includes budget request information, is required by ER 1110-2-240. A quarterly report is also submitted by each Corps District that uses the Geostationary Operational Environmental Satellite Data Collection System on the status of water data transmitters via satellite, which includes all current active transmitters and a deployment schedule for the next four quarters.

e. Annual Report on the Cooperative Stream Gaging Program. This report concerns the funding of water data collection (stage and discharge) provided to the Corps by the U.S. Geological Survey. This activity and the report are discussed in detail in ER 1110-2-1455.

f. Annual Billing for the Cooperative Reporting Network. This transaction consists of a reverse billing procedure between CEEC-EH-W and the Districts to fund water data collection provided to the Corps by the National Weather Service.

g. Annual Budget Request

(1) General. Construction funds are preferably used to prepare the initial preliminary water control documents that are required prior to project completion and to prepare the documents in final form within one year after project completion. Water control managers in the Districts prepare budget requests two years in advance for water control management activities and furnish them to the Operations Division, which manages the O&M, General and MR&T, Maintenance funds, for submission to HQUSACE. The requests are prepared in the March-June timeframe in accordance with annual budget guidance provided by Programs Division, Directorate of Civil Works.

(2) Account 609, Water Control Management. Account 609 is reserved for water control management activities and consists of the following three categories:

- Category E10 (09.1), Data Collection and Maintenance for Water Control and Water Quality Activities,
- Category E11 (09.2), Water Control Analyses and Studies, and
- Category E12 (09.3), Water Quality Analyses and Studies.

Item E10 consists of the cost for single or multiple project water control/quality data collection activities.

(3) Account 630.1, Purchase of Water Control Data System Equipment. Instructions for budget preparation under this account are explained fully in the annual budget guidance. The work functions category code for this account is identified as E15 in the guidance. Item E15 consists of the cost to replace or purchase new equipment for a single project (a non-PRIP purchase).

h. Summary of Runoff Potential. Seasonal reports on hydrometeorological conditions are required by ER 1110-2-240. These brief reports include the outlook for floods resulting from snow accumulation and for droughts, with supplemental reports as the situation progresses.

i. Post Flood Reports. Water control managers contribute significantly to the preparation of post flood reports (see ER 500-1-1). Project regulation effects, including evaluation of stage reductions at key stations and estimates of damages prevented by projects, are determined and furnished to the Operations Division.

j. Water Data Records. Records of stage, discharge, water quality parameters and other information that define water control events are compiled and stored in various ways, including the use of national archives such as STORET, administered by EPA, WATSTORE, administered by USGS, and the precipitation archive at Asheville, NC, which is administered by NWS.

k. Federal Register. See ER 1110-2-240 and ER 1110-2-241.

(1) Corps Projects. A list of Corps and non-Corps projects authorized by Federal laws and directives is published in Part 222.7, Title 33 of the Code of Federal Regulations (CFR). The list is kept up-to-date by CEEC-EH-W with input from the Division and District offices.

Section 7 of the 1944 Flood Control Act is published in Part 208, Title 33 of the CFR by the Corps. The Corps is responsible for prescribing the regulation of these projects for flood control and/or navigation since Federal funds were used for their construction. Part 208.10 applies to small local protection flood control projects that are turned over to local interests for physical operation and maintenance (O&M) after their completion. The requirements in Part 208.10 address O&M, but they do not address regulation of the projects for water control. When appropriate, "Standing Instructions to the Project Operator for Water Control" are prepared by water control managers and furnished local interest group for these projects. Part 208.11 applies to all other projects subject to Section 7 that are not included under Part 208.10. The Corps prepares water control manuals for projects listed under Part 208.11, including water control plans and standing instructions.

1. Annual Report on Project Benefits. Monetary benefits are determined annually for all project purposes that produce tangible benefits. The Economics Branch in the Planning Division routinely computes the benefits attributable to flood control, navigation, hydropower, water supply and recreation using data contributed by the Engineering and Operations Divisions. The information is then furnished to HQUSACE for preparation of the Annual Report of the Chief of Engineers, Civil Works Activities. When appropriate, benefits are also determined for water quality and fish and wildlife enhancement, streambank and beach erosion control, and restoration of the environment (e.g., terrestrial, wetlands or aquatic plant control). An annual flood damage report, which includes damages prevented and damages incurred in each state, is prepared by CEEC-EH-W with significant input from NWS. The report is submitted to Congress in response to House Committee Report 98-217, Energy and Water Appropriations Act, 1984.

m. Annual Water Quality Report. To insure that adequate information on Corps water quality management activities is available to HQUSACE, Division and District water control management elements and other interested parties, a water quality report is prepared annually by each Division and submitted to CEEC-EH-W. The report summarizes the Division's Water Quality Management Program and highlights specific project information, planned activities and other pertinent information, ideas and concerns. Guidance is contained in ER 1130-2-334, Reporting of Water Quality Management Activities at Corps Civil Works Projects.

n. Periodic Inspections and Reports. Water control managers should participate in periodic inspections and review prepared reports for each project to make sure there are no immediate problems that might adversely impact regulation procedures or project water control management activities.

## CHAPTER 9

### PREPARATION OF WATER CONTROL DOCUMENTS

#### 9-1. Basic Documents

a. Types of Documents. The basic documents for management of water control projects or systems of projects consist of one or more of the following:

- Standing Instructions to Project Operators for Water Control
- Water Control Plans
- Water Control Manuals
- Flood Emergency Plans/Initial Reservoir Filling Plans

b. Types of Projects. All water control projects are defined and categorized in the following paragraphs according to size and complexity in order to select the minimum amount of documentation that is needed for a given project. These projects may include lakes and reservoirs, locks and dams, controlled channels and floodways, gated saltwater and hurricane barriers, backwater projects, or large pumping plants.

(1) Type I. Type I projects are relatively small water resources projects that require closing or opening of water passageways, such as floodwalls and culverts using stop logs, sand bags, etc. Also included are uncontrolled weirs, fuseplugs and pump stations at small, non-hazardous impoundments, and small gated structures. The Engineering Division furnishes water control requirements to the Operations Division for inclusion in the O&M manual. However, the Operations Division is normally responsible after that time for any water data collection, monitoring of project conditions, operations, project integrity, and reporting to higher authority.

(2) Type II. These are relatively small water resources projects and require simple, straightforward water control procedures, such as opening or closing minor floodgates or operating stationary pumping facilities. Operation of the structures depends on hydrometeorological conditions that can be expressed in very simple terms to the project operators, such as reaching a given water level. Many of these structures are unattended and usually require a full-open or full-closure action, as opposed to graduated gate operations. Day-to-day monitoring of project conditions may not be

required.

(3) Type III. Examples of water resources projects categorized as Type III include reregulating structures, locks and dams and completely uncontrolled projects. Timely reporting of project conditions can be vital. A water control plan is needed to assure that all objectives for regulation of a project are satisfactorily met. A water control manual is needed when the project is a part of a multiproject system. Real-time water control management is the responsibility of water control managers in the Engineering Division within the appropriate District and/or Division office.

(4) Type IV. These are major water resources projects that involve complex water control procedures, regardless of frequency of use. Type IV projects may include reservoirs, lakes, major diversion structures, pumping facilities and floodways. Complexities may be due to project size, hydrometeorological impacts, discharge facilities, water control objectives, and constraints on water control. During unusual hydrometeorological conditions, the structures are normally attended and normally require water control decisions on a daily basis by water control managers in the District office. However, they may be controlled remotely by communication command systems. Extensive water data collection, hydrologic forecasting, and coordination are often required.

c. Scope of Documentation. There are several projects where water control complexity may not be sufficient to require extensive documentation of water control procedures. For this reason the scope of documentation has been scaled to match the various types of projects discussed above. Type I projects seldom require any water control documentation because of their simplicity. However, in the event it is needed, the Engineering Division furnishes the water control procedures to the Operations Division for inclusion in the O&M Manual for the project. Because of the necessity to make a clear distinction between water control procedures and physical operation, Type I projects are the only projects where water control documentation is included in O&M Manuals. Water control documentation for Types II, III, and IV projects are discussed in the following paragraphs.

#### 9-2. Standing Instructions to Project Operators for Water Control

a. "Standing Instructions to Project Operators for Water Control" are essential to ensure efficient and safe operation of the project at all times. The instructions apply to damtenders, power plant superintendents, lock masters, resource managers, etc. Any physical operating constraints should be clearly outlined to ensure

that water control features are operated in a safe manner and within design limitations during all phases of project life, including the construction phase. Particular care in this regard is exercised during initial acceptance testing of the regulating features of the project.

b. Exhibit A summarizes the information to be included in "Standing Instructions to Project Operators". These instructions must be kept distinct and separate from O&M manuals and are required for all Type II, III, and IV projects. However, the instructions should be referenced within O&M and natural disaster activity manuals, as appropriate. It is important that the instructions provide the only source of information on the regulation of projects for water control that is included in such documents. Therefore, the hydraulic and hydrologic aspects of any operation plans in O&M manuals and similar documents must be limited to the "physical operation" of structures, such as the manipulation of gates, placement or removal of stoplogs, operation of pumps, etc. Thus, the operation plans will apply to physical operation and not to water control (see Exhibit A).

### 9-3. Water Control Plans

a. General. The water control plan for a project is the principal item among the various documents discussed in this chapter. An "Interim Water Control Plan" is prepared when a project is under construction; a "Preliminary Water Control Plan" is prepared well before the time full-scale operation begins; and a "Final Water Control Plan" is prepared within 1 year after operation begins.

b. Interim Water Control Plan During Construction. To ensure that water resource projects perform safely and effectively during construction or modification, it is essential that the "Interim Water Control Plan" be prepared for Type III and IV projects. This is accomplished prior to the date alteration of the watercourse first occurs, or when the construction site becomes subject to flood damage. Interim water control plans remain in force until the project is formally accepted for full-scale normal operation and therefore are prepared prior to completing the "Preliminary Water Control Plan" for Type III and IV projects. The interim plan includes, but is not limited to, the following:

(1) a description of hydraulic features to be provided to protect the project during each phase of construction, including compliance with ER 1110-2-2901;

(2) a plan for water control management during each phase of

construction with references to the maps and plates and including identification of all water data collection stations, parameters measured, and data transmission modes, and an explanation of the method used and time required to forecast streamflow at the construction site during a flood event;

(3) identification of any special conditions during construction that may cause operational constraints;

(4) a description of the impacts of overtopping cofferdams, diversion dikes or embankments at the project site, of flooding borrow areas, and of high stages and high streamflow velocities in general;

(5) safety precautions and appropriate warning systems for potential hazards to upstream and downstream properties or residents, and plans for minimizing the adverse effects associated with partially completed relocations or incomplete flowage rights;

(6) map(s) showing each construction phase, and plan views and cross-sections of diversion dikes;

(7) plates such as discharge rating, stage duration, and flow frequency curves for natural and modified conditions, and degree of protection provided during each construction phase (discharge, stage and freeboard); and

(8) instructions to protect operators regarding constraints on the physical operation of completed or partially completed water control features of the project for interim regulation in general, and for acceptance testing.

c. Preliminary Water Control Plans. A "Preliminary Water Control Plan," pertinent data, filling schedule for storage projects, and "Preliminary Standing Instructions" are prepared at least 60 days prior to completion of construction. The "Preliminary Water Control Plan" is prepared using the outline in Exhibit B for Type III projects or in ETL 1110-2-251 (Chapter VII) for Type IV projects. The relationship with any neighboring water resource project is explained, and the plans for storage projects always include drawdown requirements. Sufficient tables and graphs are included to enable understanding of the preliminary plan.

d. Final Water Control Plans. A "Preliminary Water Control Plan" is replaced by a "final" plan for Type III projects or by a water control manual in final form for a Type III and IV project, as appropriate, within one year after the project is placed in operation.



9-4. Water Control Manuals

a. Water Control Manuals for Individual Projects

(1) Water control manuals are prepared for Type III and IV projects for two main purposes:

- documentation of the water control plan
- a reference source for higher authority and for new personnel who will become concerned with, or responsible for, regulation of the water control project

(2) A manual is prepared for each Type III and IV project as required within one year after the project is placed in operation. The primary reasons for preparing a separate (individual) manual (or appendix to a master manual) for a water control project are:

- to facilitate the use of specific information such as instructions, plates, tables, diagrams and charts for expeditious assessment of prevailing runoff events
- to aid in the water control decision-making process on a real-time basis

(3) Since the main purpose of a manual is for daily use in water control for essentially all foreseeable conditions affecting a project or system, appreciable effort should be made to prepare a usable manual. Essentially all chapters and exhibits in a water control manual should focus on full understanding of the water control plan. Descriptions of structures and water control conditions that constitute an integral part of a project, such as reregulation, pumpback or diversion facilities, should be included in the same (individual) water control manual. The water control plan for a neighboring project within the same system that is not an integral component of the subject project should be presented in a separate individual manual. The required scope of certain chapters or topics in water control manuals for individual projects may be less extensive for those projects within basins or systems where Master Water Control Manuals are either available or planned for the near future. This would be the case when hydrologic forecasting is a broad areal task that encompasses watersheds for more than one structure or project. In this case, information on forecasting may be limited in the individual project manual, with major emphasis presented in a master manual.

b. Master Water Control Manuals

(1) A Master Water Control Manual may be prepared for a system of water resource projects. Appropriate cross referencing between a master manual and appendixes (individual project manuals or plans, as required) can serve to reduce the scope of information regarding specific subjects in one of the compilations. The following subjects are well suited for detailed discussion in a master manual for a water resource system:

- climate of basin and general hydrometeorology
- hydrometeorologic network and data collection
- hydrologic forecasting
- description of the overall integrated Water Control Plan to accomplish "system" objectives
- management of water control activities

(2) The scope and complexity of the last three items above indicate when a master manual is needed for a water resource system. The extent of the first and second items, either individually or collectively, would not constitute sufficient reason to compile a master manual. All charts, graphs, diagrams and other items pertaining to individual projects are presented in the appendixes to the master manual i.e., in the individual project manuals.

c. Initial Reservoir Filling Plans and Flood Emergency Plans

(1) General. It is necessary to prepare emergency procedures for all Corps-built dams to be used in the event that critical conditions develop during the life of the project that may lead to failure of the dam or result in controlled or uncontrolled releases of water resulting in downstream damage. This concern has been directed at recognizing potential dangers, outlining what actions should be taken, and assuring key individuals are aware of their responsibilities or at least have ready access to a plan of action outlining their roles. While the Corps must be continually on the alert for signs of weakening or undue stress within our dams, there are certain critical periods/conditions during the life of a dam that warrant special attention:

- During construction after diversion.
- During construction after closure.

- During initial filling of the conservation pool and the flood control pool.
- During spillway operation, surcharge operation, and possible overtopping.
- During evacuation of the flood control pool.

(2) Plan of Action. Plans of action, for the most part, required for the above periods/conditions would be parallel and duplicate each other. Also, the basic objective of these plans is essentially the same, namely, to provide a ready reference for both Corps personnel and local authorities to identify early signs of potentially dangerous conditions and the subsequent actions to be taken including notification of key personnel, immediate corrective action, and evacuation of downstream areas, if necessary. Therefore, rather than developing a separate plan for each of the above periods/conditions, a single report should be developed to contain contingency plans that will satisfy requirements for potential critical condition occurrences.

(a) The report will contain or refer to water control plans. Water control plans, as described in Chapter 7 of ETL 1110-2-251, are primarily intended for application after the dam is essentially complete. Potential dangerous conditions could exist during project construction; consequently, ER 1110-2-240 requires that water control and contingency plans be developed for use from the date that water is stored behind a partially completed dam until the project is accepted for normal operations. Plans developed for this report may be incorporated, in part or totally, into respective water control manuals.

(b) The development of evacuation plans is the responsibility of the state or local officials. ER 1130-2-419 further requires that appropriate state and local officials be contacted to suggest that evacuation plans be developed as part of the overall dam safety program. Pertinent project information such as dam failure inundation maps should be provided to assist in plan preparation. Therefore, contingency plans may be submitted without the evacuation plans.

(c) The report should be incorporated into the project's Operation and Maintenance (O&M) Manual as an appendage, or by reference to the O&M manual, etc. Inundation maps, included with the flood emergency plans, are no longer required to be placed in water control manuals. Copies of the report should be provided to local authorities, FEMA, respective CONUS Army Headquarters, and the Governor of affected state(s).

(3) New Corps Reservoir Projects. A design memorandum on initial reservoir filling plans will be developed during early construction stages, in accordance with ETL 1110-2-231, for all new Corps reservoir projects. As a minimum, the report should address the following:

- reservoir regulations during project construction stage(s)
- water control plan
- project surveillance
- cultural site surveillance
- flood emergency plan
- public affairs
- safety plan
- transportation and communications

(4) Existing Corps Reservoir Projects. Existing Corps projects, where the maximum pool (top of flood pool) has not been experienced, should be reviewed for compliance with requirements as outlined in Paragraph (3) above. For those conditions where contingency plans have not been documented and potential danger still exists due to filling and/or impounded storage, a report should be developed outlining those plans. The document may be titled "Flood Emergency Plan" providing that additional initial filling requirements are deemed not to have significant potential impacts on the safety of the structure. However, such a determination does not preclude the "Flood Emergency Plan" from containing or making appropriate references to water control plans, project surveillance, cultural site surveillance, safety plan, transportation and communications, etc. The plans are prepared as described in "Flood Emergency Plans" 19/. A review should be made of those projects that have filled or have been nearly full to determine whether problems were experienced during their initial fillings. If the review surfaces experienced problems and if the problems are likely to reoccur during subsequent fillings, a filling plan should be developed for those potentially hazardous conditions.

#### 9-5. Format of Water Control Documents

a. General. Standing instructions to project operators, water control plans, and water control manuals are prepared using the suggested format and content shown in Exhibits A and B and ETL 1110-2-251, respectively. The chapter titles shown in ETL 1110-2-251 should be considered for all master and individual project water control manuals, even though some of the chapters may require only limited information on the subject. Topic and subtopic titles may be varied slightly to fit the project at hand.

b. Tables, Graphs, and Plates. Tables and graphs less than one-half page in size may be dispersed throughout the text as they are referred to. All remaining tables and graphs are best included with the plates in the back of the document to facilitate narrative continuity within the text, labeling them as plates rather than tables or graphs. Interrelated graphs and tables may be placed on the same plate whenever possible.

c. Use of the Terms "Regulation" and "Operation". When preparing a water control document, the term "regulation" is used to define either: (1) water control plans, procedures, and decisions that are normally determined by water control managers (hydrologic or hydraulic engineers); or (2) legal rules, agreements or contracts, e.g., Section 7 Flood Control or Navigation Regulations, FERC license, Water Supply Contracts, and Rulings of Interstate Compacts. The term "operation" is used in relation to the physical manipulation of spillway gates, outlet works or instrumentation associated with projects, insofar as practicable. Such a distinction in written form between "regulation" and "operation" will facilitate a better understanding of the water control documents.

d. Document Identity. All water control narrative instruction and related material are documented and bound under separate cover from Operation and Maintenance, Emergency Operation, and Natural Disaster Activity Manuals. This separation enables a better understanding of "water control management" and "physical operation" aspects of water resource projects.

#### 9-6. Coordination of Water Control Documents

a. General. The Division Commanders are responsible for approving water control plans and manuals (see ER 1110-2-240).

b. Coordination. Water control documents are prepared by or under the direction of water control managers in the Engineering Division. The documents are coordinated within the District and/or

Division offices and, when appropriate, with local, state and Federal agencies for "review and comment" prior to approval in final form. Water control managers in the District offices also take the initiative to maintain close contact with the Division Water Control Centers or other water control management elements during development and revision of water control documents. A checkpoint meeting may be appropriate after completing either a water control plan or manual in draft form. This applies to initial and revised plans and manuals, both for individual projects and for water resource systems.

c. Water Management Agreements. Any inter-agency water management agreements proposed by a District, such as Memorandums of Understanding, are submitted to the Division Water Control Center or other water control management element for review and approval prior to consummation. Some examples are: Section 7 Flood Control Regulations; Water Supply Contracts; Power License Contracts; Field Working Agreements; Memorandums of Understanding; and letters from other agencies, minutes of River Basin Commissions, Compacts or Coordinating Committees requesting, acknowledging or concurring in certain important or unusual aspects of the plan for water control.

EXHIBIT A

STANDING INSTRUCTIONS TO THE PROJECT OPERATOR<sup>1/</sup>

FOR WATER CONTROL  
(largest bold type)

STRUCTURE OR PROJECT NAME  
(large bold type)

STREAM

River Basin

Exhibit \_\_\_\_\_<sup>2/</sup>

to the

Water Control Plan (or Manual)

for

(Parent Project Name)

District Office

U. S. Army Corps of Engineers

Date

<sup>1/</sup> Required for all Type II, III and IV projects (see Paragraph 9-1b).

<sup>2/</sup> Omit for Type II projects that are not in a water resource system.

Information to be Included in  
STANDING INSTRUCTIONS TO THE PROJECT OPERATOR FOR WATER CONTROL<sup>1/</sup>  
(PROJECT NAME)

Type      Project

PHOTOGRAPHS OF ALL WATER CONTROL STRUCTURES (TYPE II PROJECTS ONLY)

TABLE OF CONTENTS

PERTINENT DATA

1. BACKGROUND AND RESPONSIBILITIES.

a. General Information.

(1) Reference compliance with Paragraph 9-2 of EM 1110-2-3600 and ER 1110-2-240, and state that a copy of these Standing Instructions must be kept on hand at the project site at all times, and that any deviation from the Standing Instructions will require approval of the District Commander.

(2) Identify authorized project purposes and all water control objectives.

(3) Identify chain of command and the entity to which the project operation is responsible for water control actions.

(4) State project location and brief description of water control structures.

(5) Describe constraints on physical operation of the water control structure.

(6) Include a statement as to whether O&M is by the Corps or by local interests, and a statement as to whether it is a local protection project. Reference the Code of Federal Regulations (CFR Title 33, Part 208.10) when it applies.

b. Role of the Project Operator.

(1) Normal Conditions (not dependent on day-to-day instruction). Applies to all Type II and some Type III projects.



Include the following statements..."The Project Operator is responsible for water control actions during normal hydrometeorological conditions (non-flood, non-drought) without daily instruction. However, the water control manager should be contacted any time conditions are such that consultation or additional instruction regarding water control procedures is needed."

OR...Normal Conditions (dependent on day-to-day instruction). Applies to some Type III and most Type IV projects. When appropriate, state that..."The Project Operator will be instructed by water control managers on a daily basis for water control actions under normal conditions".

(2) Emergency Conditions (flood or drought). Same as above, as appropriate, during flood events and other emergency conditions.

## 2. DATA COLLECTION AND REPORTING.

a. Normal Conditions. Instructions for collecting water data under normal hydrometeorological conditions, and instructions for reporting the water data to the District office.

b. Emergency Conditions. Same as the above during flood events and other emergency conditions. Specify more intensive requirements when appropriate.

c. Regional Hydrometeorological Conditions. State that..."The Project Operator will be informed by the water control manager of regional hydrometeorological conditions that may/will impact the structure."

## 3. WATER CONTROL ACTION AND REPORTING.

a. Normal Conditions. Specific step-by-step instructions for water control action under normal hydrometeorological conditions, taking into account any constraints on water control or physical operation, and specific step-by-step instructions for reporting the action and any unusual conditions to the water control manager.

b. Emergency Conditions. Same as the above during flood events and other emergency conditions.

c. Inquiries. State that..."All significant inquiries received by the Project Operator from citizens, constituents or interest groups regarding water control procedures or actions must be referred directly to water control managers."

d. Water Control Problems. State that... "The water control manager must be contacted immediately by the most rapid means available in the event that an operational malfunction, erosion, or other incident occurs that could impact project integrity in general or water control capability in particular."

e. Communication Outage. Specific step-by-step instructions for water control action in the event a communication outage with the water control manager occurs during either normal or emergency conditions, considering constraints.

PLATES (to support the above, use 11-inch binding edge).

a. Map of the project area showing the water control structures, streams, levees, dikes, channels, water data stations and parameters measured, with a vicinity map insert depicting the drainage area above the project.

b. Schematic drawing of the project facilities, including a plan and profile of water control structures which show key water levels (headwater and tailwater), and other pertinent information.

c. Forms for collecting water data, reporting water data, and reporting water control actions.

d. Discharge rating curves, if appropriate, with key elevations identified and a rating table inserted on the graph.

e. Water control diagrams and release schedules, if appropriate, for normal and emergency conditions, and for communication outages.

f. List of points of contact in District and/or Division office.

g. Other supporting plates, if needed.

1/ Required for all Type II, III and IV projects. Include project name and type in heading. Include water management symbol in upper left corner, and date in upper right corner of each page.

EXHIBIT B

WATER CONTROL PLAN<sup>1/</sup>  
(largest bold type)

STRUCTURE OR PROJECT NAME  
(large bold type)

Stream

River Basin

Appendix \_\_\_\_\_

to the

Master Water Control Manual

for

(Parent Project Name)

District Office

U.S. Army Corps of Engineers

Date

<sup>1/</sup> This format is used for Type III projects only (see Paragraph 9-3); i.e., when a water control manual is not prepared. Use the format of Chapter VII in ETL 1110-2-251 for Type III & IV projects; i.e, when a water control manual is prepared.

Minimum Requirements for

WATER CONTROL PLAN

(PROJECT NAME)<sup>1/</sup>  
Type III Project<sup>1/</sup>

PHOTOGRAPH OF ALL WATER CONTROL STRUCTURES

TABLE OF CONTENTS

PERTINENT DATA

- Information in Concise Summary Form -

1. INTRODUCTION. State the requirement for the Water Control Plan (ref ER 1110-2-240, ref Part 208.10 of CFR, Title 33, when applicable, and state as Type III project), project authorization, purpose, location, description, and completion date of the principal and related projects.
2. PROJECT FEATURES. Description of all water passageways (discharge facilities, inflow and outflow channels, etc.), related water resource projects, and all public use facilities.
3. HYDROMETEOROLOGY AND WATER QUALITY<sup>2/</sup>. Watershed description, climate, runoff, table showing average monthly precipitation in inches and average monthly runoff in both inches and cfs, water quality, design conditions, water passageway characteristics, data collection stations and maintenance of instrumentation, data collection procedure and reporting (refer to exhibit on Standing Instructions to the Project Operator), method of preparing hydrologic forecasts if done in-house, and source, access procedure and overall suitability of forecasts if obtained from NWS.

- Detailed Information -

4. WATER CONTROL PLAN<sup>3/</sup>. Overall summary of the water control plan, including objectives and major constraints, followed by: specific objectives, the regulating procedures, and the beneficial effects of regulation for each water control objective. Address the following objectives, as appropriate: flood control (include regulation for design flood), navigation, water supply, water quality, fish and wildlife, hydropower, recreation, and any other water control objectives and incidental achievements. The discussions should include examples of regulation and any constraints.

5. PROJECT MANAGEMENT<sup>2/</sup>. Project owner, role of the regulating office (water control managers, and summarize requirements for the Water Control Morning Report for the subject project); role of the Project Operator (refer to exhibit on Standing Instructions); communication between the District office and project operator; coordination with local, state and other Federal agencies, if required, and future changes to the project and the impact on water control.

PLATES (using 11-inch binding edge, label tables not in text as plates).

- a. Map and plan of project area with vicinity map insert.
- b. Plan and profile of structure clearly showing all discharge facilities.
- c. Data collection network map (designate auto-recording, auto-reporting and key control point(s)).
- d. Water Control Diagram (guide curve), with release schedule and explanatory notes, when applicable.
- e. Discharge rating curves with rating table insert (designate important related elevations).
- f. Hydrograph examples of water control regulation (inflow and outflow), with hyetographs (for floods of record and the design flood).
- g. Frequency and duration curves for headwater or pool and control point or tailwater (discharge and stage).
- h. Other plates as required for the project at hand.

EXHIBITS.

- a. Detailed Pertinent Data.
- b. Other Exhibits, as appropriate.
- c. Memorandum of Understanding or other Agreement.
- d. Standing Instructions to the Project Operator for Water Control (see Exhibit A).

1/ This format applies only to Type III projects where the scope of water management does not require preparation of an individual water control manual. However, the water control plan should be appended to the Master Water Control Manual when the project is in a water resource system. The plans and standing instructions for water control structures in the system may be prepared and submitted for approval prior to the master manual, if desired, to expedite the most essential documentation requirements. Include project name and project type in heading.

2/ Detailed presentation of these topics in the system master manual is preferred when one is prepared.

3/ See Chapter VII of ETL 1110-2-251 for further guidance.

## APPENDIX A

### BIBLIOGRAPHY

#### PREFACE

Much of the subject matter contained in this manual is derived from actual experience gained through the real-time management of Corps of Engineers reservoirs throughout the United States. These practices are, however, based on general guidelines and criteria established by HQUSACE. The principal reference material is contained in the Engineering Regulations, Engineering Manuals, Engineering Technical Letters, and other documents as listed in Chapter 1. These publications, in turn, contain many references which describe technical procedures related to the particular subject of the publications.

Documentation of the experience of actual application of these principles has been limited to technical explanations of those procedures that have been developed and utilized by various Corps of Engineers District and Division Offices, as set forth in technical papers and symposia proceedings. This manual has in part drawn upon these publications and thereby represents an attempt to consolidate both published and unpublished information, based on current practices in water control management by the Corps of Engineers.

The following references are technical publications dealing with technical methods. They are either specifically referenced in the text, or they are general references that pertain to the subject as background material but not specifically referenced in this manual. There is a wealth of reference material on the general subject of developing and utilizing water control systems, but the bulk of this material is concerned with the planning and design of these systems. The portion of the material dealing with real-time management is much smaller. The general references listed here have been selected from those which are directed to real-time management and exclude those which are directed primarily to planning or design of water control projects.

SPECIFIC REFERENCES

1. U.S. Army Corps of Engineers, Hydrologic Engineering Center, "Flood Control by Reservoirs, Hydrologic Engineering Methods for Water Resources Development," International Hydrologic Decade, Volume 7, Davis, California, February 1976.
2. U.S. Army Corps of Engineers, Southwestern Division, "Water Control Data System Software Manual," Dallas, Texas, February 1983.
3. U.S. Army Corps of Engineers, Hydrologic Engineering Center, "Water Control Software, Data Acquisition," Davis, California, November 1985.
4. U.S. Army Corps of Engineers, Hydrologic Engineering Center, "Water Control Software, Implementation and Management," Davis, California, November 1985.
5. U.S. Army Corps of Engineers, Hydrologic Engineering Center, "Water Control Software, Forecast and Operations," Davis, California, December 1985.
6. U.S. Army Corps of Engineers, Hydrologic Engineering Center, "HECDSS, Users Guide and Utility Program Manual," Davis, California, October 1986.
7. U.S. Army Corps of Engineers, North Pacific Division, "Columbia River Operational Hydromet and Management System, CROHMS," Design Memorandum No. 1, Portland, Oregon, April 1974.
8. U.S. Army Corps of Engineers, North Pacific Division, "Columbia River Basin Master Water Control Manual," Portland, Oregon, December 1984.
9. U.S. Army Corps of Engineers, North Pacific Division, "Columbia River Operational Hydromet Management System, CROMS," Users Manual, Portland, Oregon, 1978.
10. U.S. Army Corps of Engineers, North Pacific Division, "Summary Report of the Snow Investigations, Snow Hydrology," Portland, Oregon, June 1956.
11. U.S. Army Corps of Engineers, North Pacific Division, "Hydro-System Seasonal Regulation Model, HYSSR," Users Manual, Portland, Oregon, March 1972.



12. U.S. Army Corps of Engineers, Hydrologic Engineering Center, "Simulation of Flood Control and Conservation Systems (HEC-5)," Users Manual, Davis, California, April 1982.
13. U.S. Army Corps of Engineers, North Pacific Division, "Streamflow Synthesis and Reservoir Regulation, SSARR," Portland, Oregon, September 1972 (revised, June 1975).
14. U.S. Army Corps of Engineers, Hydrologic Engineering Center, "Flood Hydrograph Package (HEC-1)," Users Manual, Davis, California, September 1981.
15. U.S. Army Corps of Engineers, North Pacific Division, "Hydro-Power System Regulation Analysis, HYSYS," Users Manual, Portland, Oregon, May 1971.
16. U.S. Army Corps of Engineers, North Pacific Division, "Hourly Load Distribution and Pondage Analysis Model, HLDPA," Portland, Oregon, April 1981.
17. Linsley, R. K., M. A. Kohler, and J. L. Paulhus, Hydrology for Engineers, Second Edition, McGraw-Hill Co., New York, 1975.
18. U.S. Army Corps of Engineers, North Pacific Division, "Memorandum of Understanding, Columbia River Forecasting Service," U.S. Weather Service, and Bonneville Power Administration, Portland, Oregon, 1971.
19. U.S. Army Corps of Engineers, Hydrologic Engineering Center, "Flood Emergency Plans," Davis, California, June 1980.

#### GENERAL REFERENCES

1. Proceedings of a Seminar on Real-Time Water Control Management, 17-19 November 1975, Hydrologic Engineering Center, Davis, California.
2. Proceedings of the National Workshop on Reservoir Systems Operations, August 13-17, 1979, sponsored by the American Society of Civil Engineers and the Office of Water Research and Technology, U.S. Dept. of the Interior, edited by Dr. Gerrit H. Toebe and Alice A. Shepherd, and published by the American Society of Civil Engineers, New York, New York.
3. Proceedings of a Symposium on Accomplishments and Impacts of Reservoirs, sponsored by the ASCE Water Resources Planning and Management Division, October 20-21, 1983, edited by Gordon G. Green and Earl E. Eiker, published by the American Society of Civil Engineers, New York, New York.
4. Proceedings of a Meeting on Modeling of Snow Cover Runoff at the U.S. Army Cold Regions and Engineering Laboratory, 26-28 September 1978, edited by S. C. Colbeck and M. Ray, sponsored by the American Geophysical Union and American Meteorological Society, and published by the Cold Regions Research and Engineering Laboratory, Hanover, New Hampshire.
5. Proceedings of the International Symposium on Rainfall-Runoff Modeling, May 18-21, 1981, Mississippi State University, Mississippi, edited by Vijay P. Singh, published by Water Resources Publications, P.O. Box 2841, Littleton, Colorado 80161.

NOTE: The above referenced proceedings contain many technical papers prepared by authors who have had experience in some particular aspect of management of water control systems or in the technical aspects of applied hydrology, which may be used in analyses of water control systems.

APPENDIX B

INDEX

Account 609 . . . . .	8-19
Air Vents . . . . .	4-07
Aesthetic Considerations . . . . .	2-03, 2-34, 3-05, 3-19
Algae . . . . .	2-21, 4-06, 6-14
Ammonia . . . . .	2-21
Anadromous Species . . . . .	2-26
Annual Water Quality Report . . . . .	8-20
Aquatic Life . . . . .	2-21, 5-06
Aquatic Macrophytes . . . . .	2-25
Aquatic Plants . . . . .	2-25
Automatic Generation Control . . . . .	4-27, 4-28
Bank Erosion . . . . .	2-31, 2-32
Bank Storage . . . . .	6-16, 6-18
Blending of Flows . . . . .	2-22, 4-09
Briefing Room Facilities . . . . .	7-11, 8-04
Bulkheads . . . . .	2-08, 4-07
Bureau of Reclamation (USBR) . . . . .	2-05, 4-05, 5-08, 5-18
Bypass Structures . . . . .	1-03, 2-09, 2-10, 4-01, 4-23
Cavitation . . . . .	4-02, 4-04, 4-07 - 4-09, 4-12, 4-23
CEEC-EH-W . . . . .	8-01, 8-16, 8-18 - 8-20
Central Receiving Site . . . . .	5-07, 5-10, 5-11
Channel Capacity . . . . .	2-32, 3-12, 3-24
Channel Routing . . . . .	7-04
Chute Spillway . . . . .	4-03
Cold Regions Research and Engineering Laboratories (CRREL)	6-17
Columbia River . . . . .	2-13, 4-35, 5-19, 7-14, 7-15
Columbia River Forecasting Service (CRFS). . . . .	7-14, 7-15
Columbia River Operational Hydromet Management System (CROHMS) . . . . .	5-19
Committee on Water Quality . . . . .	2-22
Computer Systems . . . . .	8-02
Computer Utilization . . . . .	6-02, 6-03
Concrete Overflow Spillways . . . . .	4-03
Constraints on Water Control Plans . . . . .	3-24
Control Valves . . . . .	4-07, 4-08
Cooperative Data Systems . . . . .	5-19
Cooperative Reporting Network . . . . .	5-05, 8-07, 8-18
Cooperative Stream Gaging Program . . . . .	1-06, 8-07, 8-18
Coordinating Groups . . . . .	4-29, 8-08 - 8-10, 8-12, 8-13
Critical Period . . . . .	6-12

Dam Safety . . . . .	9-07
Data Acquisition Controller (DAC) . . . . .	5-10, 5-13, 5-16
Data Collection . . . . .	1-01, 1-04, 1-06, 2-20, 2-21, 3-21, CH 5, 8-01, 8-02, 8-07, 8-08, 8-18, 8-19, 9-01, 9-02, 9-04, 9-06, 9-13, 9-16, 9-17
Data Collection Platform (DCP) . . . . .	5-06, 5-07, 5-11
Data Exchange . . . . .	3-04, 5-19, 8-01, 8-10
Data Interpretation . . . . .	5-15
Data Observation and Storage . . . . .	5-03, 5-06
Data Processing . . . . .	1-02, 1-04, 5-03, 5-15, 5-16, 6-03
Data Transmission . . . . .	1-06, 5-07 - 5-09, 5-13, 5-14, 5-18, 9-04
Degradation . . . . .	2-24, 2-31
Department of Energy (DOE) . . . . .	4-27, 5-18, 8-08, 8-11
Deposition . . . . .	2-31 - 2-33
Design Flood . . . . .	3-11, 3-13, 4-06, 4-14, 4-17, 6-01, 9-16, 9-17
Design Head . . . . .	4-05
Design Water Level . . . . .	6-06
Device for Automatic Remote Data Collection (DARDC) . . . . .	5-13, 5-14
Direct Readout Ground Stations . . . . .	5-11
Dissolved Oxygen . . . . .	2-22, 2-27, 4-36, 5-05, 6-14
Diversions . . . . .	2-09, 2-14, 2-16, 2-17, 4-23, 4-25
Division Commander . . . . .	2-16, 7-01, 8-10, 8-11, 8-14, 8-16
Drawdown . . . . .	2-25, 2-26, 2-33, 2-34, 3-25, 4-07, 4-22, 9-04
Drought Conditions . . . . .	3-05, 6-05
Drought Contingency Plans . . . . .	1-06, 2-19, 7-08, 7-12
Drought Management . . . . .	7-12, 7-13
Drum Gates . . . . .	4-05
Economic Analysis . . . . .	5-19
Emergency Gates . . . . .	4-07
Emergency Operation Center . . . . .	7-11
Emergency Preparedness . . . . .	4-25
Energy Dissipators . . . . .	4-03, 4-04
Engineering Division . . . . .	8-01, 9-01, 9-02, 9-09
Engineering Manuals (EM) . . . . .	1-06, 1-07, 2-14, 2-21, 2-22, 3-17, 3-24, 4-03, 4-05 - 4-07, 4-26, 6-01, 6-06, 6-15, 9-12
Engineering Regulations (ER) . . . . .	1-05, 1-06, 2-01, 2-15, 2-18 - 2-22, 4-07, 5-01, 5-02, 5-14, 5-18, 7-01, 7-12, 8-17, 8-18, 8-19, 8-20, 9-03, 9-07, 9-09, 9-12, 9-16
Erosion . . . . .	2-24, 2-31 - 2-33, 3-25, 4-02, 4-04, 4-08, 4-12, 8-20, 9-14
Estuaries . . . . .	2-10, 2-11, 2-14, 4-23, 4-24, 6-16, 6-18, 6-19
Evaporation . . . . .	1-04, 5-03, 6-16, 6-18
Extratropical Storms . . . . .	6-07
Federal Energy Regulatory Commission (FERC) . . . . .	2-15, 2-16, 8-08, 9-09

Federal Power Act . . . . .	2-15
Federal Register . . . . .	1-03, 1-06, 8-19
Fish and Wildlife Coordination Act . . . . .	2-01, 2-23
Fish and Wildlife Enhancement . . . . .	2-23, 4-23, 8-20
Fish and Wildlife Service . . . . .	2-24
Fish Attraction Water . . . . .	4-34, 4-35
Fish Hatcheries . . . . .	4-36
Fish Migration . . . . .	2-27, 4-04, 4-34 - 4-36, 6-14
Fish Passage Facilities . . . . .	1-03, 3-08, 4-01, 4-33, 4-34
Flood Control Act of 1936 . . . . .	2-04
Flood Control Act of 1944 . . . . .	2-05, 2-16, 2-18, 2-29, 8-10, 8-12, 8-20
Flood Control Benefits . . . . .	2-05, 3-13, 3-14
Flood Control Operation . . . . .	2-19, 4-10
Flood Control Storage . . . . .	2-06, 2-07, 3-11, 3-14, 3-15
Flood Damage . . . . .	2-05, 2-06, 2-09, 8-17, 8-20, 9-03
Flood Emergency Plan . . . . .	9-08
Flood Forecasts . . . . .	2-05
Forecasting Services . . . . .	7-14
Free-Flow . . . . .	4-12 - 4-14
Freeboard . . . . .	2-07, 2-08, 4-05, 4-14, 9-04
Gas Supersaturation . . . . .	4-36, 4-37
Gate Passageways . . . . .	4-07
General Public . . . . .	1-05, 2-01, 2-12, 2-29, 2-30, 3-05, 3-19, 4-24, 7-01, 7-09, 7-14, 8-04, 8-15, 8-16
Generating Capacity . . . . .	4-32
Geological Survey (USGS) . . . . .	5-04, 5-06, 5-18, 7-02, 8-08, 8-07, 8-18, 8-19
Geostationary Operational Environmental Satellites (GOES) . . . . .	1-06, 5-05, 5-10, 5-11, 5-13, 5-14, 5-18
Graphic Displays . . . . .	8-05
Gravity Outlets . . . . .	4-24
Guide Curve . . . . .	3-09, 7-03, 7-06, 8-11, 9-17
Hardware and Software Requirements . . . . .	5-16
HQUSACE . . . . .	2-16, 4-01, 4-06, 5-02, 8-01, 8-17, 8-18, 8-20
Hurricane Barriers . . . . .	4-24, 9-01
Hurricanes . . . . .	1-04, 2-10, 5-13, 6-06, 6-07, 6-19
Hydraulic Cylinders . . . . .	4-07
Hydraulic Design . . . . .	1-07, 4-10, 4-34, 8-04
Hydrogen Sulfide . . . . .	2-21, 3-23
Hydrograph . . . . .	1-07, 4-18, 4-22, 8-06, 9-17
Hydrologic Data . . . . .	3-08, 3-09, 3-22, 4-25, 5-04, 5-08, 5-10, 5-13, 5-14, 5-16, 6-12, 7-02, 8-03, 8-09, 8-10
Hydrologic Engineering Center (HEC). . . . .	4-19, 5-16, 8-03, 8-04
Hydrologic Modeling . . . . .	3-16
Hydropower Plants . . . . .	2-14, 4-26, 4-27, 4-31

Ice Jams . . . . .	2-33, 5-04, 6-17
Impoundments . . . . .	1-06, 2-02, 2-05, 2-06, 2-08, 2-21, 3-03, 3-25, 4-07, 9-01
Induced Surcharge Storage . . . . .	4-11, 4-13, 4-14, 4-17, 4-19, 4-22
Initial Reservoir Filling . . . . .	1-07, 9-01, 9-06, 9-08
Instream Flow Requirements . . . . .	2-03, 3-05
Intake Structure . . . . .	2-33, 4-08, 4-09
Interagency Coordination . . . . .	4-30, 5-18, 5-19, 7-15, 8-08, 8-13
Interagency Water Control Management Agreements . . . . .	7-06
Interior Areas . . . . .	1-07, 4-25
Interior Drainage Facilities . . . . .	1-03, 3-08, 4-01, 7-11
Interior Flood Control . . . . .	4-24, 4-25
International Boards . . . . .	8-09
Iron . . . . .	2-21, 2-29
Irrigation . . . . .	1-04, 2-01 - 2-03, 2-13, 2-14, 2-16 - 2-18, 3-04, 3-05, 3-17, 3-18, 3-20, 4-06, 4-13, 4-22, 4-23, 5-09, 6-10, 6-13, 8-06, 8-07, 8-12, 8-14
Limited Automatic Remote Collector (LARC) . . . . .	5-14
Large Screen Display . . . . .	5-15, 8-05
Levees . . . . .	2-05, 2-07 - 2-10, 7-11, 9-14
Line-of-Protection . . . . .	4-24
Line-of-Sight . . . . .	5-10
Load Factor . . . . .	4-31
Local Protection Projects . . . . .	2-09
Lockages . . . . .	2-13, 5-05
Loss of Commercial Power . . . . .	5-16
Low-Flow Analysis . . . . .	3-05
Low-Flow Conditions . . . . .	3-20, 6-09
Lower Mississippi Valley Division (LMVD) . . . . .	5-10
M&I . . . . .	2-18, 2-19, 3-04, 3-18, 3-20, 4-23
Manganese . . . . .	2-21
Master Manual . . . . .	9-05, 9-06, 9-18
Master Plan for Water Control Data Systems . . . . .	5-19
Master Water Control Manual . . . . .	2-03, 9-06, 9-15, 9-18
Media . . . . .	1-05, 5-09, 5-10, 8-04, 8-14, 8-17
Memorandum of Understanding (MOU) . . . . .	5-19, 8-10, 8-11, 9-17
Meteor-Burst Communication System . . . . .	5-13
Microwave Communication Systems . . . . .	5-09, 5-14
Minimum Streamflows . . . . .	2-03, 2-34
Morning Report . . . . .	9-17
Multilevel Withdrawal . . . . .	2-21
National Aeronautics and Space Administration (NASA) . . . . .	5-18
National Earth Satellite, Dissemination and Information Service (NESDIS) . . . . .	5-11

30 Nov 87

National Oceanic and Atmospheric Administration	
(NOAA)	5-11, 5-18
National Weather Service (NWS)	3-25, 5-04, 5-05, 5-08, 5-13, 5-18, 6-05 - 6-07, 7-02, 7-14, 7-15, 8-07, 8-11, 8-17, 8-18 - 8-20, 9-16
Natural Disaster	1-05, 8-16, 9-03, 9-09
Navigation	1-02 - 1-04, 1-06, 1-07, 2-01 - 2-05, 2-09, 2-11 - 2-14, 2-17, 2-18, 2-29, 2-30, 3-01, 3-02, 3-04, 3-05, 3-08, 3-15, 3-17, 3-18, 3-20, 3-21, 4-01, 4-04, 4-06, 4-12, 4-22 - 4-24, 4-31, 5-05, 5-09, 6-10, 6-17, 7-01, 7-06, 7-09, 8-06, 8-07, 8-10, 8-12, 8-14, 8-18, 8-20, 9-09, 9-16
Nesting	2-29
New England Division (NED)	5-10, 8-01
Non-Corps Projects	1-03, 1-06, 7-06, 7-09, 7-11, 8-10, 8-16, 8-19
Non-Federal Hydropower	2-15, 5-19, 8-08, 8-11
North Pacific Division (NPD)	7-15
Operating Committees	8-09, 8-12, 8-13
Operating Reserves	4-31
Operation and Maintenance (O&M)	1-01, 2-09, 2-11, 4-25, 4-27, 8-02, 8-03, 8-08, 8-18, 8-20, 9-01 - 9-03, 9-07, 9-09, 9-12
Operations Division	2-08, 4-27, 8-02, 8-18, 8-19, 9-01, 9-02
Operators Reports	8-15
Organization	1-05, 3-02, 8-01, 8-08
Outages	2-15, 4-30 - 4-32, 5-13, 5-14, 6-12, 9-14
Outlet Works	1-07, 2-02, 2-19, 2-31, 2-33, 3-08, 4-01 - 4-03, 4-06, 4-08, 4-10 - 4-13, 4-22, 4-23, 4-33, 6-04, 9-09
Oxidation	2-21
Peaking Operation	4-31
Penstock	4-26
Periodic Inspections	8-21
Public Law (PL)	2-01, 2-29
Planning and Design Studies	1-03, 3-04, 3-06, 3-08, 3-09, 3-17, 6-01
Planning Guidance	1-05
Pondage	4-26, 4-31
Power Marketing Agency	4-28, 4-29
Probable Maximum Flood	4-11
Project Type	9-18
Proponent Sponsored Engineer Corps Training Program (PROSPECT)	8-03
Protocol	5-13
Public Hearings	8-14, 8-15
Pumping Stations	2-11, 4-25

Random Reporting System . . . . .	5-11
Recession Constant . . . . .	4-17, 4-18
Recreation . . . . .	1-03, 2-02, 2-03, 2-12, 2-14, 2-29, 2-30, 2-32, 3-17, 3-21, 3-25, 6-10, 6-13, 8-06, 8-07, 8-12, 8-15, 8-20, 9-16
Regulation Schedules . . . . .	1-02, 2-02, 2-07, 3-06, 3-08, 3-10, 3-13, 3-14, 3-17, 3-19, 3-22, 3-23, 4-06, 4-10, 4-11, 4-17, 4-24, 4-29, 6-02, 6-12, 7-01, 7-03, 7-08, 7-09, 7-12, 8-12, 8-14
Reserve Capacity . . . . .	4-27, 4-31
Reservoir Control Center . . . . .	8-06
Reservoir Deposition . . . . .	2-32
Reservoir Fisheries . . . . .	2-23, 2-24
Reservoir Regulation Schedules . . . . .	4-06, 4-10, 4-29, 7-12
Reservoir System Analysis . . . . .	3-17, 3-24, 6-02 - 6-04, 6-12, 6-13
Revegetation . . . . .	2-25, 2-29
Ring-Follower Gates . . . . .	4-07
Run-of-River Projects . . . . .	2-14
Seasonal Flood Control . . . . .	3-15, 3-16, 3-18
Seasonal Storage . . . . .	3-17, 4-13
Section 7 Projects . . . . .	8-20
Sedimentation . . . . .	6-16, 6-17, 8-04
Seepage . . . . .	2-09
Selective Withdrawal Facilities . . . . .	2-21, 2-22, 4-01
Shoreline Erosion . . . . .	2-24, 2-31, 2-32
Shoreline Vegetation . . . . .	2-24, 2-25
Simulation Models . . . . .	3-13, 3-14, 4-14, 6-08, 6-09, 6-11, 6-12
Sluice Gates . . . . .	1-01
Sluices . . . . .	2-10, 4-01, 4-07, 4-08, 4-10, 4-24
Snowmelt . . . . .	1-07, 2-06, 3-13 - 3-15, 6-01, 6-04, 6-06, 6-10, 6-11, 7-04, 7-10
Social Values . . . . .	2-06
Soil Conservation Service . . . . .	5-13, 5-18, 7-03
Spawning . . . . .	2-24 - 2-26, 2-28, 4-33
Special Advisories . . . . .	8-16
Spillway Gate Operation . . . . .	4-02, 4-06, 4-14
Spillway Gate Regulation Schedule . . . . .	4-17, 4-19
Spillway Gates . . . . .	1-01, 1-03, 4-03 - 4-06, 4-12 - 4-14, 4-17, 4-19, 4-22, 6-17, 6-19, 9-09
Spillways . . . . .	1-03, 1-07, 2-10, 2-28, 3-08, 4-01 - 4-03, 4-05, 4-06, 4-10 - 4-14, 4-17, 4-33, 4-34, 4-36, 6-17
Spinning Reserve . . . . .	4-27, 4-31, 4-32
Sport Fishes . . . . .	2-26
Staffing . . . . .	1-05, 3-02, 4-26, 7-08, 8-02
Standard Hydrometeorological Exchange Format (SHEF) . . . . .	5-20
Standard Project Flood . . . . .	2-06, 2-08



Standing Instructions . . . . .	2-09, 8-02, 8-15, 8-17, 8-20, 9-01 - 9-04, 9-09, 9-11, 9-12, 9-16 - 9-18
Static Pool . . . . .	6-18
Statistical Analysis . . . . .	6-10
Statistical Procedures . . . . .	6-10, 6-11
Stilling Basin . . . . .	4-03, 4-04, 4-10, 4-12, 4-36
Storm Surge . . . . .	1-07, 6-06, 6-07
Storm Tides . . . . .	6-18, 6-19
Surcharge Storage . . . . .	1-03, 4-02, 4-11, 4-13, 4-14, 4-17, 4-19, 4-22
Tailrace . . . . .	4-26
Tailwater Fisheries . . . . .	2-26
Tainter Gates . . . . .	4-05, 4-08
Temperature Stratification . . . . .	2-21, 2-27, 5-05
Tennessee Valley Authority (TVA) . . . . .	2-05, 5-13, 5-18
Tidal Barriers . . . . .	2-10, 3-08, 4-01, 4-24
Tidal Hydraulics . . . . .	1-05
Training . . . . .	8-03
Transformers . . . . .	4-25, 4-26
Turbines . . . . .	2-28, 4-01, 4-23, 4-26, 4-33, 4-34
Type of Project . . . . .	2-02, 5-18
Uncontrolled Outlet Works . . . . .	2-02
Vertical Lift Gates . . . . .	4-05, 4-07 - 4-09
VHF Radio . . . . .	5-09, 5-10, 5-13
Vibration . . . . .	4-02, 4-05, 4-07 - 4-09
Water Balance . . . . .	6-10, 6-11, 6-18
Water Control Center (WCC) . . . . .	2-08, 4-27, 7-08, 7-09, 8-01, 8-04, 8-07, 8-10, 8-12, 8-15, 9-10
Water Control Data System (WCDS) . . . . .	5-01, 5-02, 5-09, 5-16, 7-02, 8-05, 8-18, 8-19
Water Control Database . . . . .	5-01, 5-15
Water Control Diagrams . . . . .	1-03, 2-07, 2-30, 3-06, 3-14 - 3-20, 3-23, 9-14
Water Control Documents . . . . .	1-05, 2-02, 8-17, 8-18, 9-01, 9-09, 9-10
Water Control Manual . . . . .	2-03, 3-08, 4-30, 7-01, 7-12, 9-02, 9-04 - 9-06, 9-15, 9-18
Water Control Plan . . . . .	1-04, 2-01 - 2-03, 2-06, 2-11, 2-13, 2-30, 3-02 - 3-04, 3-06, 3-08, 3-09, 3-17, 3-19, 3-21, 3-22, 4-29, 4-34, 5-02, 6-02, 6-12, 7-02, 7-04, 8-11, 8-12, 9-02, 9-03 - 9-06, 9-08, 9-10, 9-11, 9-16, 9-18
Water Duty . . . . .	2-17
Water Level Management . . . . .	2-25, 2-27

Water Management Activities . . .	1-02, 1-05, 3-01, 3-02, 6-03, 6-05, 6-07, 6-16, 6-17, 6-19, 7-02, 7-03, 7-09, 7-15, 8-01, 8-04, 8-08 - 8-10, 8-12 - 8-14
Water Management Goals . . .	2-01, 2-03, 3-01, 3-02, 3-09, 3-22, 4-01, 4-08, 4-27 - 4-29, 6-13, 7-01, 7-06, 8-13, 8-15
Water Management Plan . . . . .	3-04
Water Plants . . . . .	2-25
Water Quality Control . . . . .	1-06, 2-20 - 2-22, 3-03, 3-23, 4-10, 4-34, 6-04
Water Quality Data . . .	1-06, 2-20, 3-03, 3-24, 5-03, 5-05, 8-08
Water Quality Forecasts . . . . .	6-15
Water Quality Management Activities . . . . .	2-20, 8-20
Water Quality Objectives . . . . .	3-24
Water Quality Releases . . . . .	2-21
Water Quality Standards . . . . .	2-20, 2-21
Water Supply Use . . . . .	2-02, 2-14, 2-18
Water Use Organizations . . . . .	8-11
Water Utilization . . . . .	3-20, 8-14
Waterfowl Management . . . . .	2-25
Waterways Experiment Station (WES) . . . . .	8-04
WATSTORE . . . . .	8-19
Weather Forecasts . . .	3-16, 6-05 - 6-09, 7-02, 7-12, 7-14, 8-05, 8-07
Weirs . . . . .	4-10, 4-35, 9-01
Wildlife Habitat . . . . .	2-28, 2-29, 7-01
Wildlife Management . . . . .	2-23, 2-24, 2-29
Wind Setup . . . . .	6-18
Winter Navigation . . . . .	2-13, 3-21